

# Service Manual

## Air Conditioner

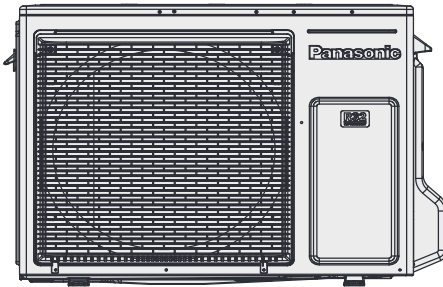
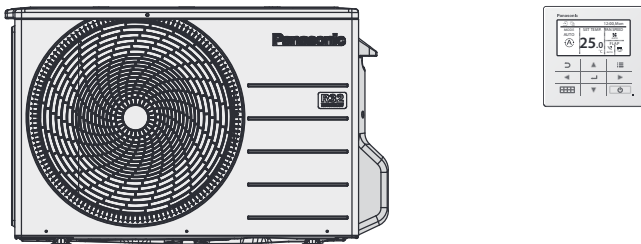

**Indoor Unit**  
**CS-Z25YKEA**  
**CS-Z35YKEA**  
**CS-Z42YKEA**  
**CS-Z50YKEA**  
**CS-Z71YKEA**

**Outdoor Unit**  
**CU-Z25YKEA**  
**CU-Z35YKEA**  
**CU-Z42YKEA**  
**CU-Z50YKEA**  
**CU-Z71YKEA**

**Destination**  
**Europe**  
**Turkey**

Please file and use this manual together with Wireless LAN Module Setup Instructions Order No. ACXF55-33580

### **WARNING**

This service information is designed for experienced repair technicians only and is not designed for use by the general public. It does not contain warnings or cautions to advise non-technical individuals of potential dangers in attempting to service a product. Products powered by electricity should be serviced or repaired only by experienced professional technicians. Any attempt to service or repair the products dealt with in this service information by anyone else could result in serious injury or death.

### **IMPORTANT SAFETY NOTICE**

There are special components used in this equipment which are important for safety. These parts are marked by  in the Schematic Diagrams, Circuit Board Diagrams, Exploded Views and Replacement Parts List. It is essential that these critical parts should be replaced with manufacturer's specified parts to prevent shock, fire or other hazards. Do not modify the original design without permission of manufacturer.

### **PRECAUTION OF LOW TEMPERATURE**

In order to avoid frostbite, be assured of no refrigerant leakage during the installation or repairing of refrigerant circuit.

### **CAUTION**

**R32 REFRIGERANT** – This Air Conditioner contains and operates with refrigerant R32.  
**THIS PRODUCT MUST ONLY BE INSTALLED OR SERVICED BY QUALIFIED PERSONNEL.**



Refer to National, State, Territory and local legislation, regulations, codes, installation & operation manuals, before the installation, maintenance and/or service of this product.

# TABLE OF CONTENTS



	PAGE		PAGE
<b>1. Safety Precautions</b> .....	<b>3</b>	14.6 Quiet Operation (Heating) .....	92
<b>2. Precaution for Using R32 Refrigerant</b> .....	<b>5</b>	14.7 Powerful Operation .....	92
<b>3. Specifications</b> .....	<b>10</b>	14.8 Weekly Timer .....	93
<b>4. Features</b> .....	<b>25</b>	14.9 Auto Restart Control .....	93
<b>5. Location of Controls and Components</b> .....	<b>26</b>	14.10 Indication Panel .....	94
5.1 Indoor Unit .....	26	14.11 WLAN Control .....	94
5.2 Outdoor Unit .....	26	14.12 Duty Rotation Control (Optional) .....	98
5.3 Remote Control .....	27	14.13 Duty Rotation Setup .....	105
<b>6. Dimensions</b> .....	<b>37</b>	<b>15. Protection Control</b> .....	<b>112</b>
6.1 Indoor Unit .....	37	15.1 Protection Control for All Operations .....	112
6.2 Outdoor Unit .....	39	15.2 Protection Control for Cooling & Soft Dry Operation .....	114
<b>7. Refrigeration Cycle Diagram</b> .....	<b>40</b>	15.3 Protection Control for Heating Operation .....	115
7.1 CS-Z25YKEA CU-Z25YKEA CS-Z35YKEA CU-Z35YKEA CS-Z42YKEA CU-Z42YKEA .....	40	<b>16. Servicing Mode</b> .....	<b>117</b>
7.2 CS-Z50YKEA CU-Z50YKEA .....	41	16.1 Auto OFF/ON Button .....	117
7.3 CS-Z71YKEA CU-Z71YKEA .....	42	<b>17. Troubleshooting Guide</b> .....	<b>118</b>
<b>8. Block Diagram</b> .....	<b>43</b>	17.1 Refrigeration Cycle System .....	118
<b>9. Wiring Connection Diagram</b> .....	<b>44</b>	17.2 Breakdown Self Diagnosis Function .....	120
9.1 Indoor Unit .....	44	17.3 Error Codes Table .....	123
9.2 Outdoor Unit .....	45	17.4 Self-diagnosis Method .....	125
<b>10. Electronic Circuit Diagram</b> .....	<b>47</b>	<b>18. Disassembly and Assembly Instructions</b> ...	<b>155</b>
10.1 Indoor Unit .....	47	18.1 CS-Z25YKEA CS-Z35YKEA CS-Z42YKEA .....	155
10.2 Outdoor Unit .....	48	18.2 CS-Z50YKEA CS-Z71YKEA .....	162
<b>11. Printed Circuit Board</b> .....	<b>50</b>	18.3 To setup Wireless LAN Module and Panasonic Comfort Cloud .....	168
11.1 Indoor Unit .....	50	18.4 Outdoor Electronic Controller Removal Procedure .....	169
11.2 Outdoor Unit .....	52	<b>19. Technical Data</b> .....	<b>171</b>
<b>12. Installation Instruction</b> .....	<b>53</b>	19.1 Cool Mode Performance Data .....	171
12.1 Select the Best Location .....	53	19.2 Heat Mode Performance Data .....	174
12.2 Indoor Unit .....	54	<b>20. Service Data</b> .....	<b>175</b>
12.3 Outdoor Unit .....	60	20.1 Cool Mode Outdoor Air Temperature Characteristic .....	175
<b>13. Installation and Servicing Air Conditioner using R32</b> .....	<b>66</b>	20.2 Heat Mode Outdoor Air Temperature Characteristic .....	180
13.1 About R32 Refrigerant .....	66	20.3 Piping Length Correction Factor .....	185
13.2 Characteristics of R32 Refrigerant .....	66	<b>21. Exploded View and Replacement Parts List</b> .....	<b>187</b>
13.3 Refrigerant piping installation • Tools used in services .....	68	21.1 Indoor Unit .....	187
13.4 New installation, Relocation, Repairing of Refrigerant Cycle System The Procedures .....	72	21.2 Outdoor Unit .....	193
13.5 Piping installation of R32 .....	73		
13.6 Installation, Relocation, and Service .....	74		
13.7 Repairing of refrigerant cycle / Brazing point .....	78		
13.8 <Reference> Analysis method for no error code, no cooling / no warming .....	84		
<b>14. Operation Control</b> .....	<b>86</b>		
14.1 Basic Function .....	86		
14.2 Indoor Fan Motor Operation .....	87		
14.3 Outdoor Fan Motor Operation .....	88		
14.4 Airflow Direction .....	89		
14.5 Quiet Operation (Cooling) .....	92		

# 1. Safety Precautions















- Read the following “SAFETY PRECAUTIONS” carefully before installation.
- Electrical work must be installed by a licensed electrician. Be sure to use the correct rating of the power plug and main circuit for the model to be installed.
- The caution items stated here must be followed because these important contents are related to safety. The meaning of each indication used is as below.
- Incorrect installation due to ignoring of the instruction will cause harm or damage, and the seriousness is classified by the following indications.

 <b>WARNING</b>	This indication shows the possibility of causing death or serious injury.
 <b>CAUTION</b>	This indication shows the possibility of causing injury or damage to properties.

- The items to be followed are classified by the symbols:

	Symbol with white background denotes item that is PROHIBITED.
 	Symbol with dark background denotes item that must be carried out.







- Carry out test running to confirm that no abnormality occurs after the installation. Then, explain to user the operation, care and maintenance as stated in instructions. Please remind the customer to keep the operating instructions for future reference.

 <b>WARNING</b>	
1.	Do not use means to accelerate the defrosting process or to clean, other than those recommended by the manufacturer. Any unfit method or using incompatible material may cause product damage, burst and serious injury. 
2.	Do not install outdoor unit near handrail of veranda. When installing air-conditioner unit on veranda of a high rise building, child may climb up to outdoor unit and cross over the handrail causing an accident. 
3.	Do not use unspecified cord, modified cord, joint cord or extension cord for power supply cord. Do not share the single outlet with other electrical appliances. Poor contact, poor insulation or over current will cause electrical shock or fire. 
4.	Do not tie up the power supply cord into a bundle by band. Abnormal temperature rise on power supply cord may happen. 
5.	Do not insert your fingers or other objects into the unit, high speed rotating fan may cause injury.  
6.	Do not sit or step on the unit, you may fall down accidentally.  
7.	Keep plastic bag (packaging material) away from small children, it may cling to nose and mouth and prevent breathing.   
8.	When installing or relocating air conditioner, do not let any substance other than the specified refrigerant, eg. air etc mix into refrigeration cycle (piping). Mixing of air etc. will cause abnormal high pressure in refrigeration cycle and result in explosion, injury etc. 
9.	Do not pierce or burn as the appliance is pressurized. Do not expose the appliance to heat, flame, sparks, or other sources of ignition. Else, it may explode and cause injury or death. 
10.	Do not add or replace refrigerant other than specified type. It may cause product damage, burst and injury etc. 
11.	<ul style="list-style-type: none"> <li>• For R32/R410A model, use piping, flare nut and tools which is specified for R32/R410A refrigerant. Using of existing (R22) piping, flare nut and tools may cause abnormally high pressure in the refrigerant cycle (piping), and possibly result in explosion and injury. For R32 and R410A, the same flare nut on the outdoor unit side and pipe can be used.</li> <li>• Since the working pressure for R32/R410A is higher than that of refrigerant R22 model, replacing conventional piping and flare nuts on the outdoor unit side are recommended.</li> <li>• If reuse piping is unavoidable, refer to instruction “IN CASE OF REUSING EXISTING REFRIGERANT PIPING”</li> <li>• Thickness for copper pipes used with R32/R410A must be more than 0.8 mm. Never use copper pipes thinner than 0.8 mm.</li> <li>• It is desirable that the amount of residual oil less than 40 mg/10 m.</li> </ul>
12.	Engage authorized dealer or specialist for installation. If installation done by the user is incorrect, it will cause water leakage, electrical shock or fire.
13.	For refrigeration system work, install according to this installation instructions strictly. If installation is defective, it will cause water leakage, electrical shock or fire.
14.	Use the attached accessories parts and specified parts for installation. Otherwise, it will cause the set to fall, water leakage, fire or electrical shock.
15.	Install at a strong and firm location which is able to withstand weight of the set. If the strength is not enough or installation is not properly done, the set will drop and cause injury.
16.	For electrical work, follow the national regulation, legislation and this installation instructions. An independent circuit and single outlet must be used. If electrical circuit capacity is not enough or defect found in the electrical work, it will cause electrical shock or fire.

 **WARNING**

17.	Do not use joint cable for indoor / outdoor connection cable. Use the specified indoor/outdoor connection cable, refer to instruction <b>CONNECT THE CABLE TO THE INDOOR UNIT</b> and connect tightly for indoor/outdoor connection. Clamp the cable so that no external force will have impact on the terminal. If connection or fixing is not perfect, it will cause heat up or fire at the connection.
18.	Wire routing must be properly arranged so that control board cover is fixed properly. If control board cover is not fixed perfectly, it will cause fire or electrical shock.
19.	This equipment is strongly recommended to be installed with Earth Leakage Circuit Breaker (ELCB) or Residual Current Device (RCD), with sensitivity of 30mA at 0.1 sec or less. Otherwise, it may cause electrical shock and fire in case of equipment breakdown or insulation breakdown.
20.	During installation, install the refrigerant piping properly before running the compressor. Operation of compressor without fixing refrigeration piping and valves at opened position will cause suck-in of air, abnormal high pressure in refrigeration cycle and result in explosion, injury etc.
21.	During pump down operation, stop the compressor before removing the refrigeration piping. Removal of refrigeration piping while compressor is operating and valves are opened will cause suck-in of air, abnormal high pressure in refrigeration cycle and result in explosion, injury etc.
22.	Tighten the flare nut with torque wrench according to specified method. If the flare nut is over-tightened, after a long period, the flare may break and cause refrigerant gas leakage.
23.	After completion of installation, confirm there is no leakage of refrigerant gas. It may generate toxic gas when the refrigerant contacts with fire.
24.	Ventilate if there is refrigerant gas leakage during operation. It may cause toxic gas when the refrigerant contacts with fire.
25.	Be aware that refrigerants may not contain an odour.
26.	This equipment must be properly earthed. Earth line must not be connected to gas pipe, water pipe, earth of lightning rod and telephone. Otherwise, it may cause electrical shock in case of equipment breakdown or insulation breakdown.
27.	Do not modify the machine, part, material during repairing service.
28.	If wiring unit is supplied as repairing part, do not repair or connect the wire even only partial wire break. Exchange the whole wiring unit.
29.	Do not wrench the fasten terminal. Pull it out or insert it straightly.
30.	Must not use other parts except original parts describe in catalog and manual.

 **CAUTION**

1.	Do not install the unit in a place where leakage of flammable gas may occur. In case gas leaks and accumulates at surrounding of the unit, it may cause fire. 
2.	Prevent liquid or vapor from entering sumps or sewers since vapor is heavier than air and may form suffocating atmospheres. 
3.	Do not release refrigerant during piping work for installation, re-installation and during repairing refrigeration parts. Take care of the liquid refrigerant, it may cause frostbite. 
4.	Do not install this appliance in a laundry room or other location where water may drip from the ceiling, etc. 
5.	Do not touch the sharp aluminium fin, sharp parts may cause injury.  
6.	Carry out drainage piping as mentioned in installation instructions. If drainage is not perfect, water may enter the room and damage the furniture.
7.	Select an installation location which is easy for maintenance. Incorrect installation, service or repair of this air conditioner may increase the risk of rupture and this may result in loss damage or injury and/or property.
8.	Power supply connection to the room air conditioner. Use power supply cord 3 x 1.5 mm <sup>2</sup> (1.0 ~ 1.75HP), 3 x 2.5 mm <sup>2</sup> (2.0 ~ 2.5HP) type designation 60245 IEC 57 or heavier cord. Connect the power supply cord of the air conditioner to the mains using one of the following method. Power supply point should be in easily accessible place for power disconnection in case of emergency. In some countries, permanent connection of this air conditioner to the power supply is prohibited. 1) Power supply connection to the receptacle using power plug. Use an approved 15/16 A (1.0 ~ 1.75HP) or 16 A (2.0HP) or 20 A (2.5HP), power plug with earth pin for the connection to the socket. 2) Power supply connection to a circuit breaker for the permanent connection. Use an approved 16 A (1.0 ~ 2.0HP) or 20 A (2.5HP) circuit breaker for the permanent connection. It must be a double pole switch with a minimum 3.0 mm contact gap.
9.	Installation work. It may need two people to carry out the installation work.
10.	Keep any required ventilation openings clear of obstruction.
11.	Pb free solder has a higher melting point than standard solder; typically the melting point is 50°F – 70°F (30°C – 40°C) higher. Please use a high temperature solder iron. In case of the soldering iron with temperature control, please set it to 700 ± 20°F (370 ± 10°C). Pb free solder will tend to splash when heated too high (about 1100°F / 600°C).

## 2. Precaution for Using R32 Refrigerant

- Pay careful attention to the following precaution points and the installation work procedures.

 <b>WARNING</b>	
1.	When connecting flare at indoor side, make sure that the flare connection is used only once, if torqued up and released, the flare must be remade. Once the flare connection was torqued up correctly and leak test was made, thoroughly clean and dry the surface to remove oil, dirt and grease by following instructions of silicone sealant. Apply neutral cure (Alkoxy type) & ammonia-free silicone sealant that is non-corrosive to copper & brass to the external of the flared connection to prevent the ingress of moisture on both the gas & liquid sides. (Moisture may cause freezing and premature failure of the connection).
2.	The appliance shall be stored, installed and operated in a well ventilated room with indoor floor area larger than $A_{min}$ (m <sup>2</sup> ) [refer Table A] and without any continuously operating ignition source. Keep away from open flames, any operating gas appliances or any operating electric heater. Else, it may explode and cause injury or death.
3.	The mixing of different refrigerants within a system is prohibited. Models that use refrigerant R32 and R410A have a different charging port thread diameter to prevent erroneous charging with refrigerant R22 and for safety. Therefore, check beforehand. [The charging port thread diameter for R32 and R410A is 12.7 mm (1/2 inch).]
4.	Ensure that foreign matter (oil, water, etc.) does not enter the piping. Also, when storing the piping, securely seal the opening by pinching, taping, etc. (Handling of R32 is similar to R410A.)
5.	Operation, maintenance, repairing and refrigerant recovery should be carried out by trained and certified personnel in the use of flammable refrigerants and as recommended by the manufacturer. Any personnel conducting an operation, servicing or maintenance on a system or associated parts of the equipment should be trained and certified.
6.	Any part of refrigerating circuit (evaporators, air coolers, AHU, condensers or liquid receivers) or piping should not be located in the proximity of heat sources, open flames, operating gas appliance or an operating electric heater.
7.	The user/owner or their authorized representative shall regularly check the alarms, mechanical ventilation and detectors, at least once a year, where as required by national regulations, to ensure their correct functioning.
8.	A logbook shall be maintained. The results of these checks shall be recorded in the logbook.
9.	In case of ventilations in occupied spaces shall be checked to confirm no obstruction.
10.	Before a new refrigerating system is put into service, the person responsible for placing the system in operation should ensure that trained and certified operating personnel are instructed on the basis of the instruction manual about the construction, supervision, operation and maintenance of the refrigerating system, as well as the safety measures to be observed, and the properties and handling of the refrigerant used.
11.	The general requirement of trained and certified personnel are indicated as below: a) Knowledge of legislation, regulations and standards relating to flammable refrigerants; and, b) Detailed knowledge of and skills in handling flammable refrigerants, personal protective equipment, refrigerant leakage prevention, handling of cylinders, charging, leak detection, recovery and disposal; and, c) Able to understand and to apply in practice the requirements in the national legislation, regulations and Standards; and, d) Continuously undergo regular and further training to maintain this expertise.
12.	Air-conditioner piping in the occupied space shall be installed in such a way to protect against accidental damage in operation and service.
13.	Precautions shall be taken to avoid excessive vibration or pulsation to refrigerating piping.
14.	Ensure protection devices, refrigerating piping and fittings are well protected against adverse environmental effects (such as the danger of water collecting and freezing in relief pipes or the accumulation of dirt and debris).
15.	Expansion and contraction of long runs piping in refrigerating systems shall be designed and installed securely (mounted and guarded) to minimize the likelihood hydraulic shock damaging the system.
16.	Protect the refrigerating system from accidental rupture due to moving furniture or reconstruction activities.
17.	To ensure no leaking, field-made refrigerant joints indoors shall be tightness tested. The test method shall have a sensitivity of 5 grams per year of refrigerant or better under a pressure of at least 0,25 times the maximum allowable pressure (>1.04MPa, max 4.15MPa). No leak shall be detected.

 CAUTION

General

1.
  - Must ensure the installation of pipe-work shall be kept to a minimum. Avoid use dented pipe and do not allow acute bending.
  - Must ensure that pipe-work shall be protected from physical damage.
  - Must comply with national gas regulations, state municipal rules and legislation. Notify relevant authorities in accordance with all applicable regulations.
  - Must ensure mechanical connections be accessible for maintenance purposes.
  - In cases that require mechanical ventilation, ventilation openings shall be kept clear of obstruction.
  - When disposal of the product, do follow to the precautions in #11 and comply with national regulations.
  - In case of field charge, the effect on refrigerant charge caused by the different pipe length has to be quantified, measured and labelled.
  - Always contact to local municipal offices for proper handling.
  - Ensure the actual refrigerant charge is in accordance with the room size within which the refrigerant containing parts are installed.
  - Ensure refrigerant charge not to leak.
  - Wear appropriate protective equipment, including respiratory protection, as conditions warrant.
  - Keep all sources of ignition and hot metal surfaces away.

Servicing

2.
  - 2-1. Qualification of workers
    - Any qualified person who is involved with working on or breaking into a refrigerant circuit should hold a current valid certificate from an industry-accredited assessment authority, which authorizes their competence to handle refrigerants safely in accordance with an industry recognized assessment specification.
    - Servicing shall only be performed as recommended by the equipment manufacturer. Maintenance and repair requiring the assistance of other skilled personnel shall be carried out under the supervision of the person competent in the use of flammable refrigerants.
    - Servicing shall be performed only as recommended by the manufacturer.
    - The system is inspected, regularly supervised and maintained by a trained and certified service personnel who is employed by the person user or party responsible.
  - 2-2. Checks to the area
    - Prior to beginning work on systems containing flammable refrigerants, safety checks are necessary to ensure that the risk of ignition is minimised.
    - For repair to the refrigerating system, the precautions in #2-3 to #2-7 must be followed before conducting work on the system.
  - 2-3. Work procedure
    - Work shall be undertaken under a controlled procedure so as to minimize the risk of a flammable gas or vapour being present while the work is being performed.
  - 2-4. General work area
    - All maintenance staff and others working in the local area shall be instructed and supervised on the nature of work being carried out.
    - Avoid working in confined spaces. Always ensure away from source, at least 2 meter of safety distance, or zoning of free space area of at least 2 meter in radius.
  - 2-5. Checking for presence of refrigerant
    - The area shall be checked with an appropriate refrigerant detector prior to and during work, to ensure the technician is aware of potentially flammable atmospheres.
    - Ensure that the leak detection equipment being used is suitable for use with flammable refrigerants, i.e. non sparking, adequately sealed or intrinsically safe.
    - In case of leakage/spillage happened, immediately ventilate area and stay upwind and away from spill/release.
  - 2-6. Presence of fire extinguisher
    - If any hot work is to be conducted on the refrigerating equipment or any associated parts, appropriate fire extinguishing equipment shall be available at hand.
    - Have a dry powder or CO<sub>2</sub> fire extinguisher adjacent to the charging area.
  - 2-7. No ignition sources
    - No person carrying out work in relation to a refrigerating system which involves exposing any pipe work that contains or has contained flammable refrigerant shall use any sources of ignition in such a manner that it may lead to the risk of fire or explosion. He/She must not be smoking when carrying out such work.
    - All possible ignition sources, including cigarette smoking, should be kept sufficiently far away from the site of installation, repairing, removing and disposal, during which flammable refrigerant can possibly be released to the surrounding space.
    - Prior to work taking place, the area around the equipment is to be surveyed to make sure that there are no flammable hazards or ignition risks.
    - "No Smoking" signs shall be displayed.
  - 2-8. Ventilated area
    - Ensure that the area is in the open or that it is adequately ventilated before breaking into the system or conducting any hot work.
    - A degree of ventilation shall continue during the period that the work is carried out.
    - The ventilation should safely disperse any released refrigerant and preferably expel it externally into the atmosphere.
  - 2-9. Checks to the refrigerating equipment
    - Where electrical components are being changed, they shall be fit for the purpose and to the correct specification.
    - At all times the manufacturer's maintenance and service guidelines shall be followed.
    - If in doubt consult the manufacturer's technical department for assistance.
    - The following checks shall be applied to installations using flammable refrigerants.
      - The actual refrigerant charge is in accordance with the room size within which the refrigerant containing parts are installed.
      - The ventilation machinery and outlets are operating adequately and are not obstructed.
      - If an indirect refrigerating circuit is being used, the secondary circuit shall be checked for the presence of refrigerant.
      - Marking to the equipment continues to be visible and legible. Markings and signs that are illegible shall be corrected.
      - Refrigerating pipe or components are installed in a position where they are unlikely to be exposed to any substance which may corrode refrigerant containing components, unless the components are constructed of materials which are inherently resistant to being corroded or are properly protected against being so corroded.

**CAUTION****2-10. Checks to electrical devices**

- Repair and maintenance to electrical components shall include initial safety checks and component inspection procedures.
  - Initial safety checks shall include but not limit to:-
    - That capacitors are discharged: this shall be done in a safe manner to avoid possibility of sparking.
    - That there is no live electrical components and wiring are exposed while charging, recovering or purging the system.
    - That there is continuity of earth bonding.
- 2.
- At all times the manufacturer's maintenance and service guidelines shall be followed.
  - If in doubt consult the manufacturer's technical department for assistance.
  - If a fault exists that could compromise safety, then no electrical supply shall be connected to the circuit until it is satisfactorily dealt with.
  - If the fault cannot be corrected immediately but it is necessary to continue operation, an adequate temporary solution shall be used.
  - The owner of the equipment must be informed or reported so all parties are advised thereafter.

**Repairs to sealed components**

- During repairs to sealed components, all electrical supplies shall be disconnected from the equipment being worked upon prior to any removal of sealed covers, etc.
  - If it is absolutely necessary to have an electrical supply to equipment during servicing, then a permanently operating form of leak detection shall be located at the most critical point to warn of a potentially hazardous situation.
  - Particular attention shall be paid to the following to ensure that by working on electrical components, the casing is not altered in such a way that the level of protection is affected. This shall include damage to cables, excessive number of connections, terminals not made to original specification, damage to seals, incorrect fitting of glands, etc.
- 3.
- Ensure that apparatus is mounted securely.
  - Ensure that seals or sealing materials have not degraded such that they no longer serve the purpose of preventing the ingress of flammable atmospheres.
  - Replacement parts shall be in accordance with the manufacturer's specifications.

<b>NOTE:</b> The use of silicon sealant may inhibit the effectiveness of some types of leak detection equipment. Intrinsically safe components do not have to be isolated prior to working on them.
---

**Repair to intrinsically safe components**

- Do not apply any permanent inductive or capacitance loads to the circuit without ensuring that this will not exceed the permissible voltage and current permitted for the equipment in use.
- 4.
- Intrinsically safe components are the only types that can be worked on while live in the presence of a flammable atmosphere.
  - The test apparatus shall be at the correct rating.
  - Replace components only with parts specified by the manufacturer. Unspecified parts by manufacturer may result ignition of refrigerant in the atmosphere from a leak.

**Cabling**

- 5.
- Check that cabling will not be subject to wear, corrosion, excessive pressure, vibration, sharp edges or any other adverse environmental effects.
  - The check shall also take into account the effects of aging or continual vibration from sources such as compressors or fans.

**Detection of flammable refrigerants**

- Under no circumstances shall potential sources of ignition be used in the searching or detection of refrigerant leaks.
  - A halide torch (or any other detector using a naked flame) shall not be used.
  - The following leak detection methods are deemed acceptable for all refrigerant systems.
    - No leaks shall be detected when using detection equipment with a sensitivity of 5 grams per year of refrigerant or better under a pressure of at least 0,25 times the maximum allowable pressure (>1.04MPa, max 4.15MPa) for example, a universal sniffer.
    - Electronic leak detectors may be used to detect flammable refrigerants, but the sensitivity may not be adequate, or may need re-calibration.  
(Detection equipment shall be calibrated in a refrigerant-free area.)
- 6.
- Ensure that the detector is not a potential source of ignition and is suitable for the refrigerant used.
  - Leak detection equipment shall be set at a percentage of the LFL of the refrigerant and shall be calibrated to the refrigerant employed and the appropriate percentage of gas (25 % maximum) is confirmed.
  - Leak detection fluids are also suitable for use with most refrigerants, for example, bubble method and fluorescent method agents. The use of detergents containing chlorine shall be avoided as the chlorine may react with the refrigerant and corrode the copper pipe-work.
  - If a leak is suspected, all naked flames shall be removed/extinguished.
  - If a leakage of refrigerant is found which requires brazing, all of the refrigerant shall be recovered from the system, or isolated (by means of shut off valves) in a part of the system remote from the leak. The precautions in #7 must be followed to remove the refrigerant.

 CAUTION

Removal and evacuation

- When breaking into the refrigerant circuit to make repairs – or for any other purpose – conventional procedures shall be used. However, it is important that best practice is followed since flammability is a consideration. The following procedure shall be adhered to:

- remove refrigerant -> • purge the circuit with inert gas -> • evacuate -> • purge with inert gas -> • open the circuit by cutting or brazing

- 7.
- The refrigerant charge shall be recovered into the correct recovery cylinders.
  - The system shall be purged with OFN to render the appliance safe. (remark: OFN = oxygen free nitrogen, type of inert gas)
  - This process may need to be repeated several times.
  - Compressed air or oxygen shall not be used for this task.
  - Purging shall be achieved by breaking the vacuum in the system with OFN and continuing to fill until the working pressure is achieved, then venting to atmosphere, and finally pulling down to a vacuum.
  - This process shall be repeated until no refrigerant is within the system.
  - When the final OFN charge is used, the system shall be vented down to atmospheric pressure to enable work to take place.
  - • This operation is absolutely vital if brazing operations on the pipe work are to take place.
  - • Ensure that the outlet for the vacuum pump is not close to any potential ignition sources and there is ventilation available.

Charging procedures

- 8.
- In addition to conventional charging procedures, the following requirements shall be followed.
    - Ensure that contamination of different refrigerants does not occur when using charging equipment.
    - Hoses or lines shall be as short as possible to minimize the amount of refrigerant contained in them.
    - Cylinders shall be kept in an appropriate position according to the instructions.
    - Ensure that the refrigerating system is earthed prior to charging the system with refrigerant.
    - Label the system when charging is complete (if not already).
    - Extreme care shall be taken not to over fill the refrigerating system.
  - Prior to recharging the system it shall be pressure tested with OFN (refer to #7).
  - The system shall be leak tested on completion of charging but prior to commissioning.
  - A follow up leak test shall be carried out prior to leaving the site.
  - Electrostatic charge may accumulate and create a hazardous condition when charging and discharging the refrigerant. To avoid fire or explosion, dissipate static electricity during transfer by grounding and bonding containers and equipment before charging/discharging.

Decommissioning

- Before carrying out this procedure, it is essential that the technician is completely familiar with the equipment and all its details.
  - It is recommended good practice that all refrigerants are recovered safely.
  - Prior to the task being carried out, an oil and refrigerant sample shall be taken in case analysis is required prior to re-use of reclaimed refrigerant.
  - It is essential that electrical power is available before the task is commenced.
    - a) Become familiar with the equipment and its operation.
    - b) Isolate system electrically.
    - c) Before attempting the procedure ensure that:
      - mechanical handling equipment is available, if required, for handling refrigerant cylinders;
      - all personal protective equipment is available and being used correctly;
      - the recovery process is supervised at all times by a competent person;
      - recovery equipment and cylinders conform to the appropriate standards.
- 9.
- d) Pump down refrigerant system, if possible.
  - e) If a vacuum is not possible, make a manifold so that refrigerant can be removed from various parts of the system.
  - f) Make sure that cylinder is situated on the scales before recovery takes place.
  - g) Start the recovery machine and operate in accordance with instructions.
  - h) Do not over fill cylinders. (No more than 80 % volume liquid charge).
  - i) Do not exceed the maximum working pressure of the cylinder, even temporarily.
  - j) When the cylinders have been filled correctly and the process completed, make sure that the cylinders and the equipment are removed from site promptly and all isolation valves on the equipment are closed off.
  - k) Recovered refrigerant shall not be charged into another refrigerating system unless it has been cleaned and checked.
  - Electrostatic charge may accumulate and create a hazardous condition when charging or discharging the refrigerant. To avoid fire or explosion, dissipate static electricity during transfer by grounding and bonding containers and equipment before charging/discharging.

Labelling

- 10.
- Equipment shall be labelled stating that it has been de-commissioned and emptied of refrigerant.
  - The label shall be dated and signed.
  - Ensure that there are labels on the equipment stating the equipment contains flammable refrigerant.

 **CAUTION**

Recovery

- When removing refrigerant from a system, either for servicing or decommissioning, it is recommended good practice that all refrigerants are removed safely.
  - When transferring refrigerant into cylinders, ensure that only appropriate refrigerant recovery cylinders are employed.
  - Ensure that the correct number of cylinders for holding the total system charge are available.
  - All cylinders to be used are designated for the recovered refrigerant and labelled for that refrigerant (i.e. special cylinders for the recovery of refrigerant).
  - Cylinders shall be complete with pressure relief valve and associated shut-off valves in good working order.
  - Recovery cylinders are evacuated and, if possible, cooled before recovery occurs.
  - The recovery equipment shall be in good working order with a set of instructions concerning the equipment that is at hand and shall be suitable for the recovery of concerning the equipment that is at hand and shall be suitable for the recovery of flammable refrigerants.
- 11.
- In addition, a set of calibrated weighing scales shall be available and in good working order.
  - Hoses shall be complete with leak-free disconnect couplings and in good condition.
  - Before using the recovery machine, check that it is in satisfactory working order, has been properly maintained and that any associated electrical components are sealed to prevent ignition in the event of a refrigerant release. Consult manufacturer if in doubt.
  - The recovered refrigerant shall be returned to the refrigerant supplier in the correct recovery cylinder, and the relevant Waste Transfer Note arranged.
  - Do not mix refrigerants in recovery units and especially not in cylinders.
  - If compressors or compressor oils are to be removed, ensure that they have been evacuated to an acceptable level to make certain that flammable refrigerant does not remain within the lubricant.
  - The evacuation process shall be carried out prior to returning the compressor to the suppliers.
  - Only electric heating to the compressor body shall be employed to accelerate this process.
  - When oil is drained from a system, it shall be carried out safely.

### 3. Specifications

Model		Indoor	CS-Z25YKEA			
		Outdoor	CU-Z25YKEA			
Performance Test Condition		EUROVENT				
Power Supply		Phase, Hz	Single, 50			
		V	230			
		Min.	Mid.	Max.		
Cooling	Capacity		kW	0.85	2.50	3.50
			BTU/h	2900	8530	11900
			kcal/h	730	2150	3010
	Running Current		A	-	2.35	-
	Input Power		W	180	510	880
	Annual Consumption		kWh	-	255	-
	EER Class			-	A	-
	EER		W/W	4.72	4.90	3.98
			BTU/hW	16.11	16.73	13.52
			kcal/hW	4.06	4.22	3.42
	ErP	Pdesign		kW	2.5	
		SEER		(W/W)	9.5	
		Annual Consumption		kWh	92	
		Class			A+++	
	Power Factor		%	-	94	-
	Indoor Noise (H / L / QLo)		Pressure Level dB (A)	39 / 25 / 21		
			Power Level dB (A)	55 / - / -		
	Outdoor Noise (H / L / QLo)		Pressure Level dB (A)	46 / - / -		
			Power Level dB (A)	61 / - / -		
	Heating	Capacity		kW	0.85	3.40
BTU/h				2900	11600	17100
kcal/h				730	2920	4300
Running Current		A	-	3.25	-	
Input Power		W	180	700	1.26k	
COP CLASS			-	A	-	
COP		W/W	4.72	4.86	3.97	
		BTU/hW	16.11	16.57	13.57	
		kcal/hW	4.06	4.17	3.41	
ErP		Pdesign		kW	2.7	
		Tbivalent		°C	-10	
		SCOP		(W/W)	4.6	
		Annual Consumption		kWh	822	
		Class			A++	
Power Factor		%	-	94	-	
Indoor Noise (H / L / QLo)		Pressure Level dB (A)	41 / 27 / 22			
		Power Level dB (A)	57 / - / -			
Outdoor Noise (H / L / QLo)		Pressure Level dB (A)	48 / - / -			
		Power Level dB (A)	63 / - / -			
LOW Temp: Capacity (kW) / I. Power (W) / COP				3.62 / 1.12k / 3.23		
EXTR LOW Temp: Capacity (kW) / I. Power (W) / COP				3.05 / 1.10k / 2.77		
Max Current (A) / Max Input Power (W)				5.6 / 1.26k		
Starting Current (A)				3.25		

Model			Indoor	CS-Z25YKEA	
			Outdoor	CU-Z25YKEA	
Compressor	Type			Hermetic Motor / Rotary	
	Motor Type			Brushless (6-poles)	
	Output Power		W	700	
Indoor Fan	Type			Cross-flow fan	
	Material			ASG30	
	Motor Type			DC (8-pole)	
	Input Power		W	47.1	
	Output Power		W	40	
	Speed	QLo	Cool	rpm	500
			Heat	rpm	570
		Lo	Cool	rpm	610
			Heat	rpm	690
		Me	Cool	rpm	770
			Heat	rpm	890
		Hi	Cool	rpm	920
Heat			rpm	1070	
SHi	Cool	rpm	980		
	Heat	rpm	1130		
Outdoor Fan	Type			Propeller Fan	
	Material			PP	
	Motor Type			DC (8-pole)	
	Input Power		W	-	
	Output Power		W	40	
	Speed	Hi	Cool	rpm	790
Heat			rpm	790	
Moisture Removal			L/h (Pt/h)	1.5 (3.2)	
Indoor Airflow	QLo	Cool	m <sup>3</sup> /min (ft <sup>3</sup> /min)	5.30 (187)	
		Heat	m <sup>3</sup> /min (ft <sup>3</sup> /min)	5.93 (209)	
	Lo	Cool	m <sup>3</sup> /min (ft <sup>3</sup> /min)	6.56 (232)	
		Heat	m <sup>3</sup> /min (ft <sup>3</sup> /min)	7.82 (276)	
	Me	Cool	m <sup>3</sup> /min (ft <sup>3</sup> /min)	9.08 (321)	
		Heat	m <sup>3</sup> /min (ft <sup>3</sup> /min)	10.97 (387)	
	Hi	Cool	m <sup>3</sup> /min (ft <sup>3</sup> /min)	11.40 (400)	
		Heat	m <sup>3</sup> /min (ft <sup>3</sup> /min)	13.80 (485)	
	SHi	Cool	m <sup>3</sup> /min (ft <sup>3</sup> /min)	12.39 (437)	
		Heat	m <sup>3</sup> /min (ft <sup>3</sup> /min)	14.75 (521)	
Outdoor Airflow	Hi	Cool	m <sup>3</sup> /min (ft <sup>3</sup> /min)	27.60 (975)	
		Heat	m <sup>3</sup> /min (ft <sup>3</sup> /min)	27.60 (975)	
Refrigerant Cycle	Control Device			Expansion Valve	
	Refrigerant Oil		cm <sup>3</sup>	FW50S (320)	
	Refrigerant Type		kg (oz)	R32, 0.89 (31.4)	
F-Gas	GWP			675	
	CO <sub>2</sub> eq (ton) (Precharge Amount / Maximum Charged Amount)			0.60 / 0.69	

Model			Indoor	CS-Z25YKEA
			Outdoor	CU-Z25YKEA
Dimension	Unit	Height (ID / OD)	mm (inch)	295 (11-5/8) / 542 (21-11/32)
		Width (ID / OD)	mm (inch)	870 (34-9/32) / 780 (30-23/32)
		Depth (ID / OD)	mm (inch)	229 (9-1/32) / 289 (11-13/32)
Weight	Net (I/D / O/D)		kg (lb)	11 (24) / 30 (66)
Piping	Pipe Diameter (Liquid / Gas)		mm (inch)	6.35 (1/4) / 9.52 (3/8)
	Standard Length		m (ft)	5.0 (16.4)
	Length Range (min - max)		m (ft)	3 (9.8) ~ 20 (65.6)
	I/D & O/D Height Different		m (ft)	15.0 (49.2)
	Additional Gas Amount		g/m (oz/ft)	10 (0.1)
	Length for Additional Gas		m (ft)	7.5 (24.6)
Drain Hose	Inner Diameter		mm	16.7
	Length		mm	650
Indoor Heat Exchanger	Fin Material			Aluminium (Pre coat)
	Fin Type			Slit Fin
	Row x Stage x FPI			2 x 17 x 21
	Size (W x H x L)		mm	644.5 x 357 x 25.4
Outdoor Heat Exchanger	Fin Material			Aluminium (Pre coat)
	Fin Type			Corrugated Fin
	Row x Stage x FPI			2 x 24 x 19
	Size (W x H x L)		mm	36.4 x 504 x 824.2:793.7
Air Filter	Material			Polypropelene
	Type			One-touch
Power Supply				Indoor
Power Supply Cord				NIL
Thermostat				Electronic Control
Protection Device				Electronic Control
			Dry Bulb	Wet Bulb
Indoor Operation Range	Cooling	Maximum °C (°F)	32 (89.6)	23 (73.4)
		Minimum °C (°F)	16 (60.8)	11 (51.8)
	Heating	Maximum °C (°F)	30 (86.0)	-
		Minimum °C (°F)	16 (60.8)	-
Outdoor Operation Range	Cooling	Maximum °C (°F)	43 (109.4)	26 (78.8)
		Minimum °C (°F)	-25 (-13.0)	-
	Heating	Maximum °C (°F)	24 (75.2)	18 (64.4)
		Minimum °C (°F)	-15 (5.0)	-

- Cooling capacities are based on indoor temperature of 27°C Dry Bulb (80.6°F Dry Bulb), 19.0°C Wet Bulb (66.2°F Wet Bulb) and outdoor air temperature of 35°C DRY BULB (95°F Dry Bulb), 24°C Wet Bulb (75.2°F Wet Bulb).
- Heating capacities are based on indoor temperature of 20°C Dry Bulb (68°F Dry Bulb) and outdoor air temperature of 7°C Dry Bulb (44.6°F Dry Bulb), 6°C Wet Bulb (42.8°F Wet Bulb).
- Network Impedance shall be applicable for Europe models only.
- The annual consumption is calculated by multiplying the input power by an average of 500 hours per year in cooling mode.
- EER and COP Class: Refer Att 11, RAD-A-04-06, eg. Europe: classification is at 230V only in accordance with EU directive 2003/31/EC, A – G, Australia: n star, Singapore: Tick n, etc.
- Heating low temperature capacity, Input Power and COP measured at 230 V, indoor temperature 20°C, outdoor 2/1°C.
- Heating extreme low temperature capacity, Input Power and COP measured at 230 V, indoor temperature 20°C, outdoor -7/-8°C.
- Standby power consumption ≤2.0W (when switched OFF by remote control, except under self protection control).
- Specifications are subjected to change without prior notice for further improvement.
- SEER and SCOP classification is at 230V only in accordance with EN-14825. For heating, SCOP indicates the value of only Average heating season.

Model		Indoor	CS-Z35YKEA			
		Outdoor	CU-Z35YKEA			
Performance Test Condition		EUROVENT				
Power Supply		Phase, Hz	Single, 50			
		V	230			
		Min.	Mid.	Max.		
Cooling	Capacity	kW	0.85	3.50	4.20	
		BTU/h	2900	11900	14300	
		kcal/h	730	3010	3610	
	Running Current	A	-	3.80	-	
	Input Power	W	180	850	1.14k	
	Annual Consumption	kWh	-	425	-	
	EER CLASS		-	A	-	
	EER	W/W	4.72	4.12	3.68	
		BTU/hW	16.11	14.00	12.54	
		kcal/hW	4.06	3.54	3.17	
	ErP	Pdesign	kW	3.5		
		SEER	(W/W)	9.6		
		Annual Consumption	kWh	128		
		Class		A+++		
	Power Factor	%	-	97	-	
	Indoor Noise (H / L / QLo)	Pressure Level dB (A)	42 / 28 / 21			
		Power Level dB (A)	58 / - / -			
Outdoor Noise (H / L / QLo)	Pressure Level dB (A)	48 / - / -				
	Power Level dB (A)	63 / - / -				
Heating	Capacity	kW	0.85	4.00	5.80	
		BTU/h	2900	13600	19800	
		kcal/h	730	3440	4990	
	Running Current	A	-	4.00	-	
	Input Power	W	180	900	1.50k	
	COP CLASS		-	A	-	
	COP	W/W	4.72	4.44	3.87	
		BTU/hW	16.11	15.11	13.20	
		kcal/hW	4.06	3.82	3.33	
	ErP	Pdesign	kW	3.2		
		Tbivalent	°C	-10		
		SCOP	(W/W)	4.6		
		Annual Consumption	kWh	974		
		Class		A++		
	Power Factor	%	-	98	-	
	Indoor Noise (H / L / QLo)	Pressure Level dB (A)	43 / 30 / 22			
		Power Level dB (A)	59 / - / -			
Outdoor Noise (H / L / QLo)	Pressure Level dB (A)	50 / - / -				
	Power Level dB (A)	65 / - / -				
LOW Temp: Capacity (kW) / I. Power (W) / COP		4.20 / 1.33k / 3.16				
EXTR LOW Temp: Capacity (kW) / I. Power (W) / COP		3.40 / 1.30k / 2.62				
Max Current (A) / Max Input Power (W)		6.6 / 1.50k				
Starting Current (A)		4.00				

Model			Indoor	CS-Z35YKEA	
			Outdoor	CU-Z35YKEA	
Compressor	Type			Hermetic Motor / Rotary	
	Motor Type			Brushless (6-poles)	
	Output Power		W	700	
Indoor Fan	Type			Cross-flow fan	
	Material			ASG30	
	Motor Type			DC (8-pole)	
	Input Power		W	47.1	
	Output Power		W	40	
	Speed	QLo	Cool	rpm	530
			Heat	rpm	570
		Lo	Cool	rpm	670
			Heat	rpm	750
		Me	Cool	rpm	830
			Heat	rpm	930
		Hi	Cool	rpm	1000
			Heat	rpm	1130
SHi	Cool	rpm	1060		
	Heat	rpm	1190		
Outdoor Fan	Type			Propeller Fan	
	Material			PP	
	Motor Type			DC (8-pole)	
	Input Power		W	-	
	Output Power		W	40	
	Speed	Hi	Cool	rpm	850
Heat			rpm	850	
Moisture Removal			L/h (Pt/h)	2.0 (4.2)	
Indoor Airflow	QLo	Cool	m <sup>3</sup> /min (ft <sup>3</sup> /min)	5.30 (187)	
		Heat	m <sup>3</sup> /min (ft <sup>3</sup> /min)	5.93 (209)	
	Lo	Cool	m <sup>3</sup> /min (ft <sup>3</sup> /min)	7.50 (265)	
		Heat	m <sup>3</sup> /min (ft <sup>3</sup> /min)	8.76 (309)	
	Me	Cool	m <sup>3</sup> /min (ft <sup>3</sup> /min)	10.02 (354)	
		Heat	m <sup>3</sup> /min (ft <sup>3</sup> /min)	11.60 (410)	
	Hi	Cool	m <sup>3</sup> /min (ft <sup>3</sup> /min)	12.70 (450)	
		Heat	m <sup>3</sup> /min (ft <sup>3</sup> /min)	14.80 (520)	
SHi	Cool	m <sup>3</sup> /min (ft <sup>3</sup> /min)	13.65 (482)		
	Heat	m <sup>3</sup> /min (ft <sup>3</sup> /min)	15.69 (554)		
Outdoor Airflow	Hi	Cool	m <sup>3</sup> /min (ft <sup>3</sup> /min)	29.80 (1050)	
		Heat	m <sup>3</sup> /min (ft <sup>3</sup> /min)	29.80 (1050)	
Refrigerant Cycle	Control Device			Expansion Valve	
	Refrigerant Oil		cm <sup>3</sup>	FW50S (320)	
	Refrigerant Type		kg (oz)	R32, 0.89 (31.4)	
F-Gas	GWP			675	
	CO <sub>2</sub> eq (ton) (Precharge Amount / Maximum Charged Amount)			0.60 / 0.69	

Model			Indoor	CS-Z35YKEA
			Outdoor	CU-Z35YKEA
Dimension	Unit	Height (ID / OD)	mm (inch)	295 (11-5/8) / 542 (21-11/32)
		Width (ID / OD)	mm (inch)	870 (34-9/32) / 780 (30-23/32)
		Depth (ID / OD)	mm (inch)	229 (9-1/32) / 289 (11-13/32)
Weight	Net (I/D / O/D)		kg (lb)	11 (24) / 30 (66)
Piping	Pipe Diameter (Liquid / Gas)		mm (inch)	6.35 (1/4) / 9.52 (3/8)
	Standard Length		m (ft)	5.0 (16.4)
	Length Range (min - max)		m (ft)	3 (9.8) ~ 20 (65.6)
	I/D & O/D Height Different		m (ft)	15.0 (49.2)
	Additional Gas Amount		g/m (oz/ft)	10 (0.1)
	Length for Additional Gas		m (ft)	7.5 (24.6)
Drain Hose	Inner Diameter		mm	16.7
	Length		mm	650
Indoor Heat Exchanger	Fin Material			Aluminium (Pre coat)
	Fin Type			Slit Fin
	Row x Stage x FPI			2 x 17 x 21
	Size (W x H x L)		mm	644.5 x 357 x 25.4
Outdoor Heat Exchanger	Fin Material			Aluminium (Pre coat)
	Fin Type			Corrugated Fin
	Row x Stage x FPI			2 x 24 x 19
	Size (W x H x L)		mm	36.4 x 504 x 824.2:793.7
Air Filter	Material			Polypropelene
	Type			One-touch
Power Supply				Indoor
Power Supply Cord				NIL
Thermostat				Electronic Control
Protection Device				Electronic Control
				Dry Bulb
				Wet Bulb
Indoor Operation Range	Cooling	Maximum °C (°F)	32 (89.6)	23 (73.4)
		Minimum °C (°F)	16 (60.8)	11 (51.8)
	Heating	Maximum °C (°F)	30 (86.0)	-
		Minimum °C (°F)	16 (60.8)	-
Outdoor Operation Range	Cooling	Maximum °C (°F)	43 (109.4)	26 (78.8)
		Minimum °C (°F)	-25 (-13.0)	-
	Heating	Maximum °C (°F)	24 (75.2)	18 (64.4)
		Minimum °C (°F)	-15 (5.0)	-

- Cooling capacities are based on indoor temperature of 27°C Dry Bulb (80.6°F Dry Bulb), 19.0°C Wet Bulb (66.2°F Wet Bulb) and outdoor air temperature of 35°C DRY BULB (95°F Dry Bulb), 24°C Wet Bulb (75.2°F Wet Bulb).
- Heating capacities are based on indoor temperature of 20°C Dry Bulb (68°F Dry Bulb) and outdoor air temperature of 7°C Dry Bulb (44.6°F Dry Bulb), 6°C Wet Bulb (42.8°F Wet Bulb).
- Network Impedance shall be applicable for Europe models only.
- The annual consumption is calculated by multiplying the input power by an average of 500 hours per year in cooling mode.
- EER and COP Class: Refer Att 11, RAD-A-04-06, eg. Europe: classification is at 230V only in accordance with EU directive 2003/31/EC, A – G, Australia: n star, Singapore: Tick n, etc.
- Heating low temperature capacity, Input Power and COP measured at 230 V, indoor temperature 20°C, outdoor 2/1°C.
- Heating extreme low temperature capacity, Input Power and COP measured at 230 V, indoor temperature 20°C, outdoor -7/-8°C.
- Standby power consumption ≤2.0W (when switched OFF by remote control, except under self protection control).
- Specifications are subjected to change without prior notice for further improvement.
- SEER and SCOP classification is at 230V only in accordance with EN-14825. For heating, SCOP indicates the value of only Average heating season.

Model		Indoor	CS-Z42YKEA			
		Outdoor	CU-Z42YKEA			
Performance Test Condition		EUROVENT				
Power Supply		Phase, Hz	Single, 50			
		V	230			
		Min.	Mid.	Max.		
Cooling	Capacity		kW	0.85	4.20	5.00
			BTU/h	2900	14300	17100
			kcal/h	730	3610	4300
	Running Current		A	-	4.90	-
	Input Power		W	180	1.10k	1.54k
	Annual Consumption		kWh	-	550	-
	EER CLASS			-	A	-
	EER		W/W	4.72	3.82	3.25
			BTU/hW	16.11	13.00	11.10
			kcal/hW	4.06	3.28	2.79
	ErP	Pdesign		kW	4.2	
		SEER		(W/W)	8.6	
		Annual Consumption		kWh	171	
		Class			A+++	
	Power Factor		%	-	98	-
	Indoor Noise (H / L / QLo)		Pressure Level dB (A)	43 / 32 / 29		
			Power Level dB (A)	59 / - / -		
Outdoor Noise (H / L / QLo)		Pressure Level dB (A)	48 / - / -			
		Power Level dB (A)	63 / - / -			
Heating	Capacity		kW	0.85	5.30	6.80
			BTU/h	2900	18100	23200
			kcal/h	730	4560	5850
	Running Current		A	-	5.90	-
	Input Power		W	180	1.35k	1.86k
	COP CLASS			-	A	-
	COP		W/W	4.72	3.93	3.66
			BTU/hW	16.11	13.41	12.47
			kcal/hW	4.06	3.38	3.15
	ErP	Pdesign		kW	3.6	
		Tbivalent		°C	-10	
		SCOP		(W/W)	4.5	
		Annual Consumption		kWh	1120	
		Class			A+	
	Power Factor		%	-	99	-
	Indoor Noise (H / L / QLo)		Pressure Level dB (A)	44 / 35 / 29		
			Power Level dB (A)	60 / - / -		
Outdoor Noise (H / L / QLo)		Pressure Level dB (A)	51 / - / -			
		Power Level dB (A)	66 / - / -			
LOW Temp: Capacity (kW) / I. Power (W) / COP			4.93 / 1.65k / 2.99			
EXTR LOW Temp: Capacity (kW) / I. Power (W) / COP			4.11 / 1.60k / 2.57			
Max Current (A) / Max Input Power (W)			8.1 / 1.86k			
Starting Current (A)			5.90			

Model			Indoor	CS-Z42YKEA	
			Outdoor	CU-Z42YKEA	
Compressor	Type			Hermetic Motor / Rotary	
	Motor Type			Brushless (6-poles)	
	Output Power		W	700	
Indoor Fan	Type			Cross-flow fan	
	Material			ASG30	
	Motor Type			DC (8-pole)	
	Input Power		W	47.1	
	Output Power		W	40	
	Speed	QLo	Cool	rpm	680
			Heat	rpm	750
		Lo	Cool	rpm	750
			Heat	rpm	870
		Me	Cool	rpm	890
			Heat	rpm	1010
		Hi	Cool	rpm	1030
Heat			rpm	1160	
SHi	Cool	rpm	1090		
	Heat	rpm	1220		
Outdoor Fan	Type			Propeller Fan	
	Material			PP	
	Motor Type			DC (8-pole)	
	Input Power		W	-	
	Output Power		W	40	
	Speed	Hi	Cool	rpm	850
Heat			rpm	880	
Moisture Removal			L/h (Pt/h)	2.4 (5.1)	
Indoor Airflow	QLo	Cool	m <sup>3</sup> /min (ft <sup>3</sup> /min)	7.66 (270)	
		Heat	m <sup>3</sup> /min (ft <sup>3</sup> /min)	8.76 (309)	
	Lo	Cool	m <sup>3</sup> /min (ft <sup>3</sup> /min)	8.76 (309)	
		Heat	m <sup>3</sup> /min (ft <sup>3</sup> /min)	10.65 (376)	
	Me	Cool	m <sup>3</sup> /min (ft <sup>3</sup> /min)	10.97 (387)	
		Heat	m <sup>3</sup> /min (ft <sup>3</sup> /min)	12.86 (454)	
	Hi	Cool	m <sup>3</sup> /min (ft <sup>3</sup> /min)	13.20 (465)	
		Heat	m <sup>3</sup> /min (ft <sup>3</sup> /min)	15.20 (535)	
	SHi	Cool	m <sup>3</sup> /min (ft <sup>3</sup> /min)	14.12 (499)	
		Heat	m <sup>3</sup> /min (ft <sup>3</sup> /min)	16.17 (571)	
Outdoor Airflow	Hi	Cool	m <sup>3</sup> /min (ft <sup>3</sup> /min)	29.8 (1050)	
		Heat	m <sup>3</sup> /min (ft <sup>3</sup> /min)	31.0 (1095)	
Refrigerant Cycle	Control Device			Expansion Valve	
	Refrigerant Oil		cm <sup>3</sup>	FW50S (320)	
	Refrigerant Type		kg (oz)	R32, 0.97 (34.2)	
F-Gas	GWP			675	
	CO <sub>2</sub> eq (ton) (Precharge Amount / Maximum Charged Amount)			0.65 / 0.74	

Model			Indoor	CS-Z42YKEA
			Outdoor	CU-Z42YKEA
Dimension	Unit	Height (ID / OD)	mm (inch)	295 (11-5/8) / 542 (21-11/32)
		Width (ID / OD)	mm (inch)	870 (34-9/32) / 780 (30-23/32)
		Depth (ID / OD)	mm (inch)	229 (9-1/32) / 289 (11-13/32)
Weight	Net (I/D / O/D)		kg (lb)	11 (24) / 30 (66)
Piping	Pipe Diameter (Liquid / Gas)		mm (inch)	6.35 (1/4) / 12.70 (1/2)
	Standard Length		m (ft)	5.0 (16.4)
	Length Range (min - max)		m (ft)	3 (9.8) ~ 20 (65.6)
	I/D & O/D Height Different		m (ft)	15.0 (49.2)
	Additional Gas Amount		g/m (oz/ft)	10 (0.1)
	Length for Additional Gas		m (ft)	7.5 (24.6)
Drain Hose	Inner Diameter		mm	16.7
	Length		mm	650
Indoor Heat Exchanger	Fin Material			Aluminium (Pre coat)
	Fin Type			Slit Fin
	Row x Stage x FPI			2 x 17 x 21
	Size (W x H x L)		mm	644.5 x 357 x 25.4
Outdoor Heat Exchanger	Fin Material			Aluminium (Pre coat)
	Fin Type			Corrugated Fin
	Row x Stage x FPI			2 x 24 x 19
	Size (W x H x L)		mm	36.4 x 504 x 824.2:793.7
Air Filter	Material			Polypropelene
	Type			One-touch
Power Supply				Indoor
Power Supply Cord				NIL
Thermostat				Electronic Control
Protection Device				Electronic Control
				Dry Bulb
				Wet Bulb
Indoor Operation Range	Cooling	Maximum °C (°F)	32 (89.6)	23 (73.4)
		Minimum °C (°F)	16 (60.8)	11 (51.8)
	Heating	Maximum °C (°F)	30 (86.0)	-
		Minimum °C (°F)	16 (60.8)	-
Outdoor Operation Range	Cooling	Maximum °C (°F)	43 (109.4)	26 (78.8)
		Minimum °C (°F)	-25 (-13.0)	-
	Heating	Maximum °C (°F)	24 (75.2)	18 (64.4)
		Minimum °C (°F)	-15 (5.0)	-

- Cooling capacities are based on indoor temperature of 27°C Dry Bulb (80.6°F Dry Bulb), 19.0°C Wet Bulb (66.2°F Wet Bulb) and outdoor air temperature of 35°C DRY BULB (95°F Dry Bulb), 24°C Wet Bulb (75.2°F Wet Bulb).
- Heating capacities are based on indoor temperature of 20°C Dry Bulb (68°F Dry Bulb) and outdoor air temperature of 7°C Dry Bulb (44.6°F Dry Bulb), 6°C Wet Bulb (42.8°F Wet Bulb).
- Network Impedance shall be applicable for Europe models only.
- The annual consumption is calculated by multiplying the input power by an average of 500 hours per year in cooling mode.
- EER and COP Class: Refer Att 11, RAD-A-04-06, eg. Europe: classification is at 230V only in accordance with EU directive 2003/31/EC, A – G, Australia: n star, Singapore: Tick n, etc.
- Heating low temperature capacity, Input Power and COP measured at 230 V, indoor temperature 20°C, outdoor 2/1°C.
- Heating extreme low temperature capacity, Input Power and COP measured at 230 V, indoor temperature 20°C, outdoor -7/-8°C.
- Standby power consumption ≤2.0W (when switched OFF by remote control, except under self protection control).
- Specifications are subjected to change without prior notice for further improvement.
- SEER and SCOP classification is at 230V only in accordance with EN-14825. For heating, SCOP indicates the value of only Average heating season.

Model		Indoor	CS-Z50YKEA			
		Outdoor	CU-Z50YKEA			
Performance Test Condition		EUROVENT				
Power Supply		Phase, Hz	Single, 50			
		V	230			
		Min.	Mid.	Max.		
Cooling	Capacity		kW	0.98	5.00	6.00
			BTU/h	3340	17100	20500
			kcal/h	840	4300	5160
	Running Current		A	-	6.00	-
	Input Power		W	250	1.36k	1.90k
	Annual Consumption		kWh	-	680	-
	EER CLASS			-	A	-
	EER		W/W	3.92	3.68	3.16
			BTU/hW	13.36	12.57	10.79
			kcal/hW	3.36	3.16	2.72
	ErP	Pdesign		kW	5.0	
		SEER		(W/W)	8.6	
		Annual Consumption		kWh	203	
		Class			A+++	
	Power Factor		%	-	99	-
	Indoor Noise (H / L / QLo)		Pressure Level dB (A)	44 / 37 / 30		
			Power Level dB (A)	60 / - / -		
	Outdoor Noise (H / L / QLo)		Pressure Level dB (A)	48 / - / -		
Power Level dB (A)			63 / - / -			
Heating	Capacity		kW	0.98	5.80	8.00
			BTU/h	3340	19800	27300
			kcal/h	840	4990	6880
	Running Current		A	-	6.30	-
	Input Power		W	230	1.42k	2.39k
	COP CLASS			-	A	-
	COP		W/W	4.26	4.08	3.35
			BTU/hW	14.52	13.94	11.42
			kcal/hW	3.65	3.51	2.88
	ErP	Pdesign		kW	4.2	
		Tbivalent		°C	-10	
		SCOP		(W/W)	4.6	
		Annual Consumption		kWh	1278	
		Class			A++	
	Power Factor		%	-	98	-
	Indoor Noise (H / L / QLo)		Pressure Level dB (A)	44 / 37 / 30		
			Power Level dB (A)	60 / - / -		
	Outdoor Noise (H / L / QLo)		Pressure Level dB (A)	50 / - / -		
Power Level dB (A)			65 / - / -			
LOW Temp: Capacity (kW) / I. Power (W) / COP				5.80 / 2.12k / 2.74		
EXTR LOW Temp: Capacity (kW) / I. Power (W) / COP				4.80 / 1.88k / 2.55		
Max Current (A) / Max Input Power (W)				10.5 / 2.39k		
Starting Current (A)				6.30		

Model			Indoor	CS-Z50YKEA	
			Outdoor	CU-Z50YKEA	
Compressor	Type			Hermetic Motor / Rotary	
	Motor Type			Brushless (6-pole)	
	Output Power		W	900	
Indoor Fan	Type			Cross-flow fan	
	Material			ASG30	
	Motor Type			DC (8-pole)	
	Input Power		W	74.0	
	Output Power		W	40	
	Speed	QLo	Cool	rpm	670
			Heat	rpm	690
		Lo	Cool	rpm	860
			Heat	rpm	870
		Me	Cool	rpm	960
			Heat	rpm	1010
		Hi	Cool	rpm	1050
			Heat	rpm	1140
SHi	Cool	rpm	1100		
	Heat	rpm	1210		
Outdoor Fan	Type			Propeller Fan	
	Material			PP	
	Motor Type			DC (8-pole)	
	Input Power		W	-	
	Output Power		W	40	
	Speed	Hi	Cool	rpm	720
Heat			rpm	670	
Moisture Removal			L/h (Pt/h)	2.8 (5.9)	
Indoor Airflow	QLo	Cool	m <sup>3</sup> /min (ft <sup>3</sup> /min)	10.41 (368)	
		Heat	m <sup>3</sup> /min (ft <sup>3</sup> /min)	10.81 (382)	
	Lo	Cool	m <sup>3</sup> /min (ft <sup>3</sup> /min)	13.90 (491)	
		Heat	m <sup>3</sup> /min (ft <sup>3</sup> /min)	14.13 (499)	
	Me	Cool	m <sup>3</sup> /min (ft <sup>3</sup> /min)	15.74 (556)	
		Heat	m <sup>3</sup> /min (ft <sup>3</sup> /min)	16.71 (590)	
	Hi	Cool	m <sup>3</sup> /min (ft <sup>3</sup> /min)	17.40 (615)	
		Heat	m <sup>3</sup> /min (ft <sup>3</sup> /min)	19.10 (675)	
SHi	Cool	m <sup>3</sup> /min (ft <sup>3</sup> /min)	18.31 (647)		
	Heat	m <sup>3</sup> /min (ft <sup>3</sup> /min)	20.40 (720)		
Outdoor Airflow	Hi	Cool	m <sup>3</sup> /min (ft <sup>3</sup> /min)	39.80 (1405)	
		Heat	m <sup>3</sup> /min (ft <sup>3</sup> /min)	36.90 (1305)	
Refrigerant Cycle	Control Device			Expansion Valve	
	Refrigerant Oil		cm <sup>3</sup>	FW50S (450)	
	Refrigerant Type		kg (oz)	R32, 1.13 (39.9)	
F-Gas	GWP			675	
	CO <sub>2</sub> eq (ton) (Precharge Amount / Maximum Charged Amount)			0.76 / 0.99	

Model			Indoor	CS-Z50YKEA
			Outdoor	CU-Z50YKEA
Dimension	Unit	Height (ID / OD)	mm (inch)	295 (11-5/8) / 695 (27-3/8)
		Width (ID / OD)	mm (inch)	1040 (40-31/32) / 875 (34-15/32)
		Depth (ID / OD)	mm (inch)	244 (9-5/8) / 320 (12-5/8)
Weight	Net (I/D / O/D)		kg (lb)	12 (26) / 40 (88)
Piping	Pipe Diameter (Liquid / Gas)		mm (inch)	6.35 (1/4) / 12.7 (1/2)
	Standard Length		m (ft)	5.0 (16.4)
	Length Range (min - max)		m (ft)	3 (9.8) ~ 30 (98.4)
	I/D & O/D Height Different		m (ft)	15.0 (49.2)
	Additional Gas Amount		g/m (oz/ft)	15 (0.2)
	Length for Additional Gas		m (ft)	7.5 (24.6)
Drain Hose	Inner Diameter		mm	16.7
	Length		mm	650
Indoor Heat Exchanger	Fin Material			Aluminium (Pre coat)
	Fin Type			Slit Fin
	Row x Stage x FPI			2 x 17 x 21
	Size (W x H x L)		mm	814.5 x 357 x 25.4
Outdoor Heat Exchanger	Fin Material			Aluminium (Pre coat)
	Fin Type			Corrugated Fin
	Row x Stage x FPI			2 x 31 x 19
	Size (W x H x L)		mm	36.4 x 651 x 854.5:824.5
Air Filter	Material			Polypropelene
	Type			One-touch
Power Supply				Indoor
Power Supply Cord				NIL
Thermostat				Electronic Control
Protection Device				Electronic Control
				Dry Bulb
				Wet Bulb
Indoor Operation Range	Cooling	Maximum °C (°F)	32 (89.6)	23 (73.4)
		Minimum °C (°F)	16 (60.8)	11 (51.8)
	Heating	Maximum °C (°F)	30 (86.0)	-
		Minimum °C (°F)	16 (60.8)	-
Outdoor Operation Range	Cooling	Maximum °C (°F)	43 (109.4)	26 (78.8)
		Minimum °C (°F)	-25 (-13.0)	-
	Heating	Maximum °C (°F)	24 (75.2)	18 (64.4)
		Minimum °C (°F)	-15 (5.0)	-

- Cooling capacities are based on indoor temperature of 27°C Dry Bulb (80.6°F Dry Bulb), 19.0°C Wet Bulb (66.2°F Wet Bulb) and outdoor air temperature of 35°C DRY BULB (95°F Dry Bulb), 24°C Wet Bulb (75.2°F Wet Bulb).
- Heating capacities are based on indoor temperature of 20°C Dry Bulb (68°F Dry Bulb) and outdoor air temperature of 7°C Dry Bulb (44.6°F Dry Bulb), 6°C Wet Bulb (42.8°F Wet Bulb).
- Network Impedance shall be applicable for Europe models only.
- The annual consumption is calculated by multiplying the input power by an average of 500 hours per year in cooling mode.
- EER and COP Class: Refer Att 11, RAD-A-04-06, eg. Europe: classification is at 230V only in accordance with EU directive 2003/31/EC, A – G, Australia: n star, Singapore: Tick n, etc.
- Heating low temperature capacity, Input Power and COP measured at 230 V, indoor temperature 20°C, outdoor 2/1°C.
- Heating extreme low temperature capacity, Input Power and COP measured at 230 V, indoor temperature 20°C, outdoor -7/-8°C.
- Standby power consumption ≤2.0W (when switched OFF by remote control, except under self protection control).
- Specifications are subjected to change without prior notice for further improvement.
- SEER and SCOP classification is at 230V only in accordance with EN-14825. For heating, SCOP indicates the value of only Average heating season.

Model		Indoor	CS-Z71YKEA			
		Outdoor	CU-Z71YKEA			
Performance Test Condition		EUROVENT				
Power Supply		Phase, Hz	Single, 50			
		V	230			
		Min.	Mid.	Max.		
Cooling	Capacity		kW	0.98	7.10	8.50
			BTU/h	3340	24200	29000
			kcal/h	840	6110	7310
	Running Current		A	-	9.80	-
	Input Power		W	420	2.20k	3.00k
	Annual Consumption		kWh	-	1100	-
	EER CLASS			-	A	-
	EER		W/W	2.33	3.23	2.83
			BTU/hW	7.95	11.00	9.67
			kcal/hW	2.00	2.78	2.44
	ErP	Pdesign		kW	7.1	
		SEER		(W/W)	6.5	
		Annual Consumption		kWh	382	
		Class			A++	
	Power Factor		%	-	98	-
	Indoor Noise (H / L / QLo)		Pressure Level dB (A)	47 / 38 / 35		
			Power Level dB (A)	63 / - / -		
	Outdoor Noise (H / L / QLo)		Pressure Level dB (A)	52 / - / -		
Power Level dB (A)			66 / - / -			
Heating	Capacity		kW	0.98	8.20	10.20
			BTU/h	3340	28000	34800
			kcal/h	840	7050	8770
	Running Current		A	-	9.80	-
	Input Power		W	400	2.21k	3.10k
	COP CLASS			-	A	-
	COP		W/W	2.45	3.71	3.29
			BTU/hW	8.35	12.67	11.23
			kcal/hW	2.10	3.19	2.83
	ErP	Pdesign		kW	5.5	
		Tbivalent		°C	-10	
		SCOP		(W/W)	4.1	
		Annual Consumption		kWh	1878	
		Class			A+	
	Power Factor		%	-	98	-
	Indoor Noise (H / L / QLo)		Pressure Level dB (A)	47 / 38 / 35		
			Power Level dB (A)	63 / - / -		
	Outdoor Noise (H / L / QLo)		Pressure Level dB (A)	54 / - / -		
Power Level dB (A)			68 / - / -			
LOW Temp: Capacity (kW) / I. Power (W) / COP		7.39 / 2.74k / 2.70				
EXTR LOW Temp: Capacity (kW) / I. Power (W) / COP		6.31 / 2.60k / 2.43				
Max Current (A) / Max Input Power (W)		14.7 / 3.28k				
Starting Current (A)		9.80				

Model			Indoor	CS-Z71YKEA	
			Outdoor	CU-Z71YKEA	
Compressor	Type			Hermetic Motor / Rotary	
	Motor Type			Brushless (6-pole)	
	Output Power		W	1.50k	
Indoor Fan	Type			Cross-flow fan	
	Material			ASG30	
	Motor Type			DC (8-pole)	
	Input Power		W	80.2	
	Output Power		W	40	
	Speed	QLo	Cool	rpm	830
			Heat	rpm	840
		Lo	Cool	rpm	930
			Heat	rpm	920
		Me	Cool	rpm	1070
			Heat	rpm	1080
		Hi	Cool	rpm	1200
			Heat	rpm	1250
SHi	Cool	rpm	1250		
	Heat	rpm	1330		
Outdoor Fan	Type			Propeller Fan	
	Material			PP	
	Motor Type			DC (8-pole)	
	Input Power		W	-	
	Output Power		W	40	
	Speed	Hi	Cool	rpm	820
Heat			rpm	840	
Moisture Removal			L/h (Pt/h)	4.1 (8.7)	
Indoor Airflow	QLo	Cool	m <sup>3</sup> /min (ft <sup>3</sup> /min)	12.35 (436)	
		Heat	m <sup>3</sup> /min (ft <sup>3</sup> /min)	12.53 (442)	
	Lo	Cool	m <sup>3</sup> /min (ft <sup>3</sup> /min)	14.15 (500)	
		Heat	m <sup>3</sup> /min (ft <sup>3</sup> /min)	13.97 (493)	
	Me	Cool	m <sup>3</sup> /min (ft <sup>3</sup> /min)	16.66 (588)	
		Heat	m <sup>3</sup> /min (ft <sup>3</sup> /min)	16.84 (595)	
	Hi	Cool	m <sup>3</sup> /min (ft <sup>3</sup> /min)	19.00 (670)	
		Heat	m <sup>3</sup> /min (ft <sup>3</sup> /min)	19.90 (700)	
SHi	Cool	m <sup>3</sup> /min (ft <sup>3</sup> /min)	19.90 (703)		
	Heat	m <sup>3</sup> /min (ft <sup>3</sup> /min)	21.34 (754)		
Outdoor Airflow	Hi	Cool	m <sup>3</sup> /min (ft <sup>3</sup> /min)	44.7 (1580)	
		Heat	m <sup>3</sup> /min (ft <sup>3</sup> /min)	45.8 (1615)	
Refrigerant Cycle	Control Device			Expansion Valve	
	Refrigerant Oil		cm <sup>3</sup>	FW50S (600)	
	Refrigerant Type		kg (oz)	R32, 1.35 (47.7)	
F-Gas	GWP			675	
	CO <sub>2</sub> eq (ton) (Precharge Amount / Maximum Charged Amount)			0.91 / 1.25	

Model			Indoor	CS-Z71YKEA	
			Outdoor	CU-Z71YKEA	
Dimension	Unit	Height (ID / OD)	mm (inch)	295 (11-5/8) / 695 (27-3/8)	
		Width (ID / OD)	mm (inch)	1040 (40-31/32) / 875 (34-15/32)	
		Depth (ID / OD)	mm (inch)	244 (9-5/8) / 320 (12-5/8)	
Weight	Net (I/D / O/D)		kg (lb)	13 (29) / 45 (99)	
Piping	Pipe Diameter (Liquid / Gas)		mm (inch)	6.35 (1/4) / 15.88 (5/8)	
	Standard Length		m (ft)	5.0 (16.4)	
	Length Range (min - max)		m (ft)	3 (9.8) ~ 30 (98.4)	
	I/D & O/D Height Different		m (ft)	20.0 (65.6)	
	Additional Gas Amount		g/m (oz/ft)	25 (0.3)	
	Length for Additional Gas		m (ft)	10 (32.8)	
Drain Hose	Inner Diameter		mm	16.7	
	Length		mm	650	
Indoor Heat Exchanger	Fin Material			Aluminium (Pre coat)	
	Fin Type			Slit Fin	
	Row x Stage x FPI			2 x 17 x 21	
	Size (W x H x L)		mm	814.5 x 357 x 25.4	
Outdoor Heat Exchanger	Fin Material			Aluminium (Pre coat)	
	Fin Type			Corrugated Fin	
	Row x Stage x FPI			2 x 31 x 19	
	Size (W x H x L)		mm	36.4 x 651 x 904.5:874.5	
Air Filter	Material			Polypropelene	
	Type			One-touch	
Power Supply				Indoor	
Power Supply Cord				NIL	
Thermostat				Electronic Control	
Protection Device				Electronic Control	
				Dry Bulb	Wet Bulb
Indoor Operation Range	Cooling	Maximum °C (°F)		32 (89.6)	23 (73.4)
		Minimum °C (°F)		16 (60.8)	11 (51.8)
	Heating	Maximum °C (°F)		30 (86.0)	-
		Minimum °C (°F)		16 (60.8)	-
Outdoor Operation Range	Cooling	Maximum °C (°F)		43 (109.4)	26 (78.8)
		Minimum °C (°F)		-25 (-13.0)	-
	Heating	Maximum °C (°F)		24 (75.2)	18 (64.4)
		Minimum °C (°F)		-15 (5.0)	-

- Cooling capacities are based on indoor temperature of 27°C Dry Bulb (80.6°F Dry Bulb), 19.0°C Wet Bulb (66.2°F Wet Bulb) and outdoor air temperature of 35°C DRY BULB (95°F Dry Bulb), 24°C Wet Bulb (75.2°F Wet Bulb).
- Heating capacities are based on indoor temperature of 20°C Dry Bulb (68°F Dry Bulb) and outdoor air temperature of 7°C Dry Bulb (44.6°F Dry Bulb), 6°C Wet Bulb (42.8°F Wet Bulb).
- Network Impedance shall be applicable for Europe models only.
- The annual consumption is calculated by multiplying the input power by an average of 500 hours per year in cooling mode.
- EER and COP Class: Refer Att 11, RAD-A-04-06, eg. Europe: classification is at 230V only in accordance with EU directive 2003/31/EC, A – G, Australia: n star, Singapore: Tick n, etc.
- Heating low temperature capacity, Input Power and COP measured at 230 V, indoor temperature 20°C, outdoor 2/1°C.
- Heating extreme low temperature capacity, Input Power and COP measured at 230 V, indoor temperature 20°C, outdoor -7/-8°C.
- Standby power consumption ≤2.0W (when switched OFF by remote control, except under self protection control).
- Specifications are subjected to change without prior notice for further improvement.
- SEER and SCOP classification is at 230V only in accordance with EN-14825. For heating, SCOP indicates the value of only Average heating season.

## 4. Features

- **Inverter Technology**
  - Wider output power range
  - Energy saving
  - Quick Cooling
  - Quick Heating
  - More precise temperature control
- **Environment Protection**
  - Non-ozone depletion substances refrigerant (R32)
- **Long Installation Piping**
  - Long piping up to 20 meter (Z25/35/42YKEA), 30 meters (Z50/70YKEA) meters during single split connection only
- **Easy to use remote control**
- **Quality Improvement**
  - Random auto restart after power failure for safety restart operation
  - Gas leakage protection
  - Prevent compressor reverse cycle
  - Inner protector to protect compressor
  - Noise prevention during soft dry operation
- **Operation Improvement**
  - Quiet mode to reduce the indoor unit operating sound
  - Powerful mode to reach the desired room temperature quickly
  - 24-hour timer setting
- **Serviceability Feature**
  - Breakdown Self Diagnosis function
- **Communications network**

## 5. Location of Controls and Components

### 5.1 Indoor Unit

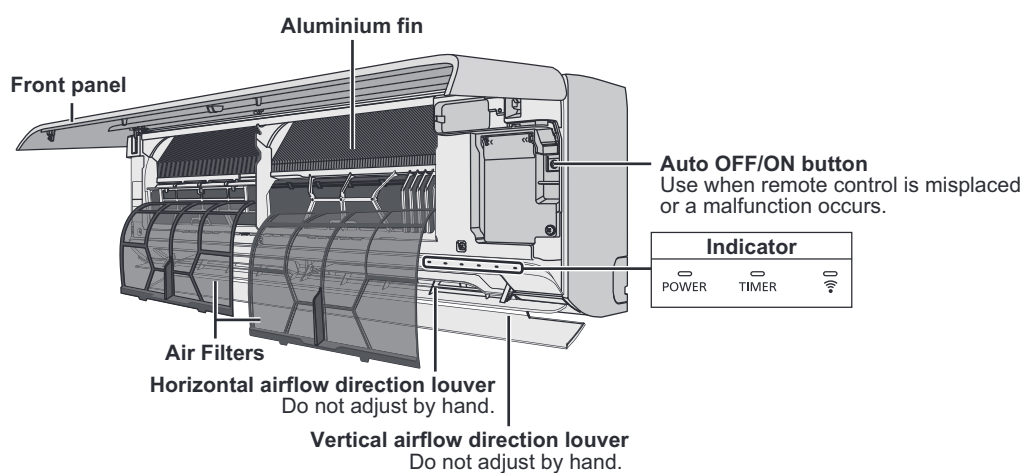

### 5.2 Outdoor Unit

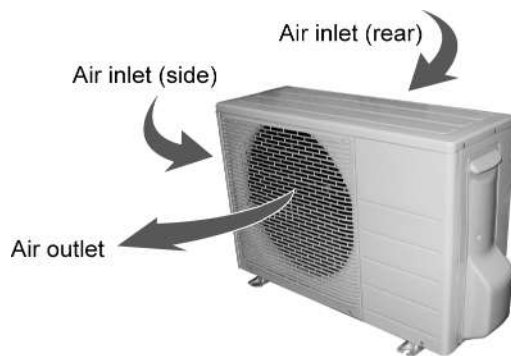

## 5.3 Remote Control

### 5.3.1 Remote Controller Buttons and Display

Buttons / Indicator	
①	<b>Quick Menu button</b>
②	<b>Back button</b> Returns to the previous screen
③	<b>LCD Display</b>
④	<b>Main Menu button</b> For function setup
⑤	<b>ON/OFF button</b> Starts/Stops operation
⑥	<b>Operation indicator</b> Illuminates during operation, blinks during alarm.

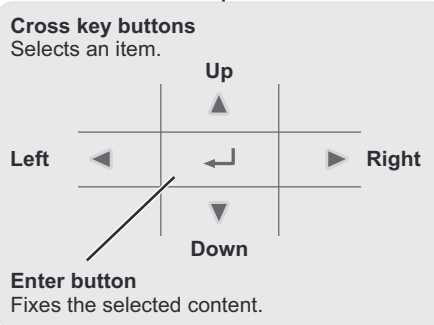
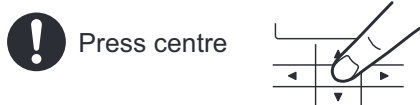
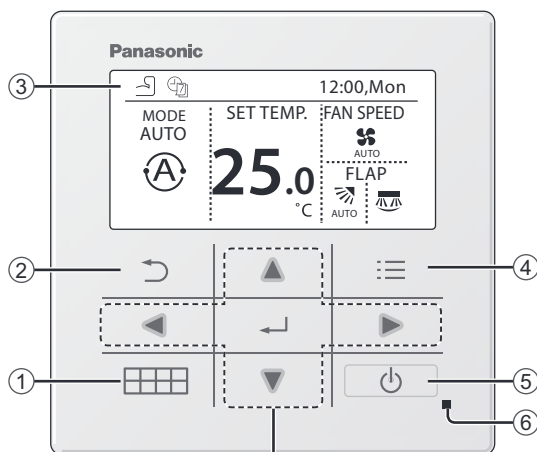

## 5.3.2 Initialization

Please initiate the Remote Control by selecting the language of operation and set the date and time accordingly before setting up the operation menu preferences. During first power ON, Remote Controller will automatically prompt setting screen as default. It can also be access from Personal Setup in the Main Menu.

### Selecting the language

Wait while the display is initializing.  
When initializing screen ends, it turns to normal screen.  
When any button is pressed, language setting screen appears.

- ① Scroll with ▼ and ▲ to select the language.
- ② Press ← to confirm the selection.

### Setting the clock

- ① Select with ▼ or ▲ to display the time, either 24h or am/pm format (for example, 15:00 or 3:00 pm).
- ② Press ← to confirm the selection.
- ③ Use ▼ and ▲ to select year, month, day, hour and minutes. (Select and move with ► and press ← to confirm.)
- ④ Once the time is set, time and day will appear on the display even if the Remote Controller is turned OFF.

### Setting the temperature unit

- ① Scroll with ▼ and ▲ to select the unit.

### Selecting the Heat mode

- ① Scroll with ▼ and ▲ to select Enable or Disable.

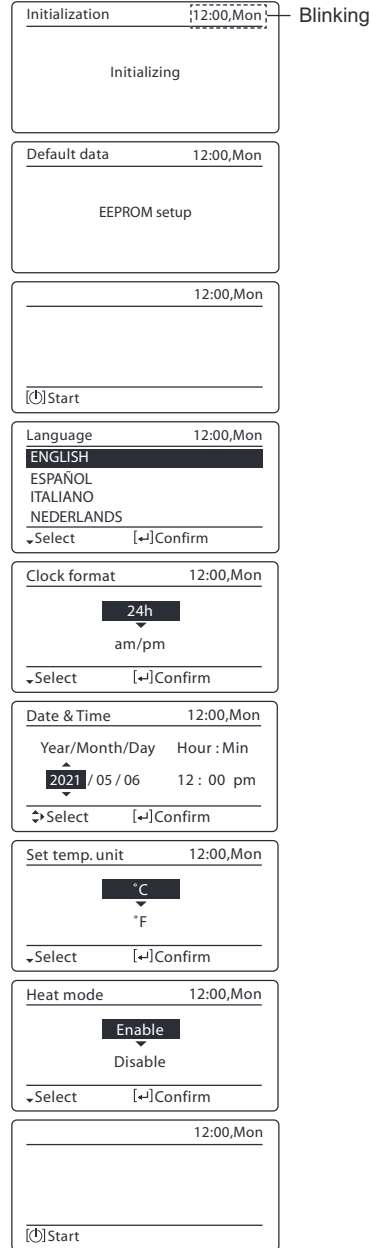





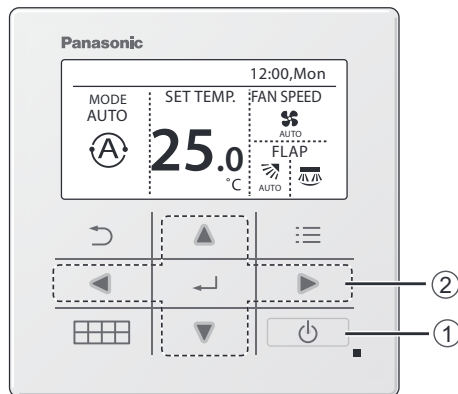

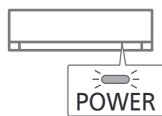

### 5.3.3 Quick Guide

#### 5.3.3.1 Basic Operation



- ① Press  to start/stop the operation.



- ② Press     to select either mode, set temperature, fan speed or air swing section.
- Use  or  to select setting.
  - Press  to confirm the selection.

#### Mode section

Default setting for Mode is Auto.



#### Set temperature section

Selection range:  
16.0 °C ~ 30.0 °C / 60 °F ~ 86 °F.

#### Fan speed section

- When FAN AUTO is selected, the fan speed is adjusted automatically according to the operation mode.
- Select the lowest fan speed to have a low noise operation.



#### Air swing section

- Do not adjust the flap by hand.
- \* For details operation, refer "To Learn More..."

#### Up/Down Air Swing







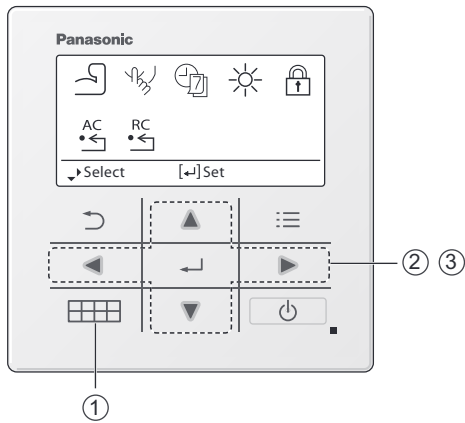

#### Left/Right Air Swing



## 5.3.4 Quick Menu



- ① Press .
- ② Use     to select quick menu.
- ③ Press  to turn on/off the select mode.

To return to the Main Screen, Press  or .

### Quick Menu

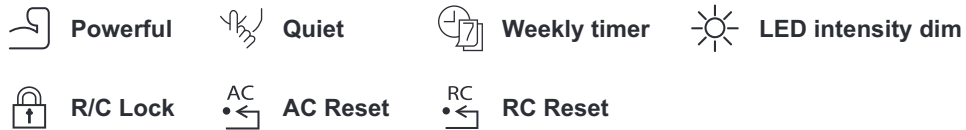

Select each setting and confirm the setting according to the instructions displayed at the bottom of the screen. (The icons refer to each selection key.)

#### Powerful \*1

Select this icon to operate Powerful mode.

Press  to confirm your selection.

When Powerful mode is selected, an icon will appear on top left of Main Screen.

\* Refer to "Remote Controller buttons and display"

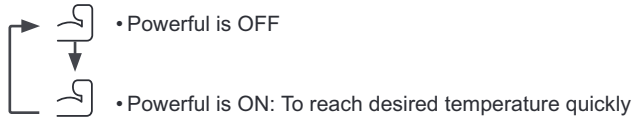

#### Note:

Powerful is automatically stop after 20 minutes.

Powerful will be disabled in below conditions:-

- when fan speed is changed,
- when Quiet is enabled.

\*1 Not available when 'Duty rotation' is turned on.

## Quiet \*1

Select this icon to enjoy quiet operation. Quiet mode reduces airflow noise.

**Press**  **to confirm your selection.**

When Quiet mode is selected, an icon will appear on top left of Main Screen.

\* Refer to "Remote Controller buttons and display"

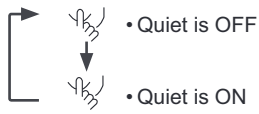

### Note:

Quiet is disabled when fan speed is changed or Powerful is enabled.

## Weekly timer \*1

Select this icon to delete (cancel) or change the pre-set Weekly Timer.

**Press**  **to confirm your selection.**

When Weekly Timer mode is selected, an icon will appear on top left of Main Screen.

\* Refer to "Remote Controller buttons and display"

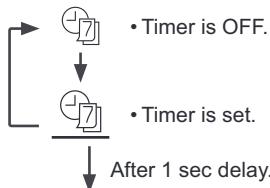

Do you want to edit Weekly timer pattern?

Yes  No

### Select "Yes".

• If you select "No", the screen will return to the Quick Menu Screen.

Timer setup

Timer copy

- Timer setup: Select Timer setup to edit the Weekly Timer.
- Timer copy: Select to copy a timer setting.





Sun	Mon	Tue	Wed	Thu	Fri	Sat
✓	✓	✓	✓	✓	✓	✓

### [Example of a Timer setup]

Select the day(s) which you wish to edit using ▲ ▼ buttons.

Weekly timer 12:00, Mon

Sun	Mon	Tue	Wed	Thu	Fri	Sat
1.	6:00am	ON	⊗	25.0°C		
2.	8:00am	ON	⊗	25.0°C		
3.	10:00am	ON	⊗	25.0°C		
①	②	③	④	⑤		

- ① Select pattern "1" ~ "6".
  - ② Set the hour and minutes of the Timer.
  - ③ Select ON/OFF of the Timer.
  - ④ Select the operation mode.
  - ⑤ Set the temperature.
-  /  /  / 

All 6 patterns are not set!  
Do you want to edit?

Yes  No

If all 6 patterns are not set in a day, this screen will be displayed.

### Note:

If all entries are found to be reset to default, this could be due to 'Heat mode' setting is disable.

\*1 Not available when 'Duty rotation' is turned on.

## LED intensity dim \*1

Select this icon to dim or restore the indicators' brightness on the unit.

## R/C Lock

Select this icon to lock the Remote Controller.

**Press  to confirm your selection.**

(When the mode has been accepted, below screen will be displayed.)

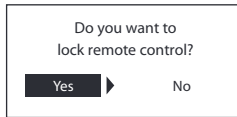

**Select "Yes".**

(The Main Screen will be locked.)





• If "No" is selected, the screen will return to the Quick Menu Screen.

### To unlock the Remote Controller

**Press any key.**

(When the mode has been accepted, below screen will be displayed.)





Press  or  to scroll and choose the digits. Press  or  to move to adjacent digit. Press  to confirm the four-digit code. (if the number is correct, the screen will be unlocked).

### To reset forgotten password

**Press ,  and  continuously for 5 seconds.**

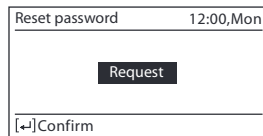
(When the mode has been accepted, below screen will be displayed.)



Press .

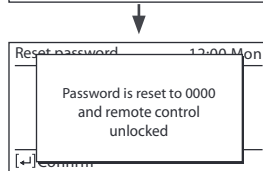

Password will be reset after 3 seconds.  
Main screen will be unlocked.

## AC Reset \*1

Select this icon to reset the air conditioner and turn it off.

## RC Reset

Select this icon to reset the remote controller and perform initialization again.

\*1 Not available when 'Duty rotation' is turned on.

## 5.3.5 Main Menu

Select menus and determine settings according to the system available in the household.

- After initial installation, you may manually adjust the settings.
- The initial setting remains active until the user changes it.
- The Remote Controller can be used for multiple installations.
- The system may not work properly if set wrongly. Please consult an authorised dealer.

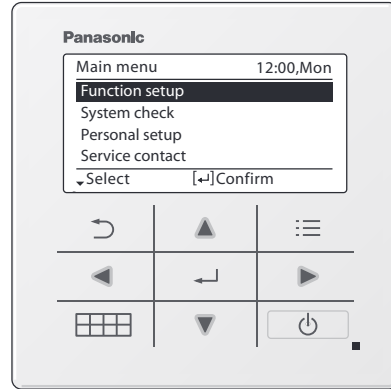

To display <Main menu>: ☰

To select content: ▲▼◀▶

To confirm the selected content: ↵

Press ☰ to return to main screen

Menu	Default Setting	Setting Options / Display
<b>1 Function setup</b>		
<b>1.1 &gt; Model type</b> <sup>*1/*2</sup>		
To select model type.	Wall mounted	Model type 12:00,Mon Wall mounted (highlighted) Floor console Cassette Ducted ↓Select [+/-]Confirm
<b>1.2 &gt; Heat mode</b> <sup>*1/*2/*3</sup>		
To enable or disable heat mode.	Enable	Enable (highlighted) Disable
<b>1.3 &gt; Left/Right swing</b> <sup>*1/*2</sup>		
To enable or disable left/right swing.	Enable	Enable (highlighted) Disable
<b>1.4 &gt; Powerful</b> <sup>*1/*2</sup>		
To enable or disable powerful mode.	Enable	Enable (highlighted) Disable
<b>1.5 &gt; Quiet</b> <sup>*1/*2</sup>		
To enable or disable quiet mode.	Enable	Enable (highlighted) Disable

\*1 Not available when 'Duty rotation' is turned on.



\*2 This function will become hidden when unit is turned on.

\*3 'Heat mode' becomes hidden when 'Weekly timer' is activated and has entries with heat mode inside.

Menu	Default Setting	Setting Options / Display
<b>1.6 &gt; Filter check</b> *1		
To enable or disable filter check reset option in Quick Menu.	Disable	Enable Disable
<b>1.7 &gt; WLAN</b> *1		
To apply the WLAN settings in Panasonic Comfort Cloud phone app. * Please refer to Setup Instructions Manual.	WLAN ON/OFF Easy Setting (WPS) Advance setting (AP) Device registration WLAN strength WLAN initialization Learning reset	WLAN 12:00,Mon WLAN ON/OFF Easy setting (WPS) Advance setting (AP) Device registration ↓Select    [+] Confirm Request
<b>1.8 Duty rotation</b>		
* Only applicable if 2 indoor units are connected through optional part, Part No. CZ-RCC5 or equivalent.		
<b>1.8.1 &gt; Rotation ON/OFF</b>		
To set the rotation ON or OFF.	OFF	Duty rotation 12:00,Mon Rotation ON/OFF Rotation interval Rotation status ↓Select    [+] Confirm
<b>1.8.2 &gt; Rotation interval</b>		
To set the rotation interval range. Interval range: 1h ~ 23h	12h	Rotation 12:00,Mon Interval Range: (1h~23h)    12 Step: ±1h ↕Select    [+] Confirm
<b>1.8.3 &gt; Rotation status</b>		
To view the rotation status of unit.	Select and retrieve	Status 12:00,Mon Main unit comm. : Sub unit comm. : Main unit : Sub unit : ↓Page 2    [+] Close
<b>1.9 &gt; Diagnosis</b> *1		
To enable operations in the indoor unit AUTO OFF/ON switch.	Select and retrieve	Request

\*1 Not available when 'Duty rotation' is turned on.

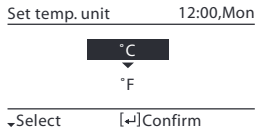
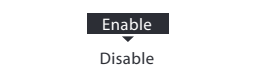
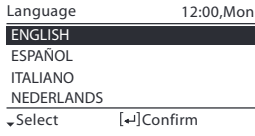
Menu	Default Setting	Setting Options / Display
<b>2 System check</b>		
To perform failure diagnosis. If the Error code matches with the error encountered, you will hear a beeping sound. * Please refer to "Troubleshooting" for error codes.	Select and retrieve	System check 12:00,Mon H00 No memory of failure
<b>3 Personal setup</b>		
<b>3.1 &gt; Touch sound</b>		
To enable or disable the operation sound.	Enable	Enable Disable
<b>3.2 &gt; LCD contrast</b>		
To set the screen contrast.	3	LCD contrast 12:00,Mon Low High Select [↔]Confirm
<b>3.3 &gt; Backlight</b>		
To set the duration of screen backlight.	1 min	Backlight 12:00,Mon OFF 5 mins 15 secs 10 mins 1 min Select [↔]Confirm
<b>3.4 &gt; Backlight intensity</b>		
To set the screen backlight brightness.	4	Backlight intensity 12:00,Mon Dark Bright Select [↔]Confirm
<b>3.5 &gt; Clock format</b>		
To set the type of clock display format.	24h	Clock format 12:00,Mon 24h am/pm Select [↔]Confirm
<b>3.6 &gt; Date &amp; Time</b>		
To set the present date and time.	Year / Month / Day / Hour / Min	Date & Time 12:00,Mon Year/Month/Day Hour : Min 2021 / 01 / 01 12 : 00 pm Select [↔]Confirm

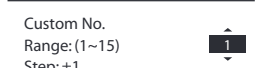
Menu	Default Setting	Setting Options / Display
<b>3.7 &gt; Set temp. unit</b>		
To set the temperature unit.	°C	Set temp. unit 12:00, Mon  ↓Select [↵]Confirm
<b>3.8 &gt; Set temp. decimal</b>		
To set the temperature decimal unit.	Enable	 ↓Select [↵]Confirm
<b>3.9 &gt; Language</b>		
Sets the display language for the top screen. • For Greek and Bulgarian, please refer to the English version	ENGLISH / ESPAÑOL / ITALIANO / NEDERLANDS / PORTUGUÊS / FRANÇAIS / DEUTSCH / HRVATSKI / TÜRKÇE / SWEDISH / NORWEGIAN / DANISH / SUOMI / MAGYAR	Language 12:00, Mon  ↓Select [↵]Confirm
<b>3.10 &gt; Unlock password</b>		
4 digit password for all the settings.	0000	Unlock password 12:00, Mon  ↓Select [↵]Confirm
<b>4 Service contact *1</b>		
<b>4.1 &gt; Contact 1 / Contact 2</b>		
Preset contact number for installer.	Select and retrieve	Service contact 12:00, Mon Contact 1 Name : Bryan Adams  : 08812345678 ↓Contact 2 [↵]Edit
<b>5 Custom setup *1</b>		
<b>5.1 &gt; Custom No.</b>		
Preset custom setup. Range: 1~15 * Wrong setting can affect system operations. Please consult an authorised dealer.	<b>Custom No Range Descriptions</b> 1 : Remote controller number 2 : Solar radiation sensitivity level adjustment 3 : Cool & Dry mode set temperature [Low] 4 : Cool & Dry mode set temperature [High] 5 : Heat mode set temperature [Low] 6 : Heat mode set temperature [High] 7 : Filter cleaning 8 : nanoe / nanoe-G default ON 9 : Dust sensor monitoring & LED 10 : Auto restart 11 : Dust sensor sensitivity level adjustment 12 : Auto mode set temperature [Low] 13 : Auto mode set temperature [High] 14 : Indoor unit installation position 15 : Eco status memorize	Custom setup 12:00, Mon Custom No. Range: (1~15)  Step: ±1 ↓Select [↵]Confirm

\*1 Not available when 'Duty rotation' is turned on.

# 6. Dimensions

## 6.1 Indoor Unit

### 6.1.1 CS-Z25YKEA CS-Z35YKEA CS-Z42YKEA

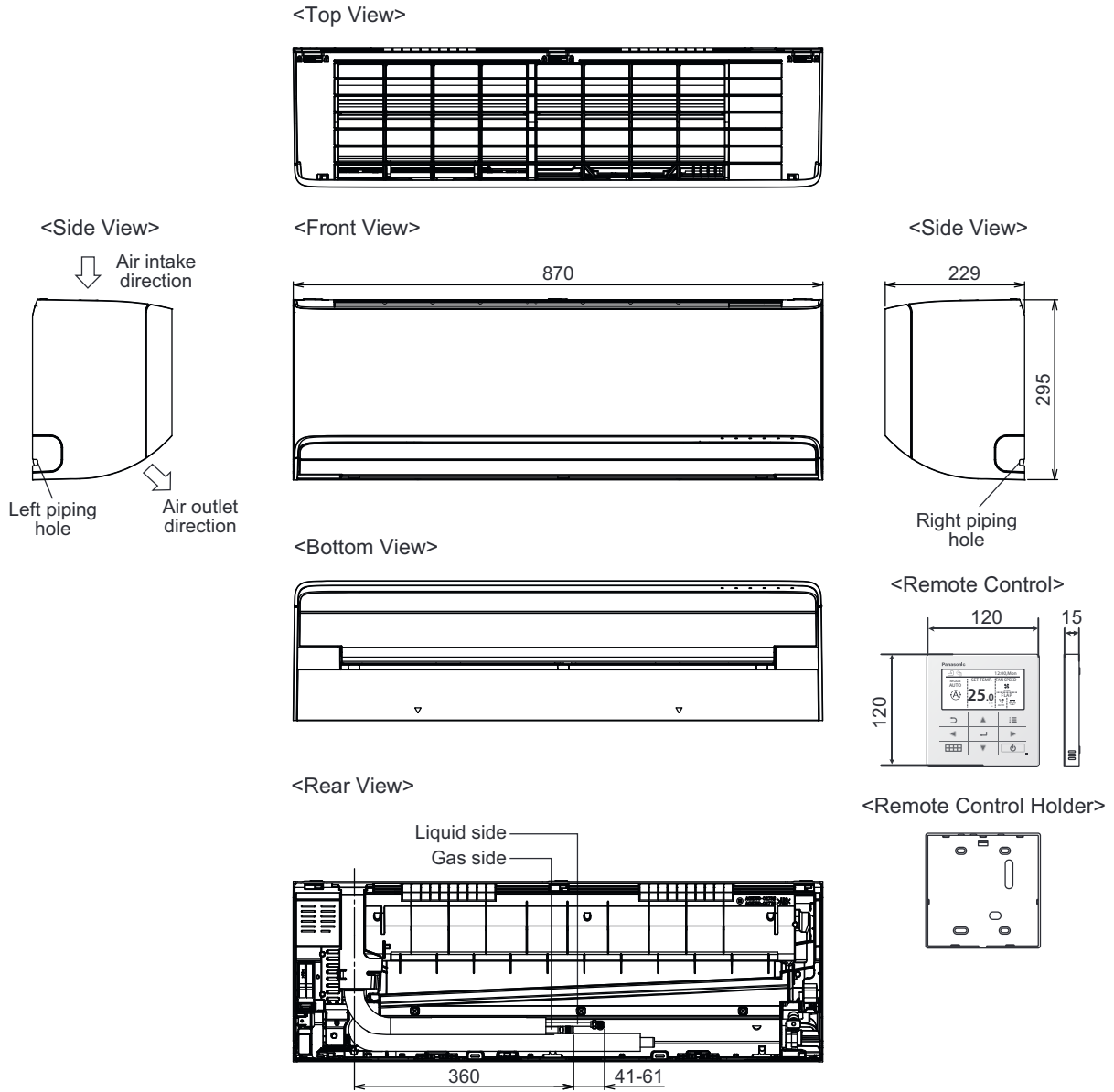

Relative position between the indoor unit and the installation plate <Front View>

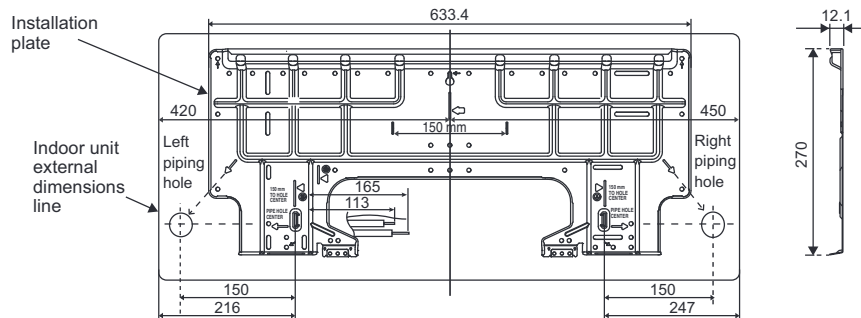

Unit: mm

## 6.1.2 CS-Z50YKEA CS-Z71YKEA

<Top View>

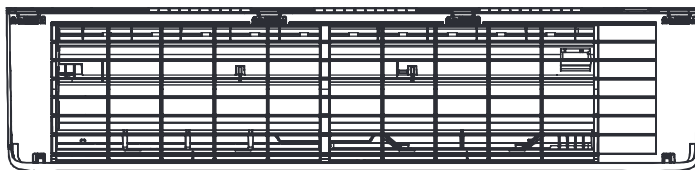

<Side View>

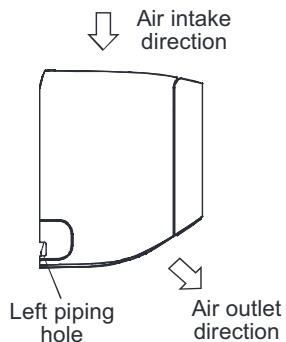

<Front View>

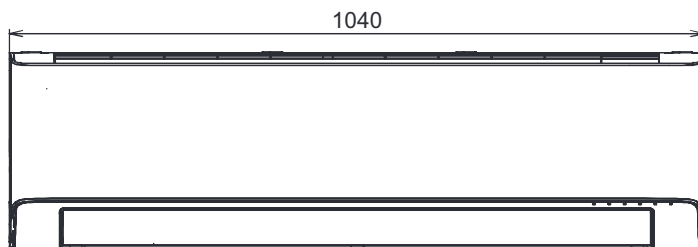

<Side View>

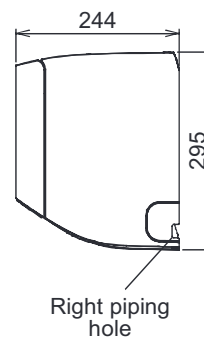

<Bottom View>

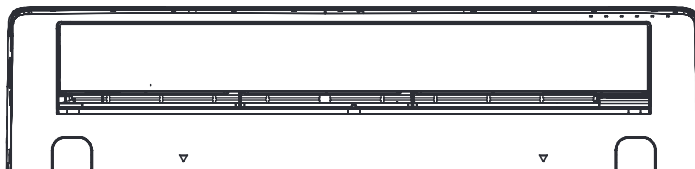

<Remote Control>

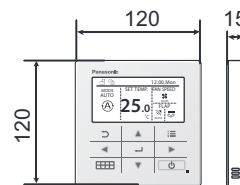

<Rear View>

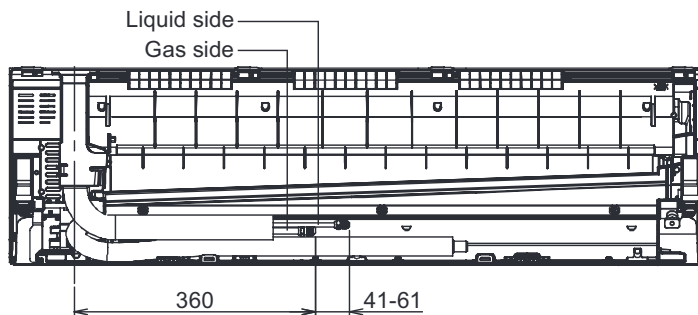

<Remote Control Holder>

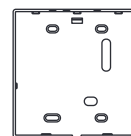

Relative position between the indoor unit and the installation plate <Front View>

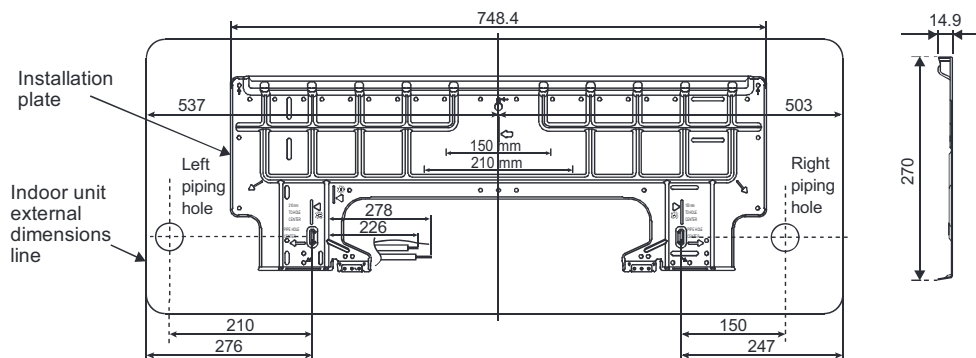

Unit: mm

## 6.2 Outdoor Unit

### 6.2.1 CU-Z25YKEA CU-Z35YKEA CU-Z42YKEA

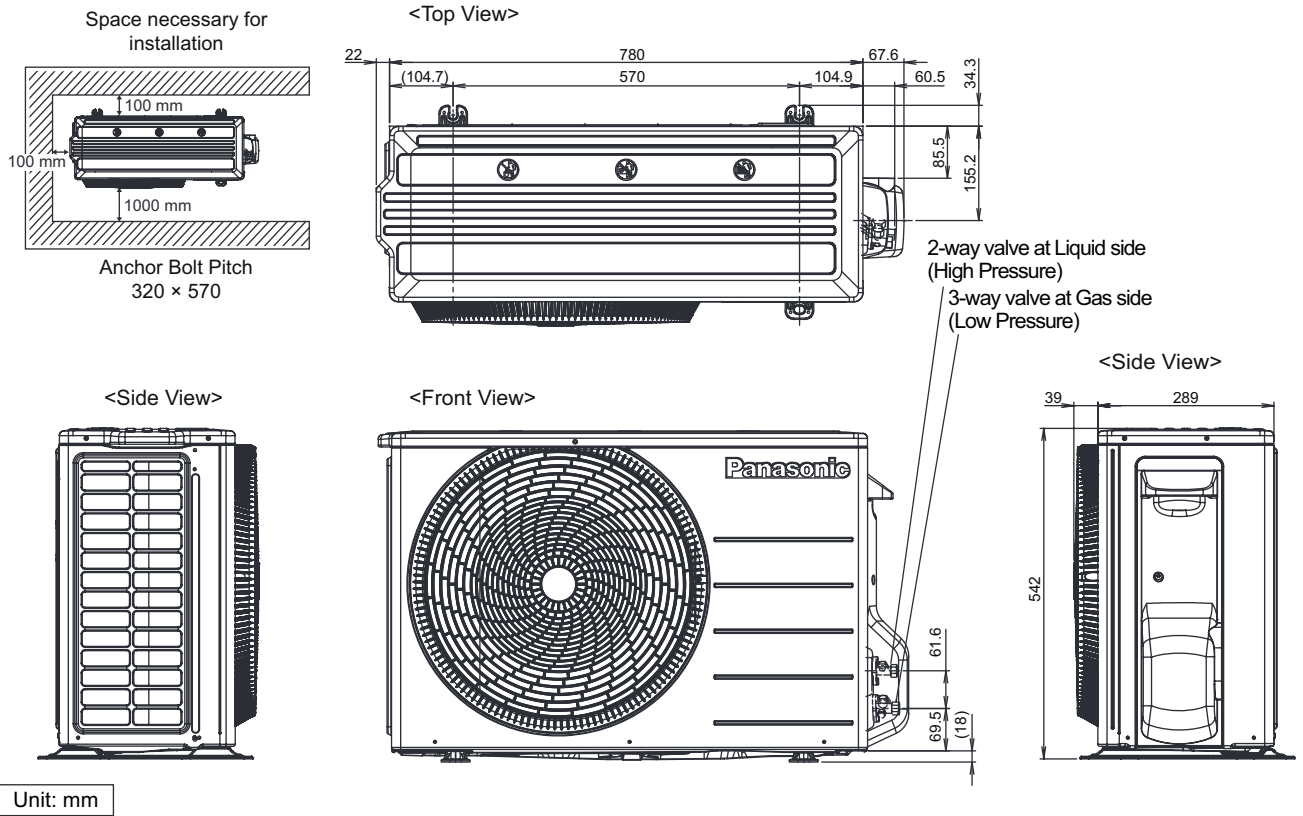

### 6.2.2 CU-Z50YKEA CU-Z71YKEA

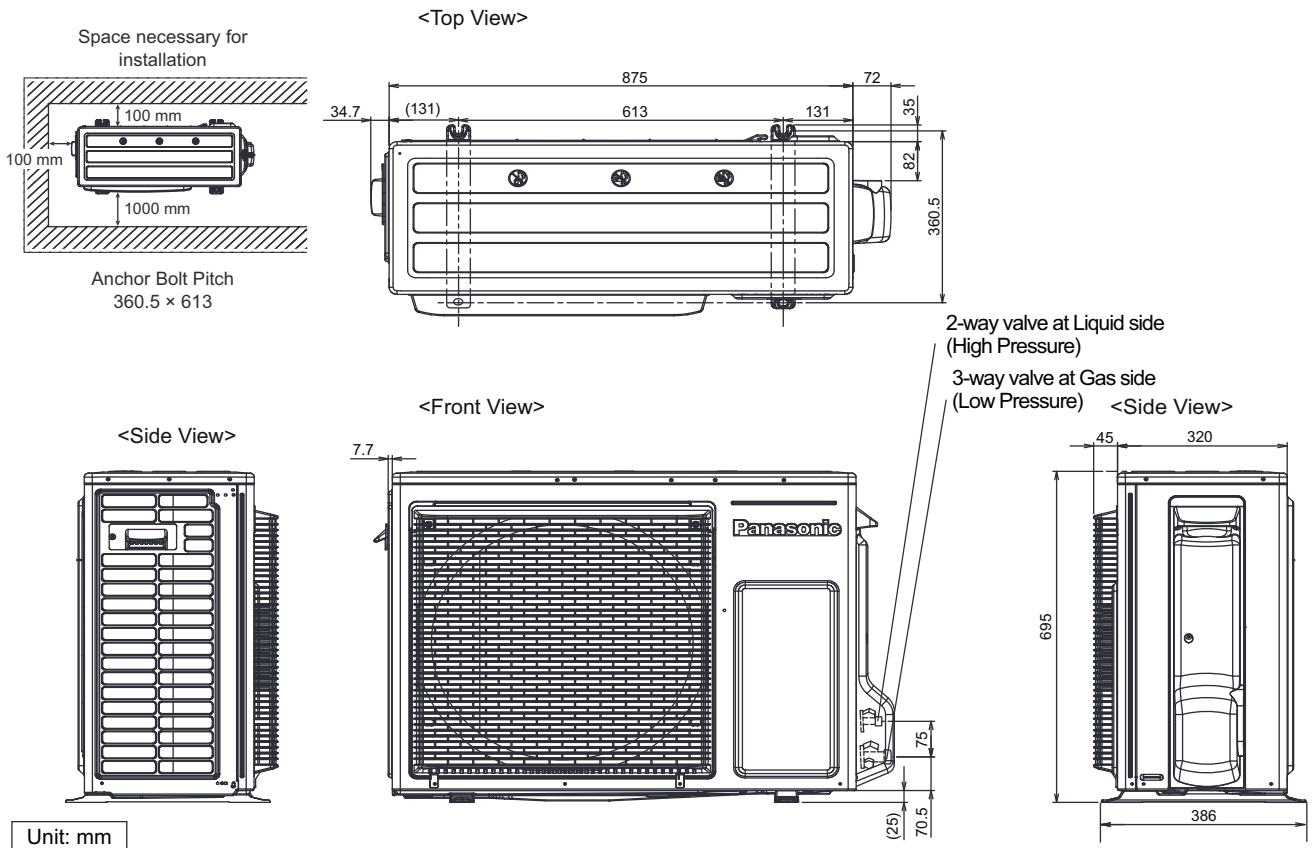

# 7. Refrigeration Cycle Diagram

## 7.1 CS-Z25YKEA CU-Z25YKEA CS-Z35YKEA CU-Z35YKEA CS-Z42YKEA CU-Z42YKEA

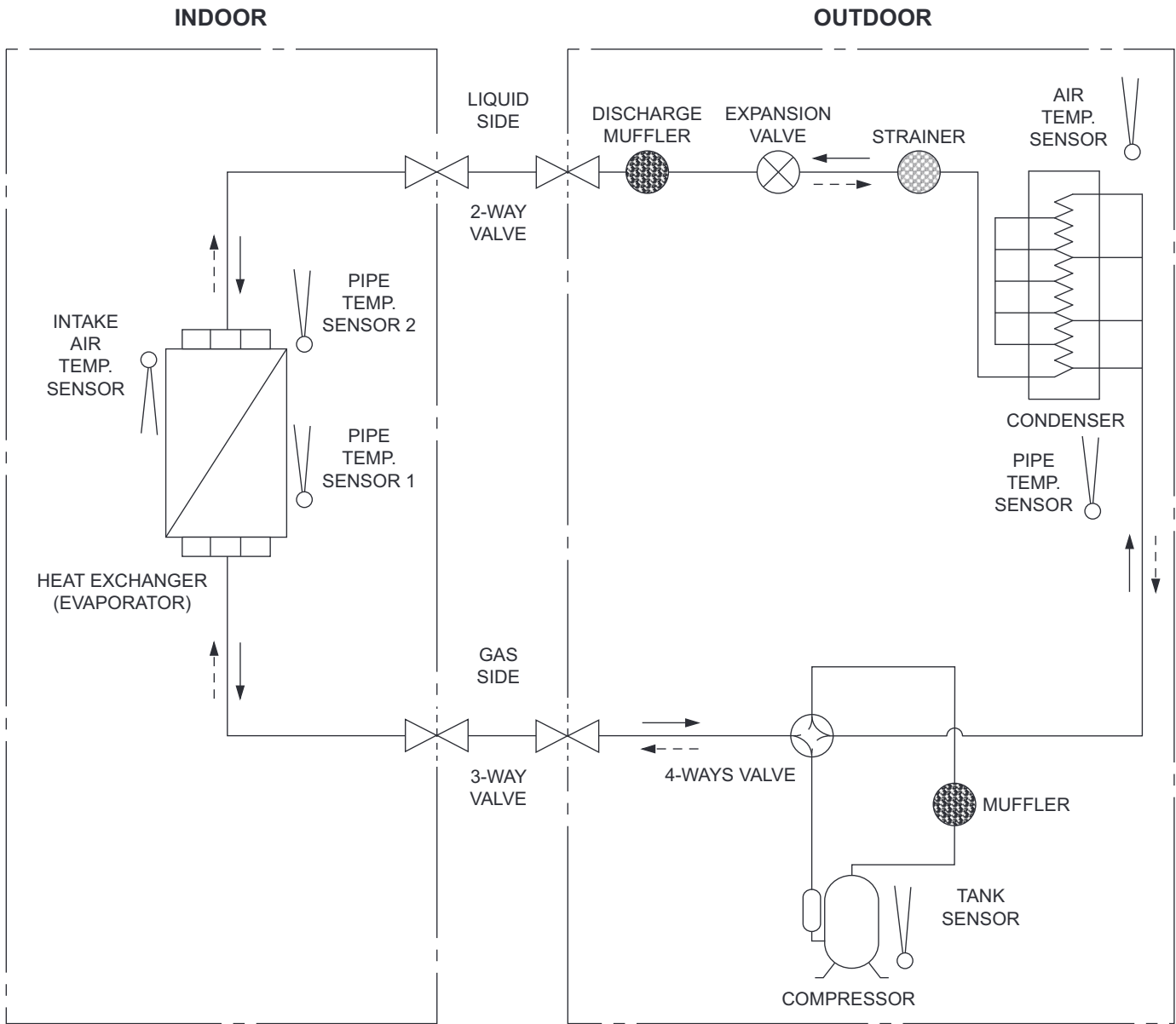

—→ COOLING  
- - -→ HEATING

## 7.2 CS-Z50YKEA CU-Z50YKEA

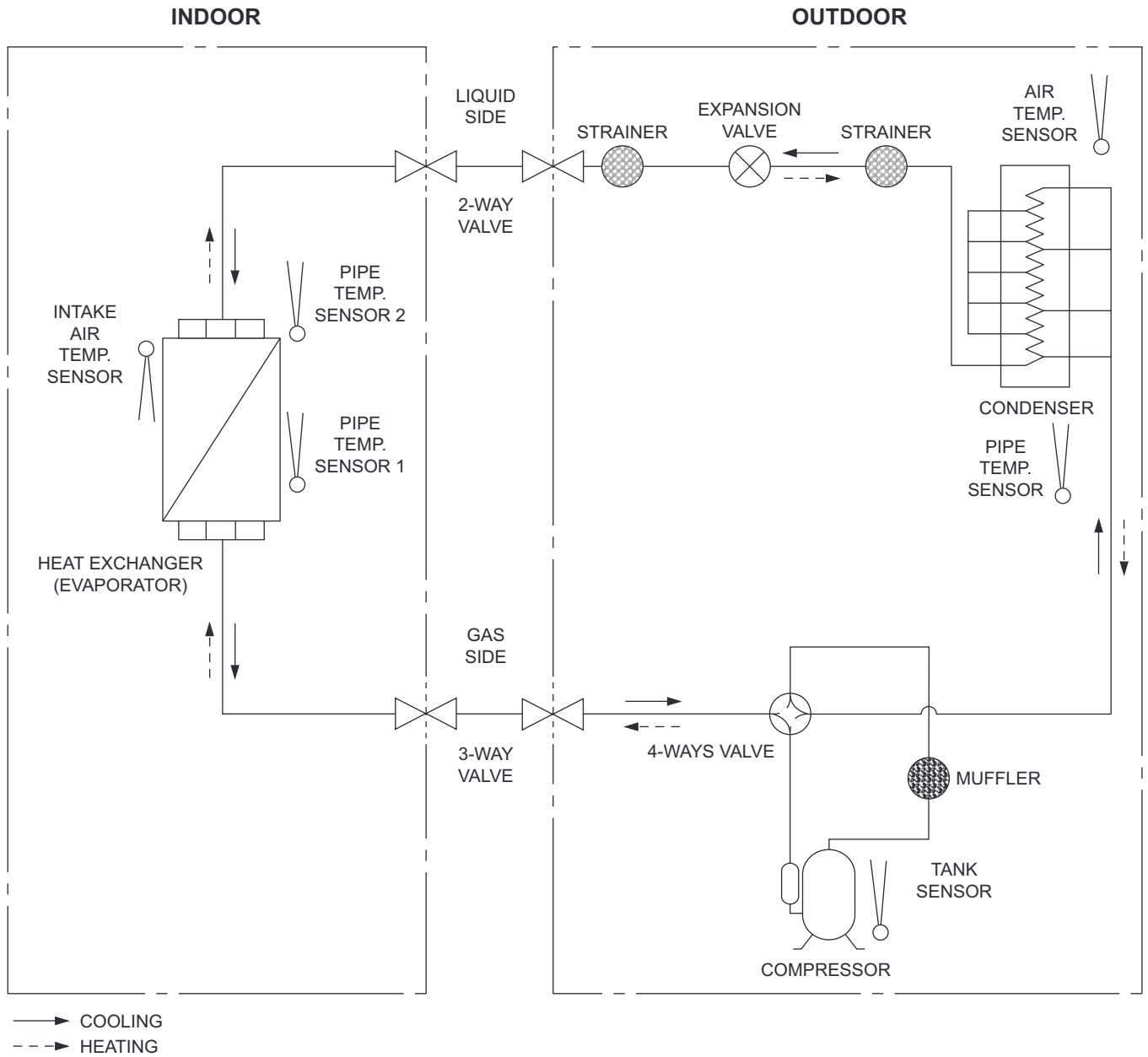

### 7.3 CS-Z71YKEA CU-Z71YKEA

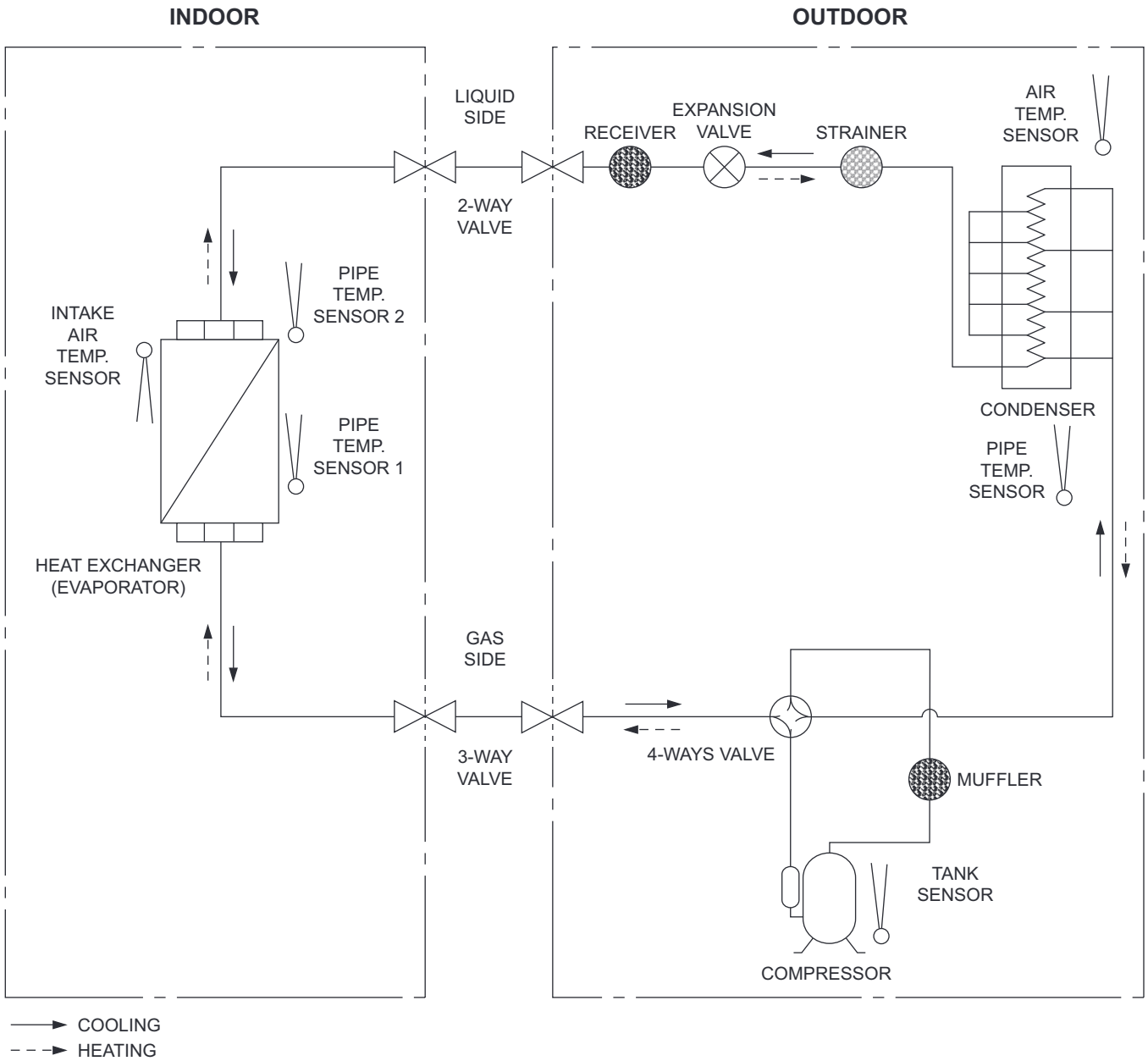

# 8. Block Diagram

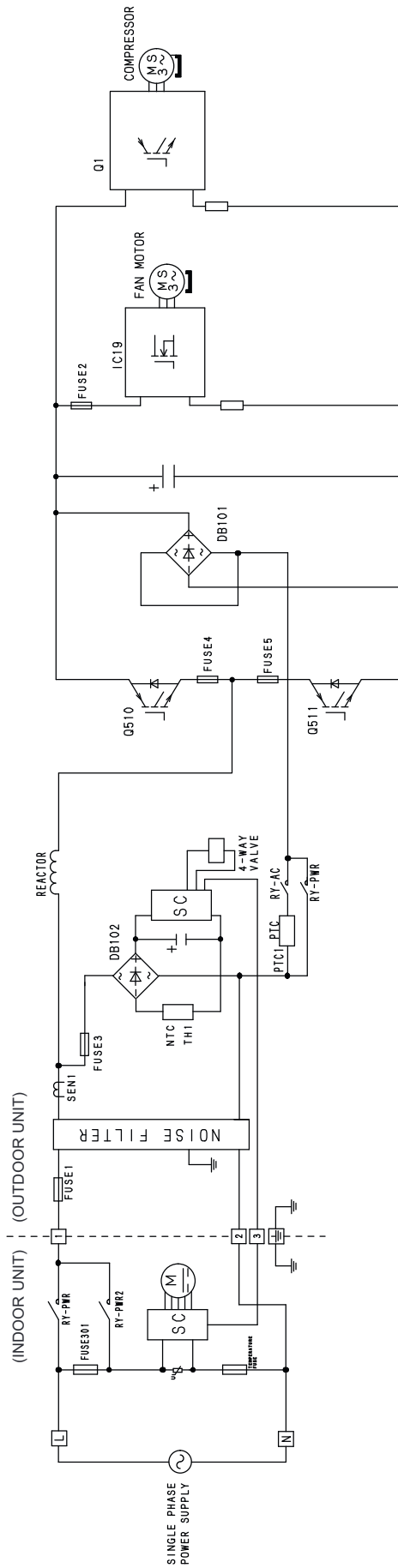

# 9. Wiring Connection Diagram

## 9.1 Indoor Unit

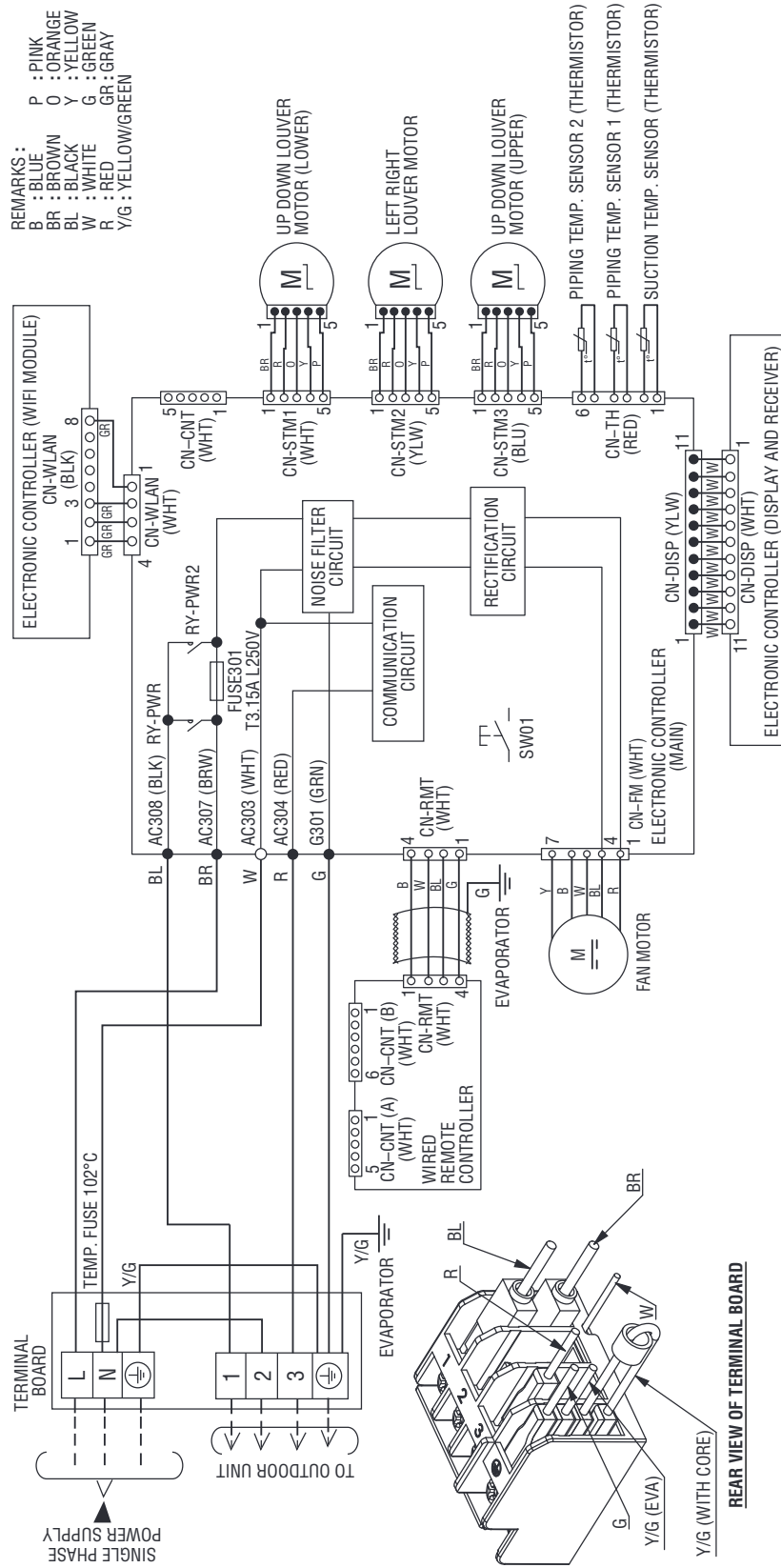

## 9.2 Outdoor Unit

### 9.2.1 CU-Z25YKEA CU-Z35YKEA CU-Z42YKEA

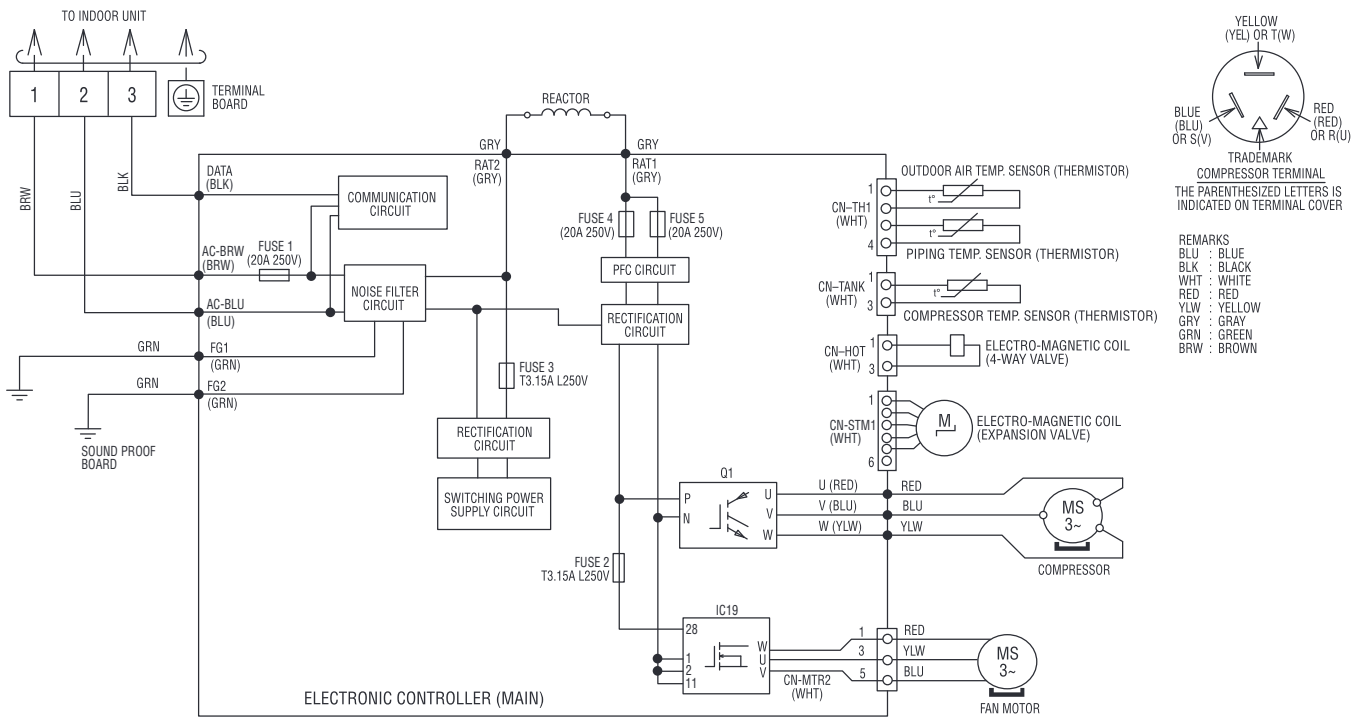

#### Resistance of Compressor Windings

MODEL	CU-Z25YKEA / CU-Z35YKEA / CU-Z42YKEA
CONNECTION	9RS102XRA21 ( $\Omega$ )
U-V	2.389
U-W	2.389
V-W	2.389

Note: Resistance at 20°C of ambient temperature.

## 9.2.2 CU-Z50YKEA CU-Z71YKEA

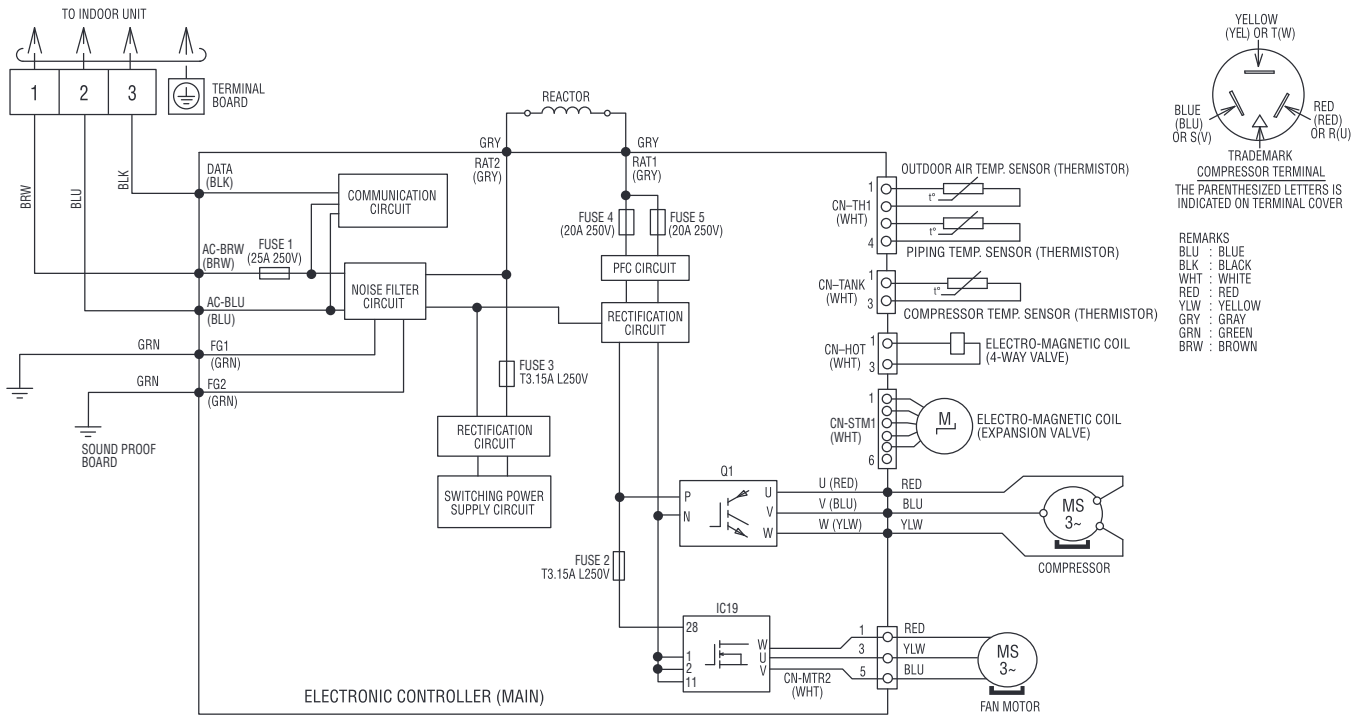

Resistance of Compressor Windings

MODEL	CU-Z50YKEA
CONNECTION	9RD132XGA21 (Ω)
U-V	1.708
U-W	1.708
V-W	1.708

Note: Resistance at 20°C of ambient temperature.

MODEL	CU-Z71YKEA
CONNECTION	9RD220XBA21 (Ω)
U-V	0.998
U-W	0.998
V-W	0.998

Note: Resistance at 20°C of ambient temperature

# 10. Electronic Circuit Diagram

## 10.1 Indoor Unit

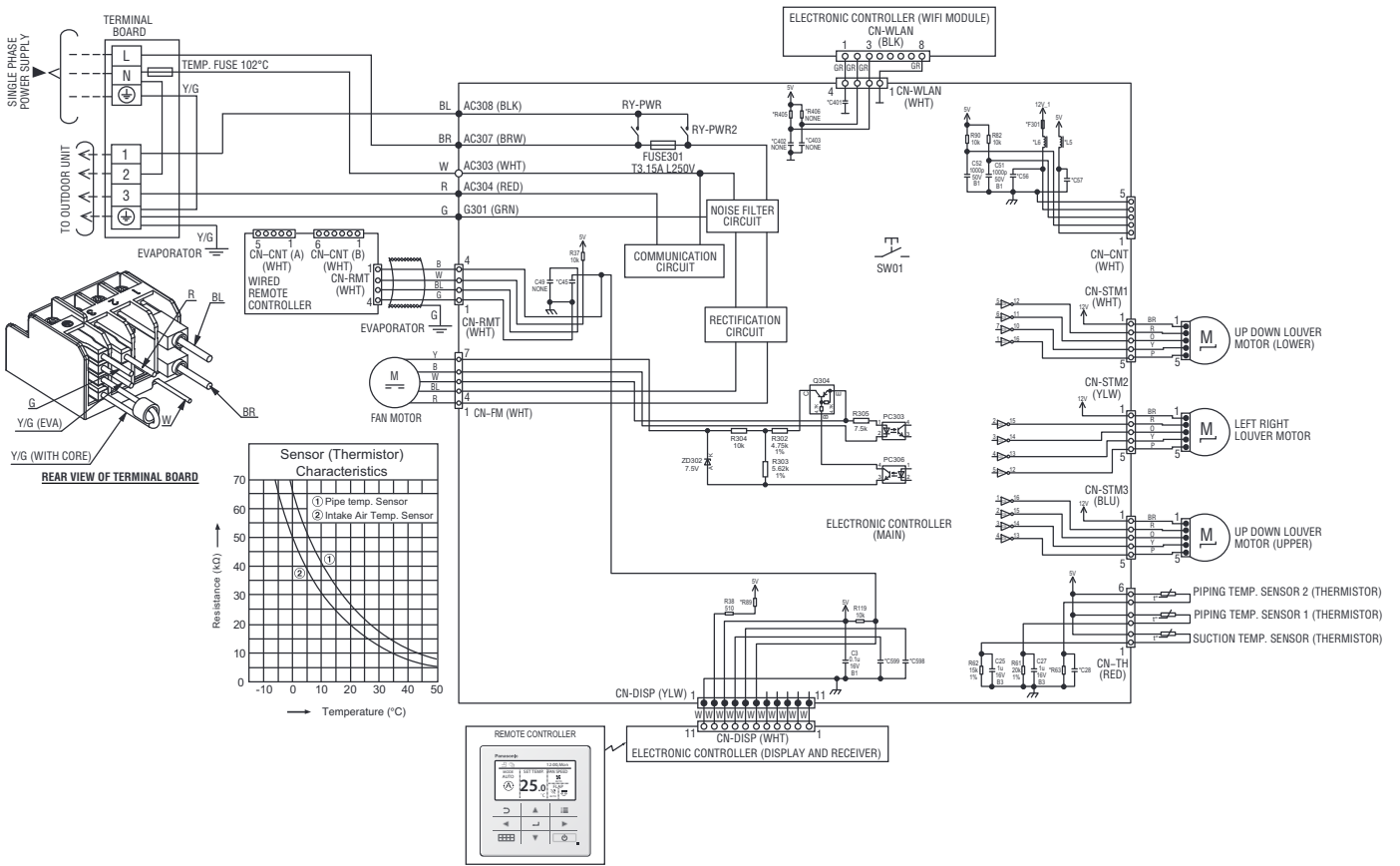

# 10.2 Outdoor Unit

## 10.2.1 CU-Z25YKEA CU-Z35YKEA CU-Z42YKEA

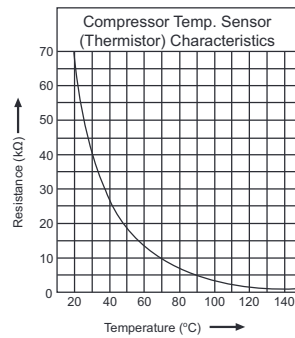
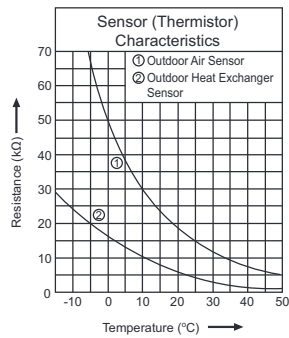
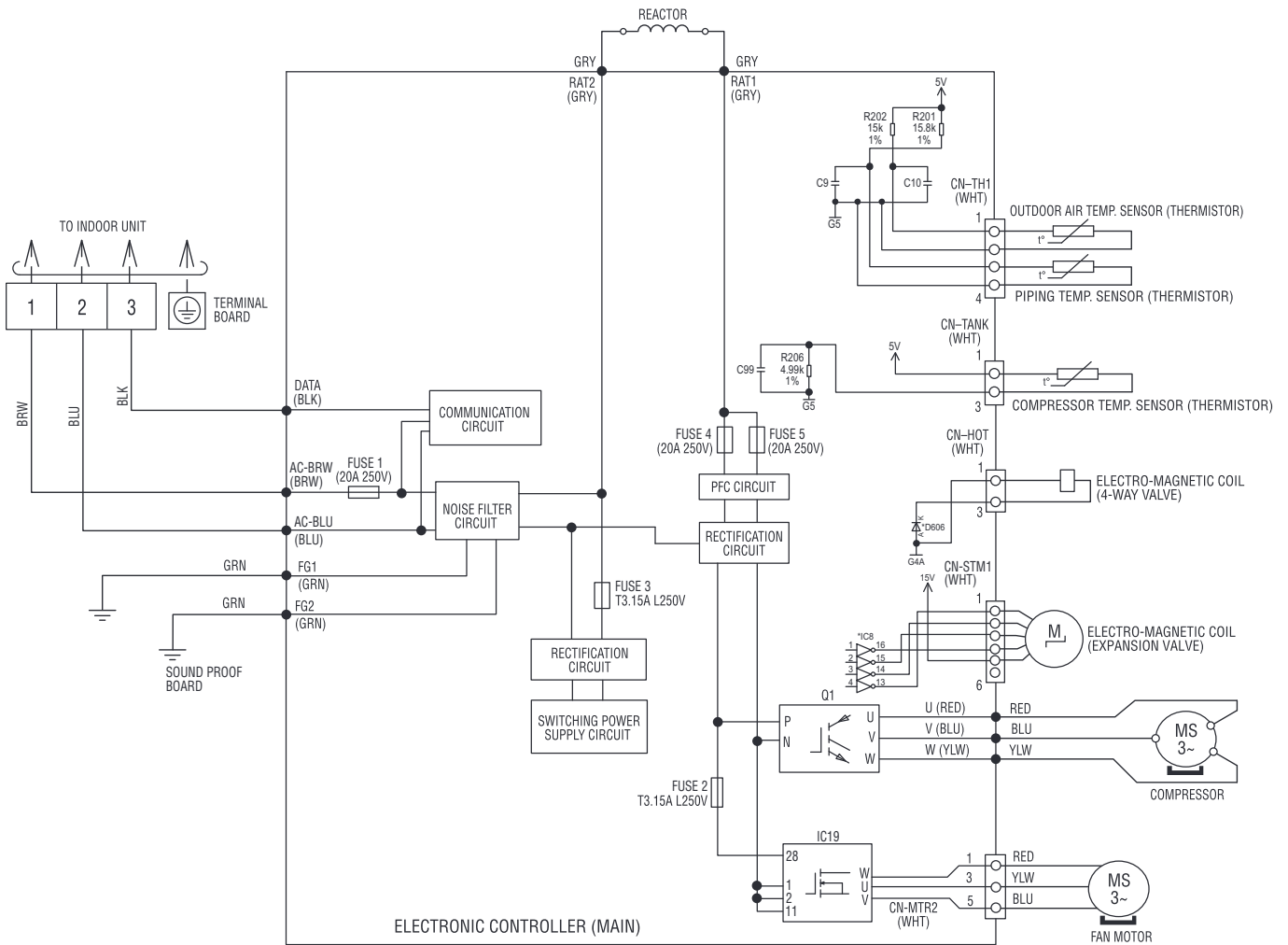

# 10.2.2 CU-Z50YKEA CU-Z71YKEA

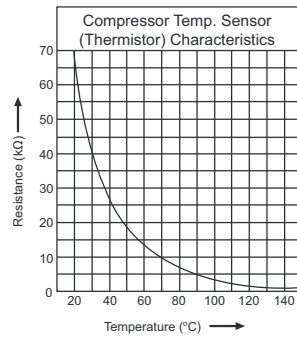
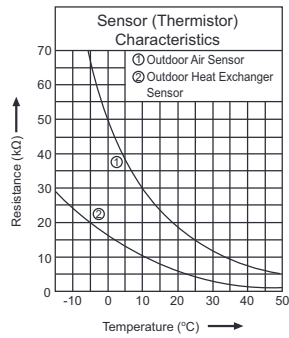
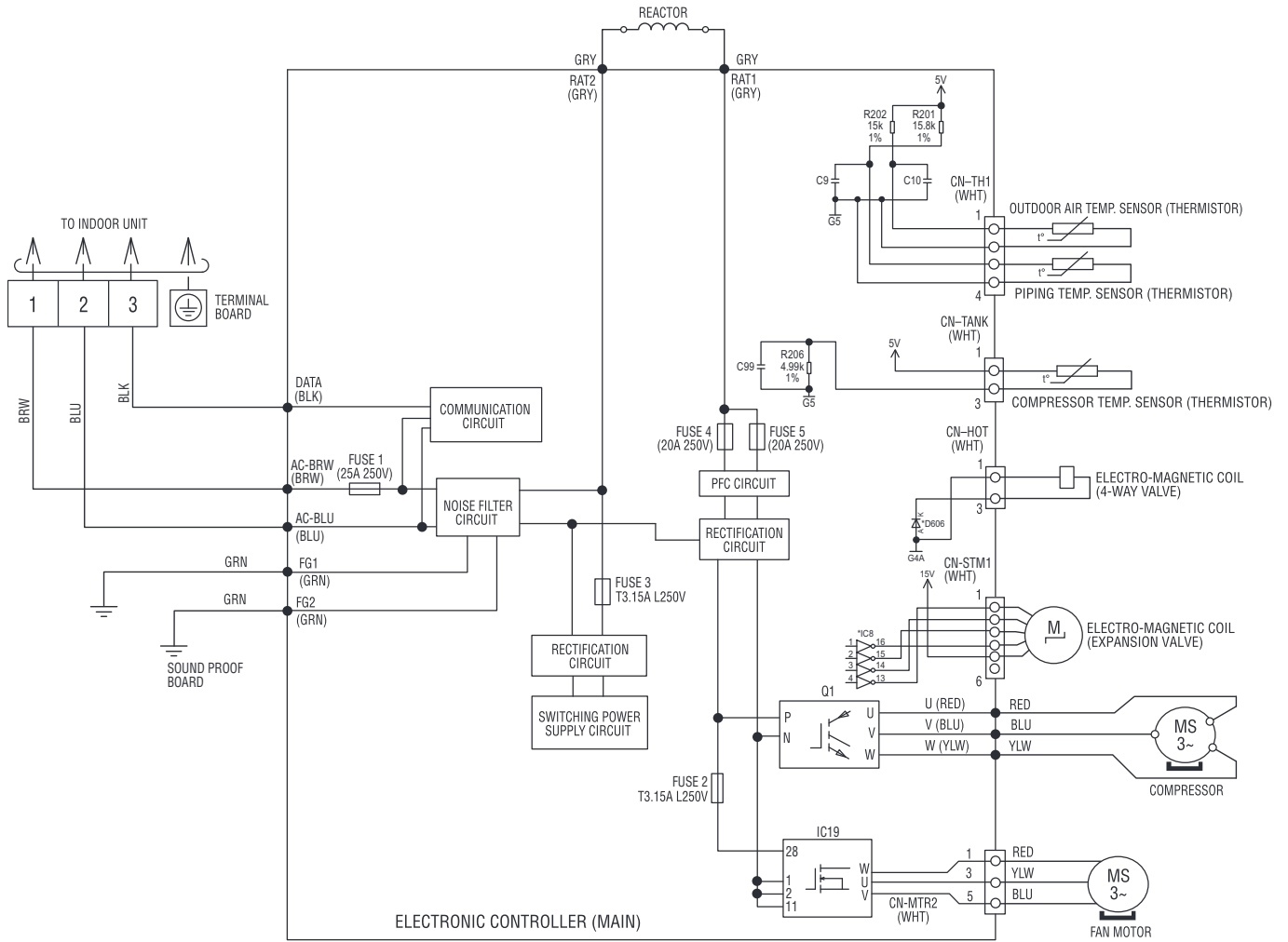

# 11. Printed Circuit Board

## 11.1 Indoor Unit

### 11.1.1 Main Printed Circuit Board

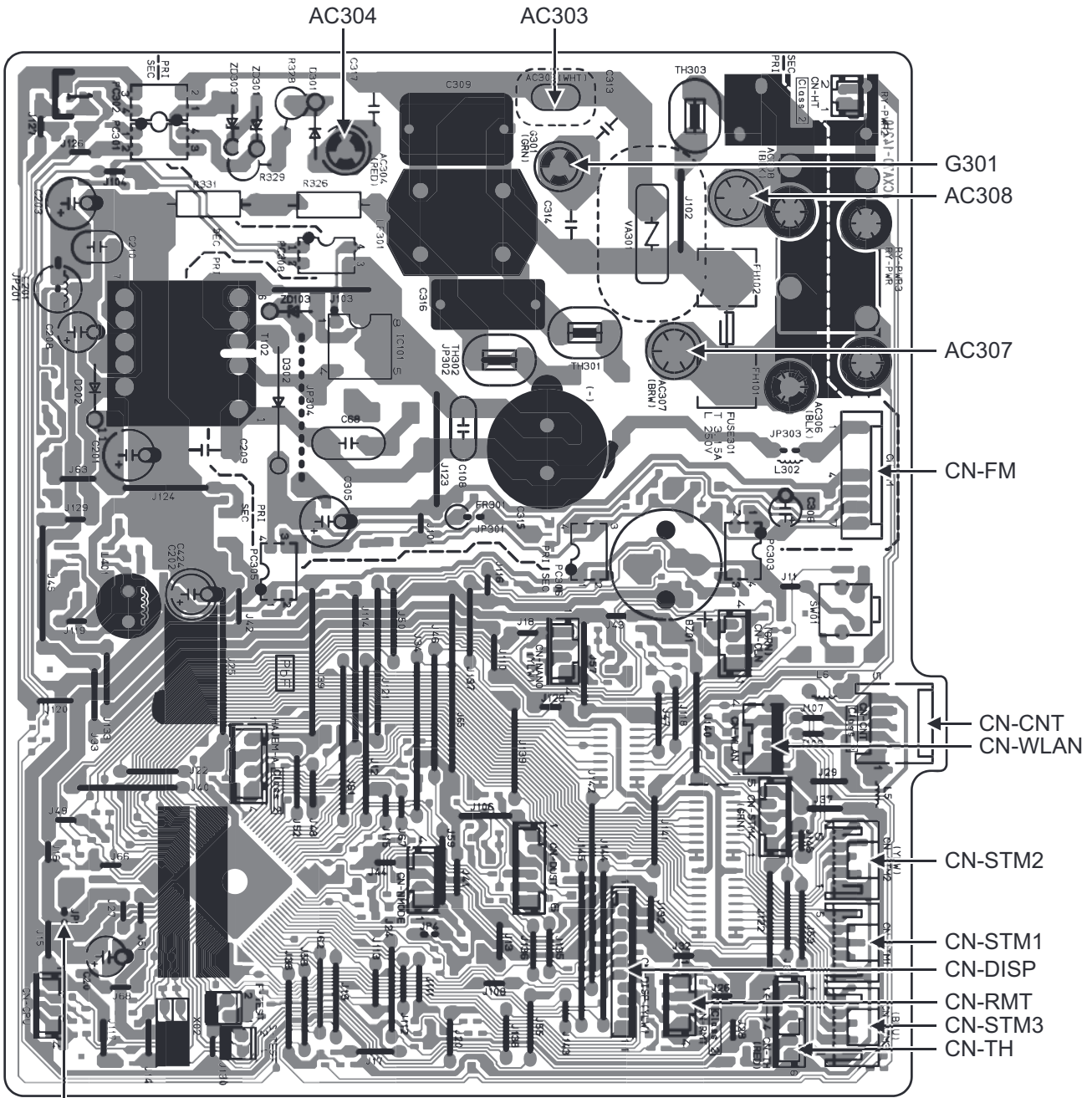

JP1 (Random Auto Restart enable/disable)

### 11.1.2 Indicator Printed Circuit Board

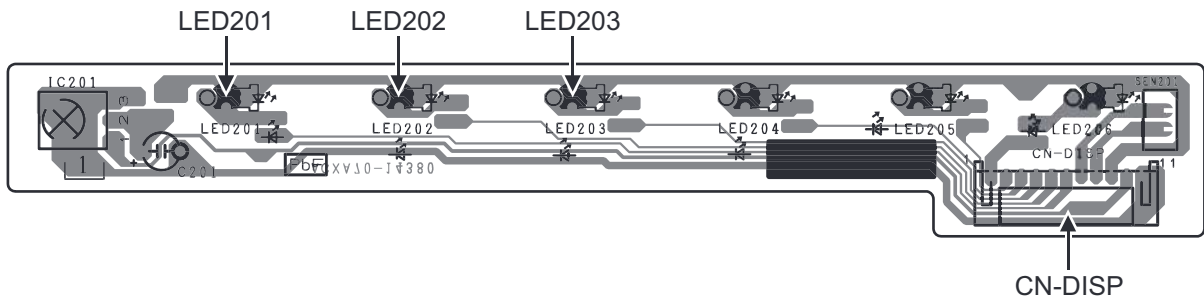

### 11.1.3 Wireless LAN Module Printed Circuit Board (Network Adapter)

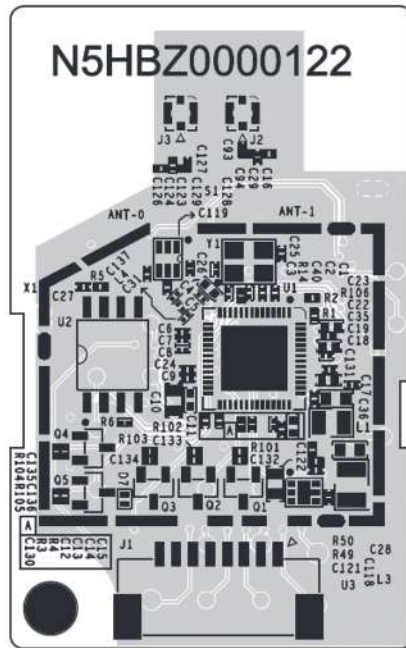

## 11.2 Outdoor Unit

### 11.2.1 Main Printed Circuit Board

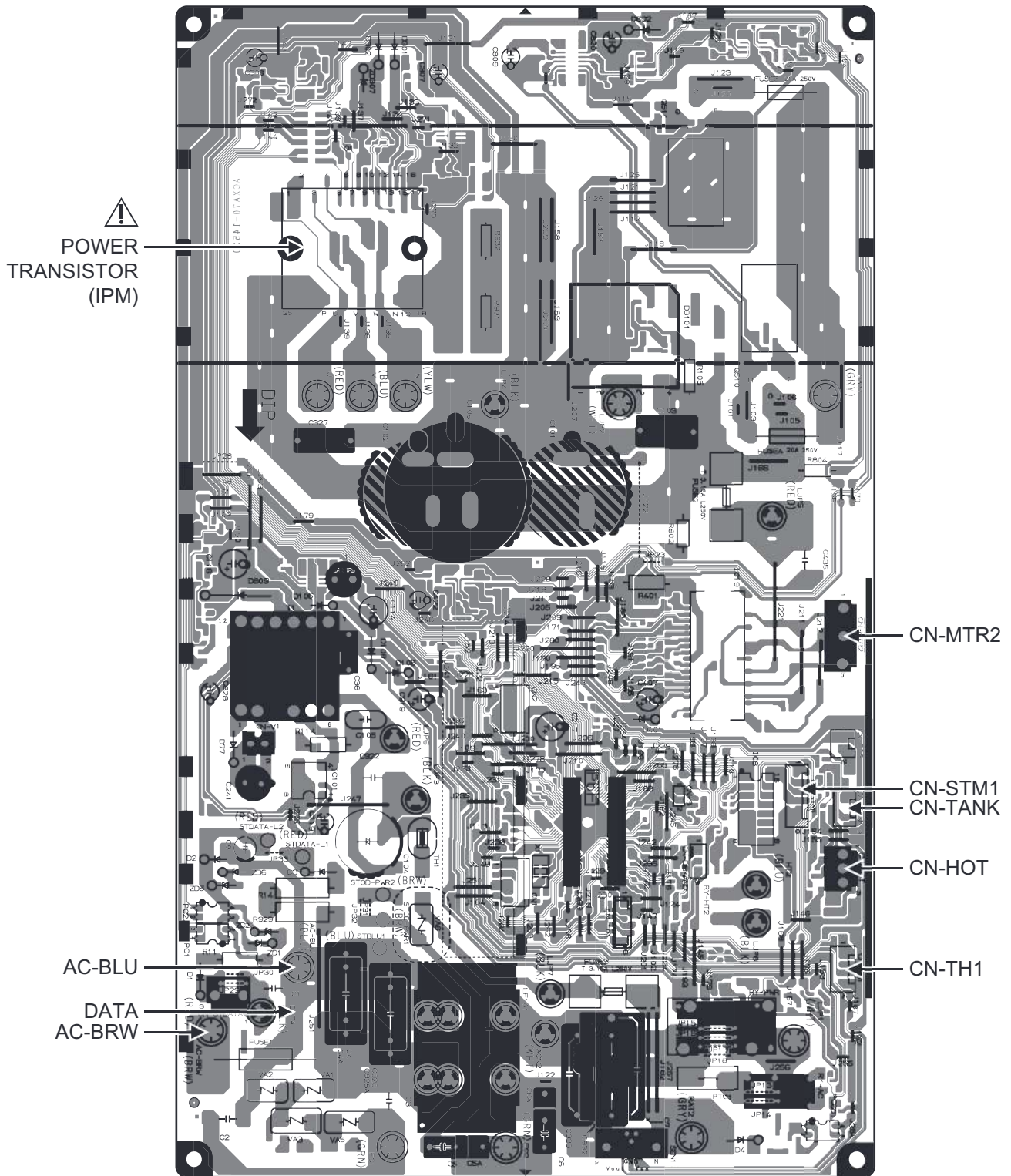

# 12. Installation Instruction

## 12.1 Select the Best Location

### 12.1.1 Indoor Unit

- Do not install the unit in excessive oil fume area such as kitchen, workshop and etc.
- There should not be any heat source or steam near the unit.
- There should not be any obstacles blocking the air circulation.
- A place where air circulation in the room is good.
- A place where drainage can be easily done.
- A place where noise prevention is taken into consideration.
- Do not install the unit near the door way.
- Ensure the spaces indicated by arrows from the wall, ceiling, fence or other obstacles.
- Indoor unit of this air conditioner shall be installed in a height of at least 1.8 m.

### 12.1.2 Outdoor Unit

- If an awning is built over the unit to prevent direct sunlight or rain, be careful that heat radiation from the condenser is not obstructed.
- There should not be any animal or plant which could be affected by hot air discharged.
- Keep the spaces indicated by arrows from wall, ceiling, fence or other obstacles.
- Do not place any obstacles which may cause a short circuit of the discharged air.
- If piping length is over the [piping length for additional gas], additional refrigerant should be added as shown in the table.

Table A

Model	Capacity W (HP)	Piping size		Std. Length (m)	Max. Elevation (m)	Min. Piping Length (m)	Max. Piping Length (m)	Additional Refrigerant (g/m)	Piping Length for add. gas (m)	Max. Refrigerant Charge (kg)	Indoor A <sub>min</sub> (m <sup>2</sup> )
		Gas	Liquid								
Z25***	1.0HP	9.52 mm (3/8")	6.35 mm (1/4")	5	15	3	20	10	7.5	1.02	Not applicable (*)
Z35***	1.5HP				15	3	20	10	7.5	1.02	Not applicable (*)
Z42***	1.75HP	12.7 mm (1/2")	15		3	20	10	7.5	1.10	Not applicable (*)	
Z50***	2.0HP		15		3	30	15	7.5	1.47	Not applicable (*)	
Z71***	2.5HP	15.88 mm (5/8")			20	3	30	25	10	1.85	4.46

(\*) Systems with total refrigerant charge,  $m_c$ , lower than 1.84kg are not subjected to any room area requirements.

Example: For Z25\*\*\*

If the unit is installed at 10 m distance, the quantity of additional refrigerant should be 25 g ....  $(10-7.5) \text{ m} \times 10 \text{ g/m} = 25 \text{ g}$ .

$$A_{\min} = (m_c / (2.5 \times (LFL)^{(5/4)} \times h_0))^2$$

\*\* not less than safety factor margin

- $A_{\min}$  = Required minimum room area, in m<sup>2</sup>
- $m_c$  = Refrigerant charge in appliance, in kg
- $LFL$  = Lower flammability limit (0.307 kg/m<sup>3</sup>)
- $h_0$  = Installation height of the appliance (1.8 m for wall mounted)
- $SF$  = Safety factor with a value of 0.75

\*\* The required minimum room area,  $A_{\min}$ , shall also be governed by the safety factor margin formula below :

$$A_{\min} = m_c / (SF \times LFL \times h_0)$$

The higher value shall be taken when determining the room area.

### 12.1.3 Indoor/Outdoor Unit Installation Diagram

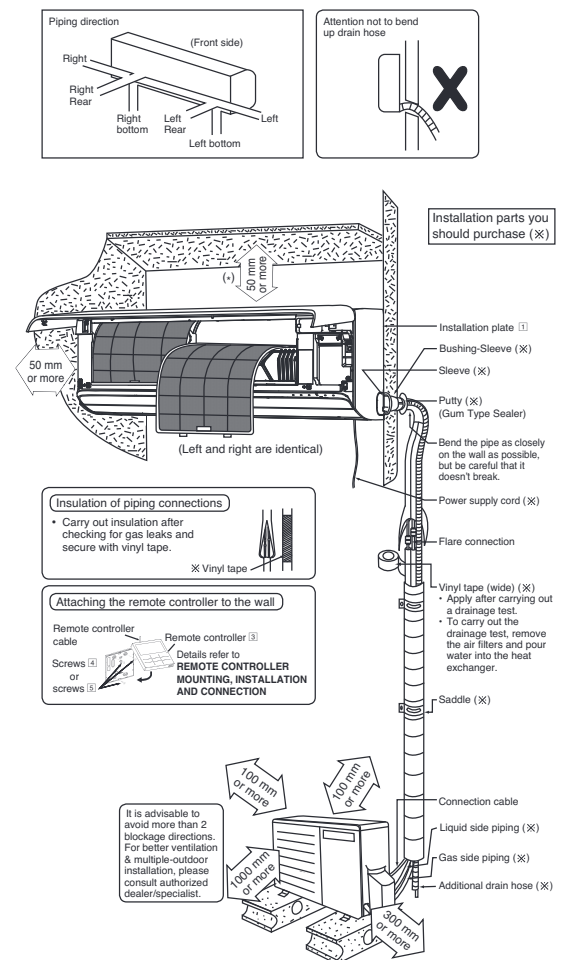

- This illustration is for explanation purposes only. The indoor unit will actually face a different way.

(\*) If holder at the rear of chassis (Refer column "12.2.3 Indoor Unit Installation") need to be used to prop up the unit, this distance shall be 65 mm or more.

## 12.2 Indoor Unit

### 12.2.1 How to Fix Installation Plate

The mounting wall shall be strong and solid enough to prevent it from vibration.

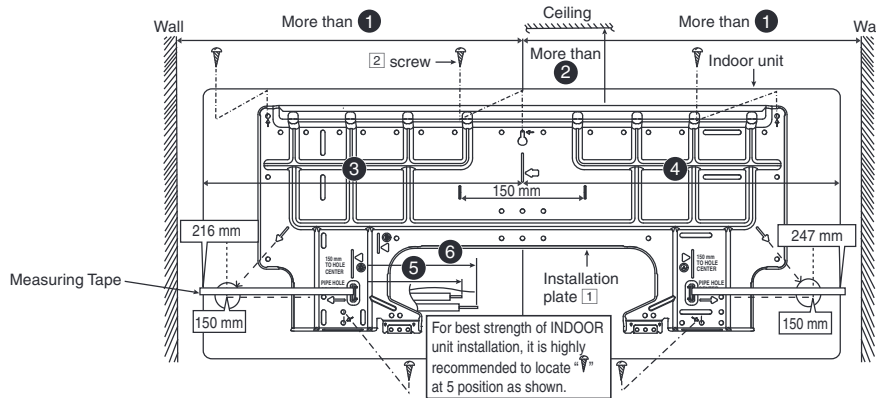

Model	Dimension					
	①	②	③	④	⑤	⑥
Z25***, Z35***, Z42***	500 mm	70 mm ( * )	420 mm	450 mm	113 mm	165 mm

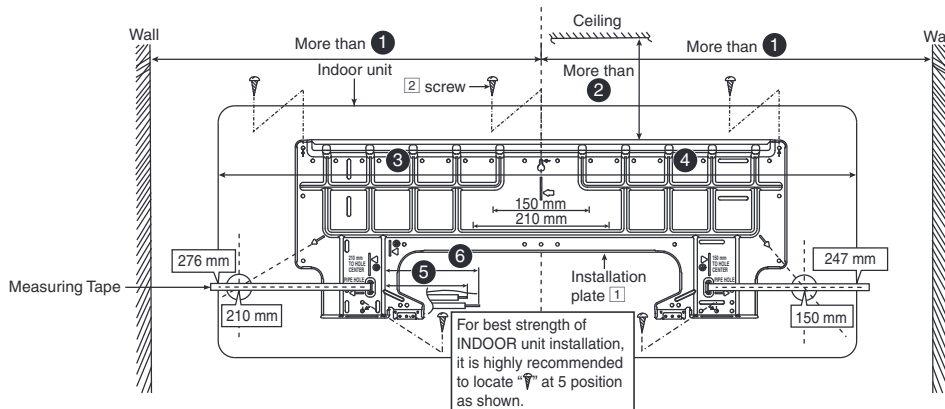

Model	Dimension					
	①	②	③	④	⑤	⑥
Z50***, Z71***	587 mm	70 mm ( * )	537 mm	503 mm	226 mm	278 mm

The center of installation plate should be at more than ① at right and left of the wall.

The distance from installation plate edge to ceiling should more than ②.

From installation plate center to unit's left side is ③.

From installation plate center to unit's right side is ④.

Ⓑ : For left side piping, piping connection for liquid should be about ⑤ from this line.

: For left side piping, piping connection for gas should be about ⑥ from this line.

Dimension ②
(*) :- If holder at the rear of chassis (Refer column "12.2.3 Indoor Unit Installation") need to be used to prop up the unit, this distance shall be 85 mm or more.

1 Mount the installation plate on the wall with 5 screws or more (at least 5 screws).

(If mounting the unit on the concrete wall, consider using anchor bolts.)

- Always mount the installation plate horizontally by aligning the marking-off line with the thread and using a level gauge.

2 Drill the piping plate hole with  $\varnothing 70$  mm hole-core drill.

- Line according to the left and right side of the installation plate.

The meeting point of the extended line is the center of the hole.

Another method is by putting measuring tape at position as shown in the diagram above.

The hole center is obtained by measuring the distance namely 150 mm for left and right hole respectively (Z25\*\*\*, Z35\*\*\*, Z42\*\*\*).

or 210 mm for left hole and 150 mm for right hole (Z50\*\*\*, Z71\*\*\*).

- Drill the piping hole at either the right or the left and the hole should be slightly slanting to the outdoor side.

### 12.2.2 To Drill a Hole in the Wall and Install a Sleeve of Piping

- 1 Insert the piping sleeve to the hole.
- 2 Fix the bushing to the sleeve.
- 3 Cut the sleeve until it extrudes about 15 mm from the wall.



#### CAUTION

- ❗ When the wall is hollow, please be sure to use the sleeve for tube assembly to prevent dangers caused by mice biting the connection cable.

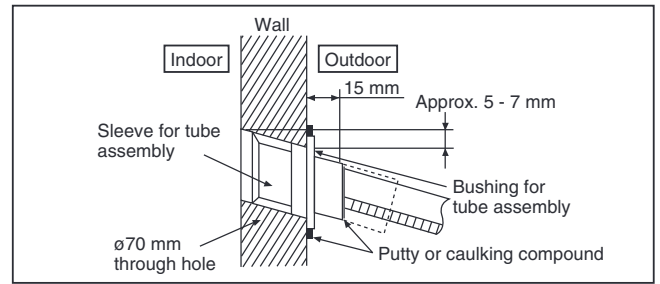

- 4 Finish by sealing the sleeve with putty or caulking compound at the final stage.

## 12.2.3 Indoor Unit Installation

### Pull out the Indoor piping

- Do not turn over the unit without shock absorber during pull out the piping. It may cause intake grille damage.
- Use shock absorber during pull out the piping to protect the intake grille from damage.

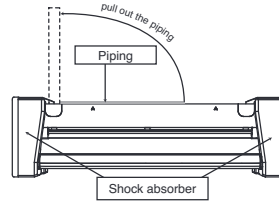
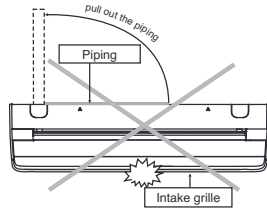

### 12.2.3.1 For the Right Rear Piping

**Step-1** Pull out the Indoor piping

**Step-2** Install the Indoor Unit

**Step-3** Secure the Indoor Unit

**Step-4** Insert the power supply cord and connection cable

- Insert the cables from bottom of the unit through the control board hole until terminal board area.

### 12.2.3.2 For the Right and Right Bottom Piping

**Step-1** Pull out the Indoor piping

**Step-2** Install the Indoor Unit

**Step-3** Insert the power supply cord and connection cable

- Insert the cables from bottom of the unit through the control board hole until terminal board area.

**Step-4** Secure the Indoor Unit

### 12.2.3.3 For the Embedded Piping

**Step-1** Change the drain hose position

**Step-2** Bend the embedded piping

- Use a spring bender or equivalent to bend the piping so that the piping is not crushed.

**Step-3** Pull the connection cable into Indoor Unit

- The power supply cord and indoor unit and outdoor unit connection cable can be connected without removing the front grille.

**Step-4** Cut and flare the embedded piping

- When determining the dimensions of the piping, slide the unit all the way to the left on the installation plate.
- Refer to the column "Cutting and flaring the piping".

**Step-5** Install the Indoor Unit

**Step-6** Connect the piping

- Please refer to "Connecting the piping" column in outdoor unit section. (Below steps are done after connecting the outdoor piping and gas-leakage confirmation.)

**Step-7** Insulate and finish the piping

- Please refer to "Insulation of piping connection" column as mentioned in indoor/outdoor unit installation.

**Step-8** Secure the Indoor Unit

- Fasten the chassis to the installation plate with screws (Self purchase, Screw size: M4, max. length 10 mm) to provide a neat appearance of indoor unit.

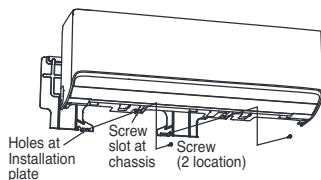

### Right Rear piping

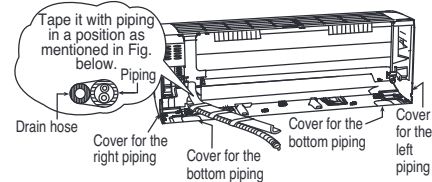

### How to keep the cover

In case of the cover is cut, keep the cover at the rear of chassis as shown in the illustration for future reinstallation. (Left, right and 2 bottom covers for piping.)

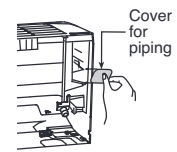

### Right and Right bottom piping

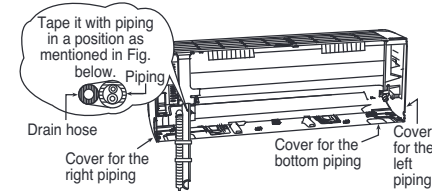

### Install the indoor unit

Hook the indoor unit onto the upper portion of installation plate. (Engage the indoor unit with the upper edge of the installation plate). Ensure the hooks are properly seated on the installation plate by moving it in left and right.

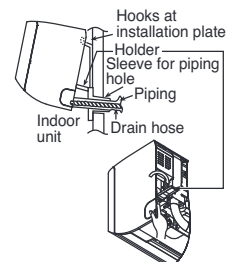

There is an option to use the holder at the rear of chassis to prop up the indoor unit as shown in the illustration for ease of installation. Push the holder back to original position before secure the indoor unit.

Alternatively, bottom plate of the indoor unit can be removed to enlarge the space for installation. Please refer column "How to take out front grille".

- Press the area of orange color to release holder.
- 1 holder (1.0 ~ 1.75HP) or 2 holder (2.0 ~ 2.5HP)

### Secure the Indoor Unit

Press the lower left and right side of the unit against the installation plate until hooks engages with their slot (sound click).

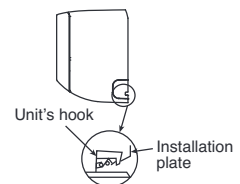

### Insert the connection cable

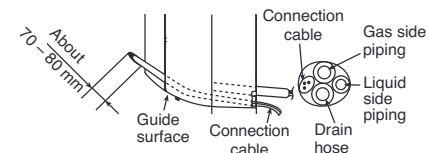

To take out the unit, push the  $\nabla$  marking at the bottom unit, and pull it slightly towards you to disengage the hooks from the unit.

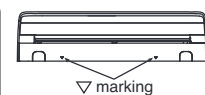

(This can be used for left rear piping also.)

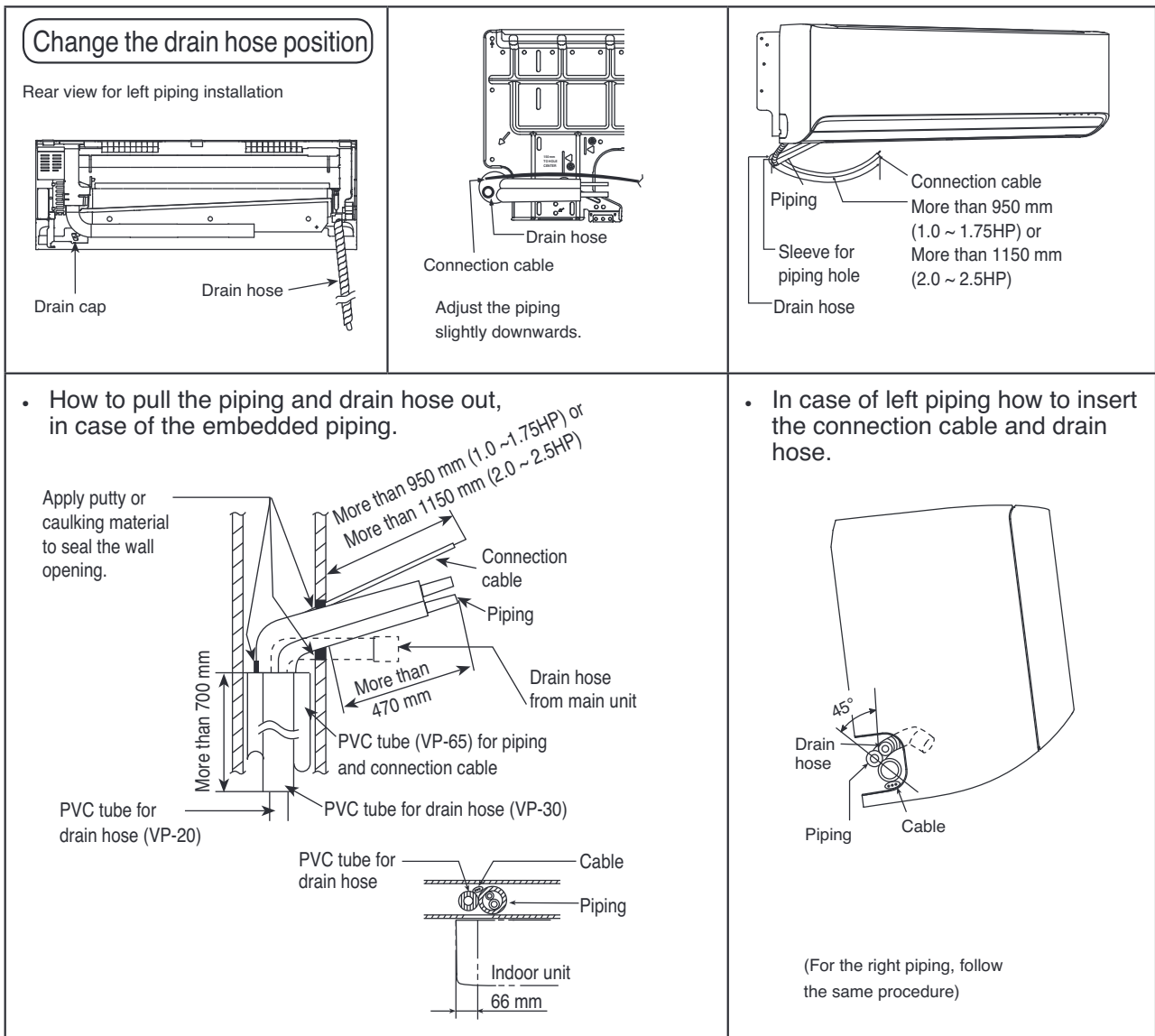

### 12.2.4 Connect the Cable to the Indoor Unit

The power supply cord, indoor and outdoor unit connection cable can be connected without removing the front grille.

- 1 Install the indoor unit on the installing holder that mounted on the wall.
- 2 Open the front panel and grille door by loosening the screw.
- 3 Cable connection to the power supply through Isolating Devices (Disconnecting means).
  - Connect the approved polychloroprene sheathed power supply cord  $3 \times 1.5 \text{ mm}^2$  (1.0 ~ 1.75HP) or  $3 \times 2.5 \text{ mm}^2$  (2.0 ~ 2.5HP), type designation 60245 IEC 57 or heavier cord to the terminal board, and connect the other end of the cable to Isolating Devices (Disconnecting means).
  - Do not use joint power supply cord. Replace the wire if the existing wire (from concealed wiring, or otherwise) is too short.
  - In unavoidable case, joining of power supply cord between isolating devices and terminal board of air conditioner shall be done socket and plug rated 15/16 A (1.0 ~ 1.75HP) or 16 A (2.0HP) or 20 A (2.5HP). Wiring work to both socket and plug must follow to national wiring standard.
- 4 Bind all the **power supply cord** lead wire with tape and route the power supply cord via the left side escapement.
- 5 **Connection cable** between indoor unit and outdoor unit shall be approved polychloroprene sheathed  $4 \times 1.5 \text{ mm}^2$  (1.0 ~ 1.75HP) or  $4 \times 2.5 \text{ mm}^2$  (2.0 ~ 2.5HP) flexible cord, type designation 60245 IEC 57 or heavier cord.
- 6 Bind all the indoor and outdoor **Connection cable** with tape and route the connection cable via the right side escapement.
- 7 Remove the tapes and connect the power supply cord and connection cable between indoor unit and outdoor unit according to the diagram below.

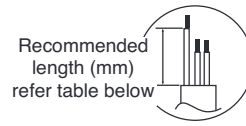
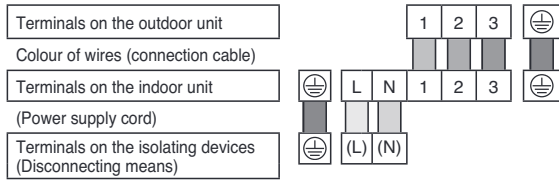
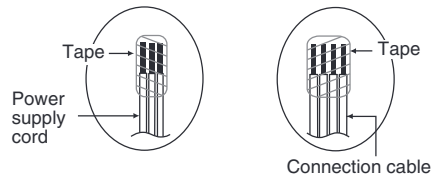

**WARNING**  
This equipment must be properly earthed.

Recommended length (mm)	a	b	c	d	e	f	g
	30	30	60	45	40	35	55

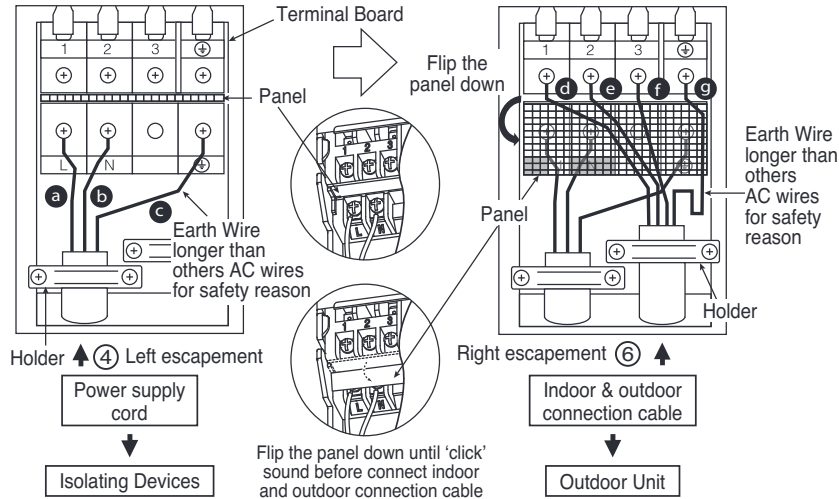

- 8 Secure firmly the power supply cord and connecting cable onto the control board with the holder. Do not overtighten holder screw, as this may damage the holder.
- 9 Close grille door by tighten with screw and close the front panel.

**Note:**

- Isolating Devices (Disconnecting means) should have minimum 3.0 mm contact gap.
- Ensure the colour of wires of outdoor unit and the terminal Nos. are the same to the indoor's respectively.
- Earth wire shall be Yellow/Green (Y/G) in colour and longer than other AC wires as shown in the figure for the electrical safety in case of the slipping out of the cord from the anchorage.

### 12.2.4.1 Wire Stripping Connecting and Requirement

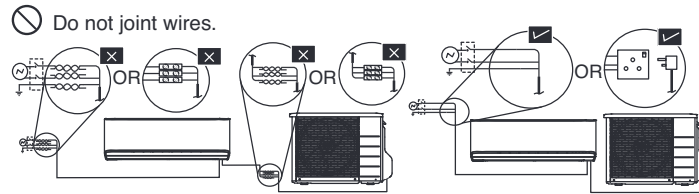
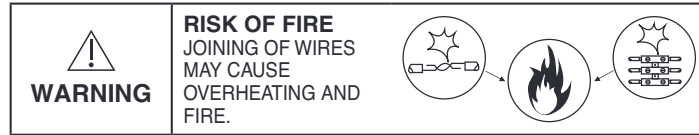
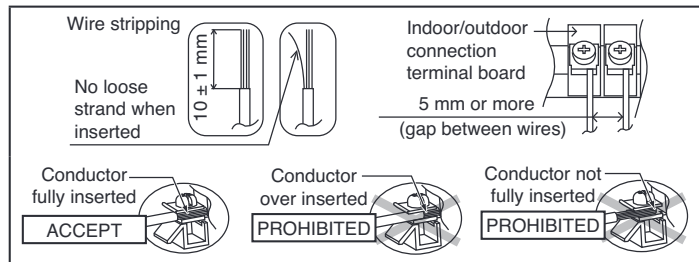

- ! Use complete wire without joining.
- ! Use approved socket and plug with earth pin.
- ! Wire connection in this area must follow to national wiring rules.

## 12.3 Outdoor Unit

### 12.3.1 Install the Outdoor Unit

- After selecting the best location, start installation to Indoor/Outdoor Unit Installation Diagram.
  - Fix the unit on concrete or rigid frame firmly and horizontally by bolt nut ( $\varnothing 10$  mm).  
Make sure unit install in balance level to ensure that water flow out from unit drainage hole.
  - When installing at roof, please consider strong wind and earthquake.  
Please fasten the installation stand firmly with bolt, screws or nails.

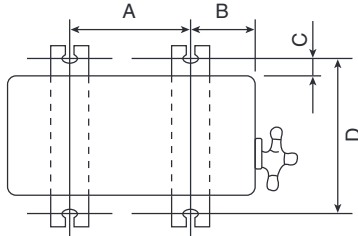

Model	A	B	C	D
Z25***, Z35***, Z42***	570 mm	105 mm	18.5 mm	320 mm
Z50***, Z71***	613 mm	131 mm	24 mm	360.5 mm

### 12.3.2 Connect the Piping

#### 12.3.2.1 Connecting the Piping to Indoor

For connection joint of all model

Please make flare after inserting flare nut (locate at joint portion of tube assembly) onto the copper pipe.  
(In case of using long piping)

Connect the piping

- Align the center of piping and sufficiently tighten the flare nut with fingers.
- Further tighten the flare nut with torque wrench in specified torque as stated in the table.

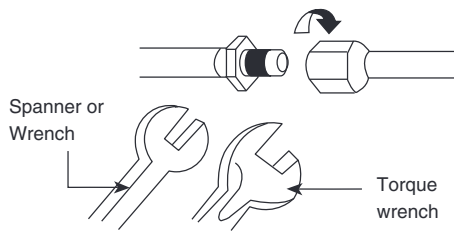

#### Additional Precautions For R32 Models when connecting by flaring at indoor side

⚠ Ensure to do the re-flaring of pipes before connecting to units to avoid leaking.

Seal sufficiently the flare nut (both gas and liquid sides) with neutral cure (Alkoxy type) & ammonia-free silicone sealant and insulation material to avoid the gas leak caused by freezing.

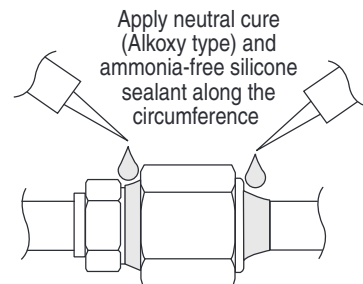

Neutral cure (Alkoxy type) & ammonia-free silicone sealant is only to be applied after pressure testing and cleaning up by following instructions of sealant, only to the outside of the connection. The aim is to prevent moisture from entering the connection joint and possible occurrence of freezing. Curing sealant will take some time. Make sure sealant will not peel off when wrapping the insulation.

#### 12.3.2.2 Connecting the Piping to Outdoor

Decide piping length and then cut by using pipe cutter. Remove burrs from cut edge.

Make flare after inserting the flare nut (locate at valve) onto the copper pipe. Align center of piping to valve and then tighten with torque wrench to the specified torque as stated in the table.

⚠ Do not overtighten, overtightening may cause gas leakage.

Piping size	Torque
6.35 mm (1/4")	[18 N•m (1.8 kgf•m)]
9.52 mm (3/8")	[42 N•m (4.3 kgf•m)]
12.7 mm (1/2")	[55 N•m (5.6 kgf•m)]
15.88 mm (5/8")	[65 N•m (6.6 kgf•m)]
19.05 mm (3/4")	[100 N•m (10.2 kgf•m)]

### 12.3.3 Air Tightness Test on the Refrigerating System

 Do not purge the air with refrigerants but use a vacuum pump to vacuum the installation.

 There is no extra refrigerant in the outdoor unit for air purging.

- Before system is charged with refrigerant and before the refrigerating system is put into operation, below site test procedure and acceptance criteria shall be verified by the certified technicians, and/or the installer.
- Be sure to check whole system for gas leakage.

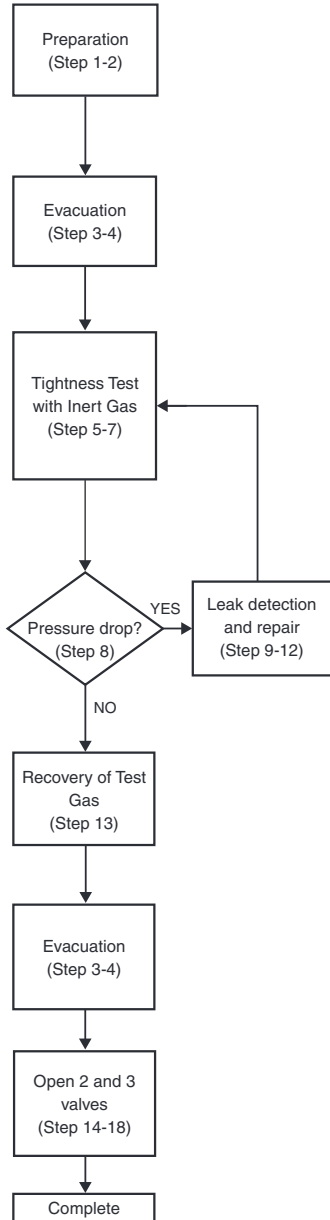

- 1 Connect a charging hose with a push pin to the Low side of a charging set and the service port of the 3-way valve.
- 2 Attach the gauge manifold set correctly and tightly. Make sure that both valves of the manifold gauge (low pressure and high pressure) is in close position.
- 3 Connect the center hose of the manifold gauge to a vacuum pump.
- 4 Turn on the power switch of the vacuum pump, then turn open the low side manifold gauge valve and make sure that the needle in the gauge moves from 0cmHg (0 MPa) to -76 cmHg (-0.1 MPa) or vacuum until 500 microns is achieved. This process continues for approximately ten minutes. Then close the low side manifold gauge valve.
- 5 Remove the vacuum pump from the centre hose and connect the center hose to cylinder of any applicable inert gas as test gas.
- 6 Charge test gas into the system and wait until the pressure within the system to reach min. 1.04MPa (10.4barg).
- 7 Wait and monitor the pressure reading on the gauges. Check if there is any pressure drop.  
Waiting time depends on the size of the system.
- 8 If there is any pressure drop, perform step 9-12. If there is no pressure drop, perform step 13.
- 9 Use Gas Leak Detector to check for leaks. Must use the detection equipment with a sensitivity of 5 grams per year of test gas or better.
- 10 Move the probe along the air conditioning system to check for leaks, and mark for repair.
- 11 Any leak detected and marked shall be repaired.
- 12 After repair, repeat evacuation steps 3-4 and tightness test steps 5-7. Check the pressure drop as in step 8.
- 13 If no leak, Recover the test gas. Perform evacuation of steps 3-4. Then proceed to step 14.
- 14 Disconnect the charging hose from the service port of the 3-way valve.

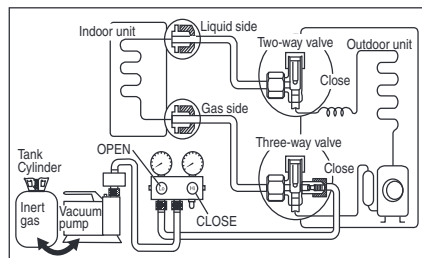

- 15 Tighten the service port caps of the 3-way valve at a torque of 18 N•m with a torque wrench.
- 16 Remove the valve caps of both of the 2-way valve and 3-way valve.
- 17 Open both of the valves, using a hexagonal wrench (4 mm).  
It is recommended to allow refrigerant slowly flow into the refrigerant system to prevent refrigerant freezing. Slightly open 2-way valve for 5 seconds then close the valve. Repeat this action for 3 cycles then fully open the valve.
- 18 Mount back the valve caps onto the 2-way valve and the 3-way valve to complete this process.







**Notes:**

Recommended use of any of the following leak detector,

- I) Universal Sniffer leak detector
- II) Electronic halogen leak detector
- III) Ultrasonic Leak Detector



### 12.3.4 Connect the Cable to the Outdoor Unit

- 1 Remove the control board cover from the unit by loosening the screw.
- 2 **Connection cable** between indoor unit and outdoor unit shall be approved polychloroprene sheathed 4 x 1.5 mm<sup>2</sup> (1.0 ~ 1.75HP) or 4 x 2.5 mm<sup>2</sup> (2.0 ~ 2.5HP) flexible cord, type designation 60245 IEC 57 or heavier cord. Do not use joint connection cable. Replace the wire if the existing wire (from concealed wiring, or otherwise) is too short.

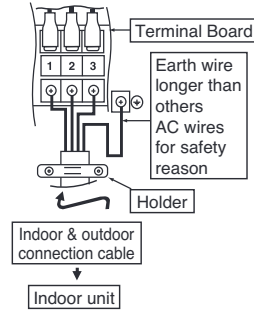
Terminals on the outdoor unit	1	2	3	
Colour of wires				
Terminals on the indoor unit	1	2	3	



- 3 Secure the cable onto the control board with the holder (clammer).
- 4 Attach the control board cover back to the original position with screw.
- 5 For wire stripping and connection requirement, refer to instruction 12.2.4 of indoor unit.

 <b>WARNING</b>
 This equipment must be properly earthed.

- Earth wire shall be Yellow/Green (Y/G) in colour and longer than other AC wires for safety reason.

### 12.3.5 Piping Insulation

- 1 Please carry out insulation at pipe connection portion as mentioned in Indoor/Outdoor Unit Installation Diagram. Please wrap the insulated piping end to prevent water from going inside the piping.
- 2 If drain hose or connecting piping is in the room (where dew may form), please increase the insulation by using POLY-E FOAM with thickness 6 mm or above.

#### 12.3.5.1 Cutting and Flaring the Piping

- 1 Please cut using pipe cutter and then remove the burrs.
- 2 Remove the burrs by using reamer. If burrs is not removed, gas leakage may be caused. Turn the piping end down to avoid the metal powder entering the pipe.
- 3 Please make flare after inserting the flare nut onto the copper pipes.

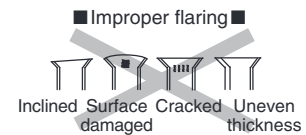
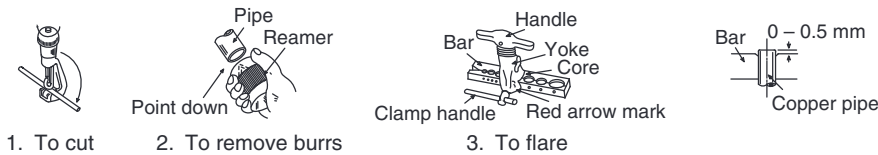

When properly flared, the internal surface of the flare will evenly shine and be of even thickness. Since the flare part comes into contact with the connections, carefully check the flare finish.

## 12.3.6 Remote Controller Mounting, Installation and Connection

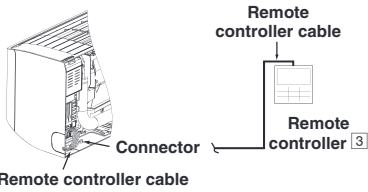

**CAUTION**

Install the remote controller cable at least 5 cm away from electric wires of other appliances to avoid miss-operation (electromagnetic noise).

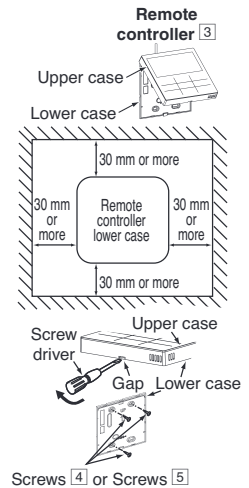

### Remote Controller Mounting Location

- Allow sufficient space around the remote controller ③ as shown in the illustration at right.
- Install in a place which is away from direct sunlight and high humidity.
- Install in a flat surface to avoid warping of the remote controller. If installed to a wall with an uneven surface, damage to the LCD case or operation problems may result.
- Install in a place where the LCD can be easily seen for operation. (Standard height from the floor is 1.2 to 1.5 meters.)
- Avoid installing the remote controller cable near refrigerant pipes or drain pipes, else it will cause electrical shock or fire.

### Remote Controller Installation

- Remove the remote controller ③ lower case. (Insert a flat-tipped screw driver or similar tool 2 to 3 mm into the gap at the bottom of the case, and twist to open. Refer to the illustration at right.) Be careful not to damage the lower case.
- Do not remove the protective film which is affixed to the upper case circuit board when remove the remote controller lower case.
- Secure the lower case to an outlet box or wall. Refer to (A) or (B) instructions below depending on your choice of cable installation.
- Be sure to use only the screws provided.
- Do not over tighten the screws, as it may result in damage to the lower case.

### A. IF REMOTE CONTROLLER CABLE IS EMBEDDED

- Embed an outlet box (JIS C 8336) into the wall. Outlet box maybe purchased separately. Medium size square outlet box (obtain locally) Part No. DS3744 (Panasonic Co., Ltd.) or equivalent.
- Secure the remote controller lower case to the outlet box with the three accessory screws ④. Make sure that the lower case is flat against the wall at this time, with no bending.
- Pass the remote controller cable into the box.
- Route the remote controller cable inside the lower case through rear feeding-out direction.
- Insert firmly the connector of remote controller cable to connector (CN-RMT) in the upper case circuit board. (Refer to the illustration at below.)
- Secure the remote controller upper case to the lower case with the tabs provided.

### CAUTION

When the wall is hollow, please be sure to use the sleeve for remote controller cable to prevent dangers caused by mice biting the cable.

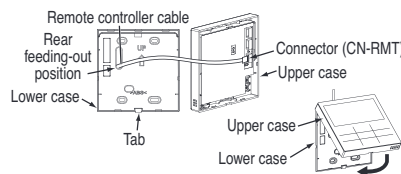
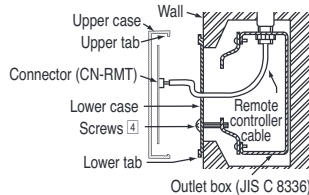

### B. IF REMOTE CONTROLLER CABLE IS EXPOSED

- Install the remote controller lower case to the wall with the three accessory screws ⑤.
- Fasten the screws properly until screw head is lower than the rib and reach the base of remote controller lower case to ensure they do not damage the PCB inside the remote controller ③.
- The feeding-out direction for the remote controller cable shall be via the top side.
- Use nipper to cut a notch at the upper case.
- Route the remote controller cable inside the upper case. (Refer to the illustration at right).
- Insert firmly the connector of remote controller cable to connector (CN-RMT) in the upper case circuit board. (Refer to the illustration at right)
- Secure the remote controller upper case to the lower case with the tabs provided.

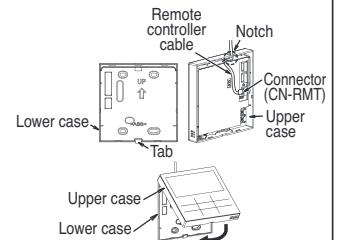
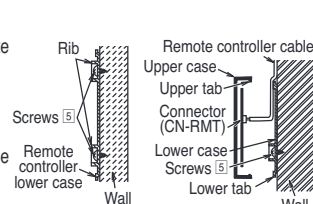

## 12.3.7 How to Take Out Front Grille

Please follow the steps below to take out front grille if necessary such as when installing or servicing.

Model	Z25***, Z35***, Z42***
-------	------------------------

- Pull down 3 caps at the bottom, then remove 3 mounting screws.
- Cling finger around screw area slot, pull the bottom plate downward until a click sound indicates hook is unleashed. Move the bottom plate forward carefully.
- Open front panel.
- Remove 3 mounting screws on the front grille.
- Slide the 3 lock knobs on the upside of front grille to unlock position.
- Set the upper vane to horizontal position. Set the lower vane to slightly below horizontal position.
- Pull the front grille towards you to remove the front grille.

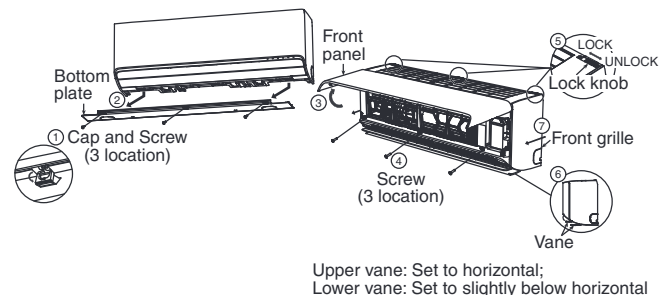

Model	Z50***, Z71***
-------	----------------

- 1 Pull down 3 caps at the bottom, then remove 3 mounting screws.
- 2 Open front panel.
- 3 Remove 3 mounting screws on the front grille.
- 4 Slide the 4 lock knobs on the upside of front grille to unlock position
- 5 Pull the front grille towards you to remove the front grille.

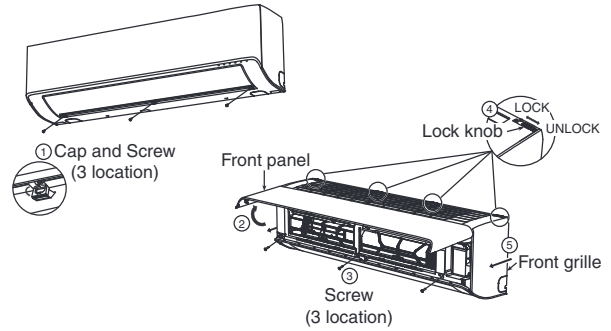

### 12.3.8 Disposal of Outdoor Unit Drain Water

- If a drain elbow is used, the unit should be placed on a stand which is taller than 3 cm.
- If the unit is used in an area where temperature falls below 0°C for 2 or 3 days in succession, it is recommended not to use a drain elbow, for the drain water freezes and the fan will not rotate.

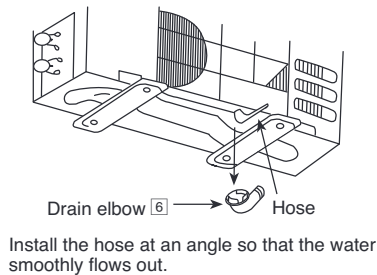

### 12.3.9 How to Replace Network Adapter

- Remove the front grille (refer how to take out front grille) from the unit.
- Remove the indicator piece by releasing the hook.
- Remove 1 mounting screw, then remove the network adaptor holder.
- After that, network adaptor can be easily replaced.

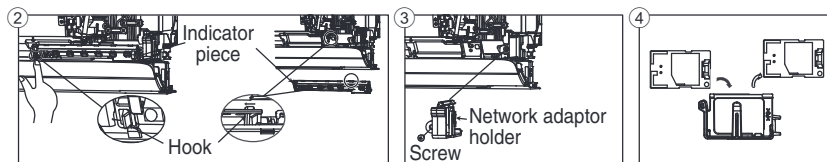

### 12.3.10 Check the Drainage

- Open front panel and remove air filters. (Drainage checking can be carried out without removing the front grille.)
- Pour a glass of water into the drain tray-styrofoam.
- Ensure that water flows out from drain hose of the indoor unit.

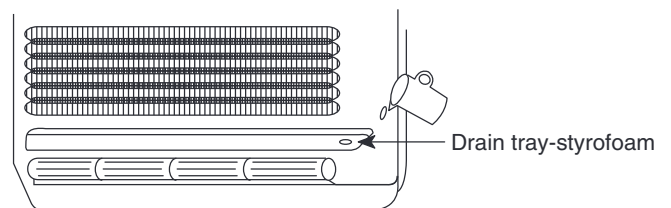

### 12.3.11 Evaluation of the Performance

- Operate the unit at cooling/heating operation mode for fifteen minutes or more.
- Measure the temperature of the intake and discharge air.
- Ensure the difference between the intake temperature and the discharge is more than 8°C during Cooling operation or more than 14°C during Heating operation.

Note:

- During extremely cold winter, turn on the power supply and standby the unit for at least 15 minutes before test run. Allow sufficient time to warm up refrigerant and prevent wrong error code judgement.

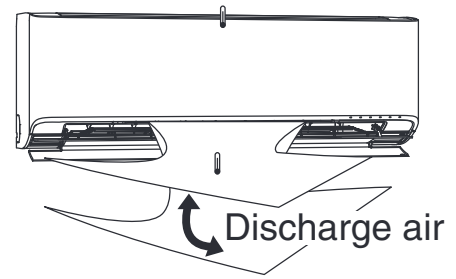

## 13. Installation and Servicing Air Conditioner using R32

### 13.1 About R32 Refrigerant

For air conditioning refrigerants such as R410A, the refrigerants were collected back in order to prevent their air dissipation, to curbe the global warming impact, in case they were released into the atmosphere. In the “4th Environmental Basic Plan”, 80% reduction of greenhouse gas emissions by 2050 is required, and due to this requirement, further reduction in the emission of high greenhouse effect gas, such as CFCs, is required. Therefore, the conversion of air conditioning refrigerant into the ones who has smaller greenhouse effect, even if it is dissipated into the atmosphere, became our responsibility.

Nevertheless, in case of air conditioning refrigerant, it would be the best if there is a refrigerant which has smaller impact on global warming, but ensures good energy efficiency and performance, and is safe; however, there is no such refrigerant which satisfies all these conditions. As a result, we have been considering the practical usage, within the safety frame-work, of R32 refrigerant which has short lifetime in the atmosphere, and has smaller effect of global warming, but is slightly flammable.

In 2004, due to the revision of air conditioner safety standards by the International Electro-safety Commission (IEC), the safety standards of air conditioners using slightly flammable refrigerant was issued. In 2010, the regulations of American Society of Heating, Refrigerating and Air-Conditioning Engineers in the United States (ANSI/ASHRAE34) was issued adopting the grades for refrigerants which are difficult to inflame due to their slow burning rates, and as a result have smaller damages in cases of fire. The burning rate of R32 is lower by 10cm / per second, and safety standardization for various usage is now being processed.

### 13.2 Characteristics of R32 Refrigerant

#### 1. Chemical Characteristics

R32 is one of the refrigerants used in R410A, has almost no toxicity, and chemically stable compound formed by hydrogen, carbon and fluorine.

R32 has short lifetime of 4 to 9 years in case of being released into the atmosphere; therefore, it has smaller greenhouse gas effect but has slight inflammability because of the large proportion of hydrogen.

Chemical Characteristic Table of R32, R410A and R22.

	R32	R410A	R22
Chemical Formula	CH <sub>2</sub> F <sub>2</sub>	CH <sub>2</sub> F <sub>2</sub> / CHF <sub>2</sub> CF <sub>3</sub>	CH <sub>2</sub> ClF
Composition (mixture ratio wt.%)	Single Composition	R32 / R125A (50 / 50 wt.%)	Single Composition
Boiling Point (°C)	-51.7	-51.5	-40.8
Pressure (physical) *1	3.14	3.07	1.94
Capacity (physical) *2	160	141	100
COP (physical) *3	95	91	100
Ozone Depletion Potential (ODP)	0	0	0.055
Global Warming Potential (GWP) *4	675	2090	1810
Inflammability *5	Slightly Inflammable (A2L)	Non-inflammable (A1)	Non-inflammable (A1)
Toxicity	None	None	None

\*1 : Physical property of temperature condition 50°C

\*2 : Relative value of temperature condition 0/50°C, providing R22=100

\*3 : Te/Tc/SC/SH=5/50/3/0°C

\*4 : GWP=Global Warming Potential, each figure is based on “4<sup>th</sup> IPCC4 Report”

\*5 : Based on ANSI / ASHRAE std. 34-2010

## 2. Characteristic of Pressure

As shown in Table 2, R32 does not have much difference in vapor pressure at the same refrigerant temperature comparing to R410A, but comparing to R22, it is higher at 1.6 times more. Thus, the same as in case of R410A, it is necessary to do installation and service using high-pressure tools and components.

Table 2. Saturated vapor pressure comparison table

(Unit: MPa)

Temperature	Refrigerant		
	R32	R410A	R22
-20	0.30	0.30	0.14
0	0.71	0.70	0.40
20	1.37	1.35	0.81
40	2.38	2.32	1.43
60	3.84	3.73	2.33
65	4.29	4.17	2.60

Reference : Thermal properties table of Japan Society of Refrigerating and Air Conditioning Engineers (60, 65°C)  
NIST REFPROP V8.0 (-20 ~ 40°C)

## 13.3 Refrigerant piping installation • Tools used in services

### 13.3.1 Required Tools

R32 refrigerant air conditioners use the common parts as R410A air conditioners for two-way valves and three-way valves (diameters of service ports); thus, they maintain commonality in the maintenance of the compressive strength, the size of pipe flaring, and the size of flare nuts as R410A. Therefore, for refrigerant pipe installation and services, you can use tools for R410A.

However, mixing of refrigerants is not allowed, so that you have to separate the cylinders for the recovery of refrigerants.

Tools used for installation • relocation • replacement of air conditioning units

Works	R32	R410A	R22
Flaring	Flare tools for R410A (clutch type)		Flare tools for R22 (clutch type)
Connection of pipes	Torque wrench (diameter 1/4 3/8)		
	Torque wrench (diameter 1/2 5/8) *1		Toque wrench (diameter 1/2 5/8)
Manifold gauge charging hose	R32 & R410A Common (As at November 2013)		R22 Only
Air purging	Vacuum pump + Reducer / expander		Vacuum pump
Gas leakage test	Detection liquid or soup water, HFC detector		

\*1. Nut diameters of 1/2 5/8, the size of torque wrench common with R410A

For other installation, you can use general tools such as screw drivers (+, -), metal saws, electric drills, long-nose pliers, hole core drills ( $\phi 70$  or  $\phi 65$ ), linen tape, levels, temperature gauges, clamp meters, electric knives, nippers, pipe cutters, reamers or scrapers, spring benders, (diameters 1/4 3/8 1/2 5/8), monkey wrenches, fixing wrenches (17 or 12 mm), feeler gauges, hexagon wrenches (4 mm), testers, megohm testers, etc.

Tools used for services

Works	R32	R410A	R22
Insertion of refrigerant	Digital scale for refrigerant charging, refrigerant cylinders, cylinder adopters and packing *a		
Recovery of refrigerant	Refrigerant recovery devices, refrigerant cylinders, manifold gauges, charging hoses *b		

\*a. Use cylinder for each refrigerant, cylinder adopter and packing.

\*b. Use refrigerant recovery cylinder separately for each refrigerant (**no mixture of refrigerant allowed**). Please be aware that there are some refrigerant collection devices which do not have self-certification.

### 13.3.2 Tools for R32 (common with R410A)

#### 1. Flare gauges

Use flare gauges when you perform flaring with flare tools (crutch type). Flare gauges are used to set the pipe ends at 0.5 ~ 1.5 mm from clump bars of flare tools.

Flare gauges



#### 2. Flare tools (clutch type)

Flare tools have larger holes of clump bars in order to set the pipe end at 0 ~ 0.5 mm, and have stronger springs inside to ensure solid flaring torques. These flare tools can be used commonly for R22.

Flare tools (clutch type)



### 3. Torque wrenches (diameters 1/2, 5/8)

In order to strengthen the compressive strength, the diameters of wrenches change depending on the flare nut sizes.

#### Torque wrenches

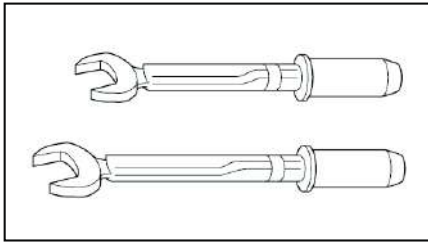

#### Differences in torque wrenches

	R32 (common R410A)	R22
1/2 (diameter × torque)	26 mm × 55 N•m (550 kgf•cm)	24 mm × 55 N•m (550 kgf•cm)
5/8 (diameter × torque)	29 mm × 65 N•m (650 kgf•cm)	27 mm × 65 N•m (650 kgf•cm)

### 4. Manifold gauges

R22 gauges cannot be used because of the high pressures.

Each port of manifold has different shapes in order to prevent inserting wrong refrigerant.

\*However, the port shape for R410A and R32 is the same; therefore, attention need to be paid not to insert wrong refrigerant.

#### Differences in high/low pressure gauges

	R32 (common R410A)	R22
High pressure gauges (red)	-0.1 ~ 5.3 MPa -76 cmHg ~ 53 kgf / cm <sup>2</sup>	-76 cmHg ~ 35 kgf / cm <sup>2</sup>
Low pressure gauges (blue)	-0.1 ~ 3.8 MPa -76 cmHg ~ 38 kgf / cm <sup>2</sup>	-76 cmHg ~ 17 kgf / cm <sup>2</sup>

#### Difference in manifold port sizes

	R32 (common R410A)	R22
Port sizes	1/2 UNF20	7/16 UNF20

### 5. Charging hoses

The pressure resistance of charge hoses is increased. At the same time, the material is changed to HFC resistant, and the size of each manifold adopter is changed, as the port size of manifold gauge itself. Further, some hoses are with anti-gas pressure backflow valves placed near the adopters. (hoses with the valves recommended)

### Manifold gauges / Charging hoses

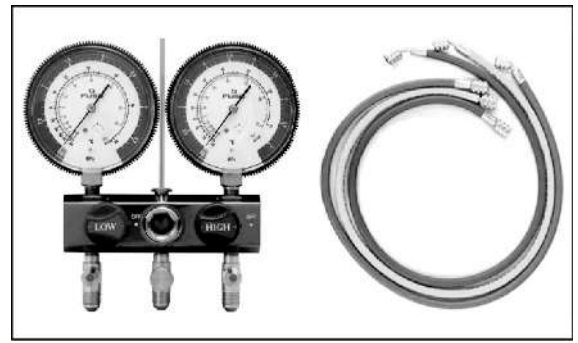

#### Differences in charging hoses

		R32 (common R410A)	R22
Pressure Resistance	Normal operation pressure	5.1 MPa (52 kgf / cm <sup>2</sup> )	3.4 MPa (35 kgf / cm <sup>2</sup> )
	Burst pressure	27.4 MPa (280 kgf / cm <sup>2</sup> )	17.2 MPa (175 kgf / cm <sup>2</sup> )
Material		HNBR rubber Internal nylon coating	NBR rubber

### 6. Vacuum pump and Vacuum pump adopter

When using a vacuum pump, it is necessary to set a solenoid valve in order to prevent backflow of vacuum pump oil into the charge hoses, and use a vacuum pump with oil backflow prevention function, or use the vacuum pump with vacuum pump adopter.

If vacuum pump oil ( mineral oil-based ) mixes with R410A (R32), it may cause damage to the machine.

#### Vacuum pump



#### Vacuum pump adopter



7. HFC refrigerant\_Electric gas leakage tester  
 R32 refrigerant is often used for other mixed refrigerant (R410A, R404A, R407C etc.). Therefore, the usage of existing HFC detectors is possible, but in order to detect more accurately, we recommend to use detectors specially set and adjusted for R32 detection.

HFC refrigerant\_Electric gas leakage tester



8. Digital scale for refrigerant charging  
 R32 and R410A have high pressure level and their evaporation speed is high. Thus, if you recover the refrigerant by cylinder charging method, the refrigerant evaporates within the weighing scale glass, which makes reading the scale difficult, rather than liquidating the refrigerant into the cylinder. (Charging cylinders for R22 have different pressure resistance, scale, connection port size; therefore, they are not usable) At the same time, the digital scale for refrigerant charging is strengthened by receiving the weight of the refrigerant cylinders with four pillars at the corners. The connection ports of charging hoses have two separate ports for R22 (7/16 UNF20) and R32/R410A (1/2 UNF20) therefore, they can be used for the insertion of the existing refrigerants.

Digital scale for refrigerant charging



9. Refrigerant cylinders  
 Refrigerant cylinders for R410A are painted in pink, and the ones for R32 are painted in other colors that might subject to change according to the international standards. R32 is a single refrigerant, so that both liquid and gas insertion are possible. Additional charging is also possible. (R410A is a mixed refrigerant, so only liquid insertion is possible)

Refrigerant cylinders



10. Connection ports of refrigerant cylinders and packing  
 Charging ports which fit to the charging hose connection port size (1/2 UNF20) is needed. At the same time, the packing has to be of HFC resistant materials.

Connection ports and packing



11. Tools used for refrigerant piping installations and services

	Tools for R410A	Common with R32	Possibility of usage for R22
1.	Pipe cutters, reamers or scrapers	○	○
2.	Flare tools (clutch type)	○	○
3.	Torque wrench (1/4, 3/8)	○	○
4.	Torque wrench (1/2, 5/8)	○	✕
5.	Manifold gauges · charging hoses	○	✕
6.	Vacuum pumps, vacuum pump adopters	○ Connection 5/16	○ Connection 1/4
7.	Electric gas leakage testers for HFC *1	○	△
8.	Digital scale for refrigerant charging	○	○
9.	HCF recovery devices (connection port 5/16) *2	○ Connection 5/16	○ Connection 1/4
10.	Refrigerant cylinders (pressure resistant: FC3)	Same specs ✕	✕
11.	Refrigerant cylinders (pink)	Other (colors that might subject to change according to the international standards).	✕
12.	Refrigerant cylinder connection ports and packing	○	✕
13.	Allen wrench (4 mm) Electric knives	○	○
*1	Those testers only for HCFC22 (R22), but not for HCF32 (R32) and HCF410A (R410A) cannot be for common use.		
*2	Recovery devices which are self-certified for each HCF type can be used.		
	<p>[Knowledge for the common usage of tools for R410A &amp; R32]</p> <ul style="list-style-type: none"> <li>• R410A and R32 machines use different compressor oils.</li> <li>• If unregulated compressor oil gets mixed into, it may cause damage to the machine function.</li> <li>• Careful pump down will ensure the recovery of compressor oil, and it will minimize the remaining amount of the oil in the manifold gauge and charging hose.</li> <li>• If you only perform the recovery of refrigerant and not be able to perform pump down, <u>you have to dispose the compressor oil in the charging hose.</u></li> </ul>		
	<p>[Precaution of repairing refrigerant cycle]</p> <ul style="list-style-type: none"> <li>• In the brazing, open 2-way and 3-way valves, and make sure the refrigerant is completely recovered back and not remaining the system.</li> <li>• When repairing outside, make sure no refrigerant is in the air, ensure good air flow, and perform the brazing.</li> </ul>		
	<p>[Inserting wrong refrigerant]</p> <ul style="list-style-type: none"> <li>• It may cause "not cooling" and "not heating" customer claims because each component (expansion valve, compressor, PCB) of the refrigeration cycle is specially adjusted for R32.</li> <li>• At the same time, it is not subject to product warranty, if wrong refrigerant was inserted into the system.</li> </ul>		

### 13.4 New installation, Relocation, Repairing of Refrigerant Cycle System The Procedures

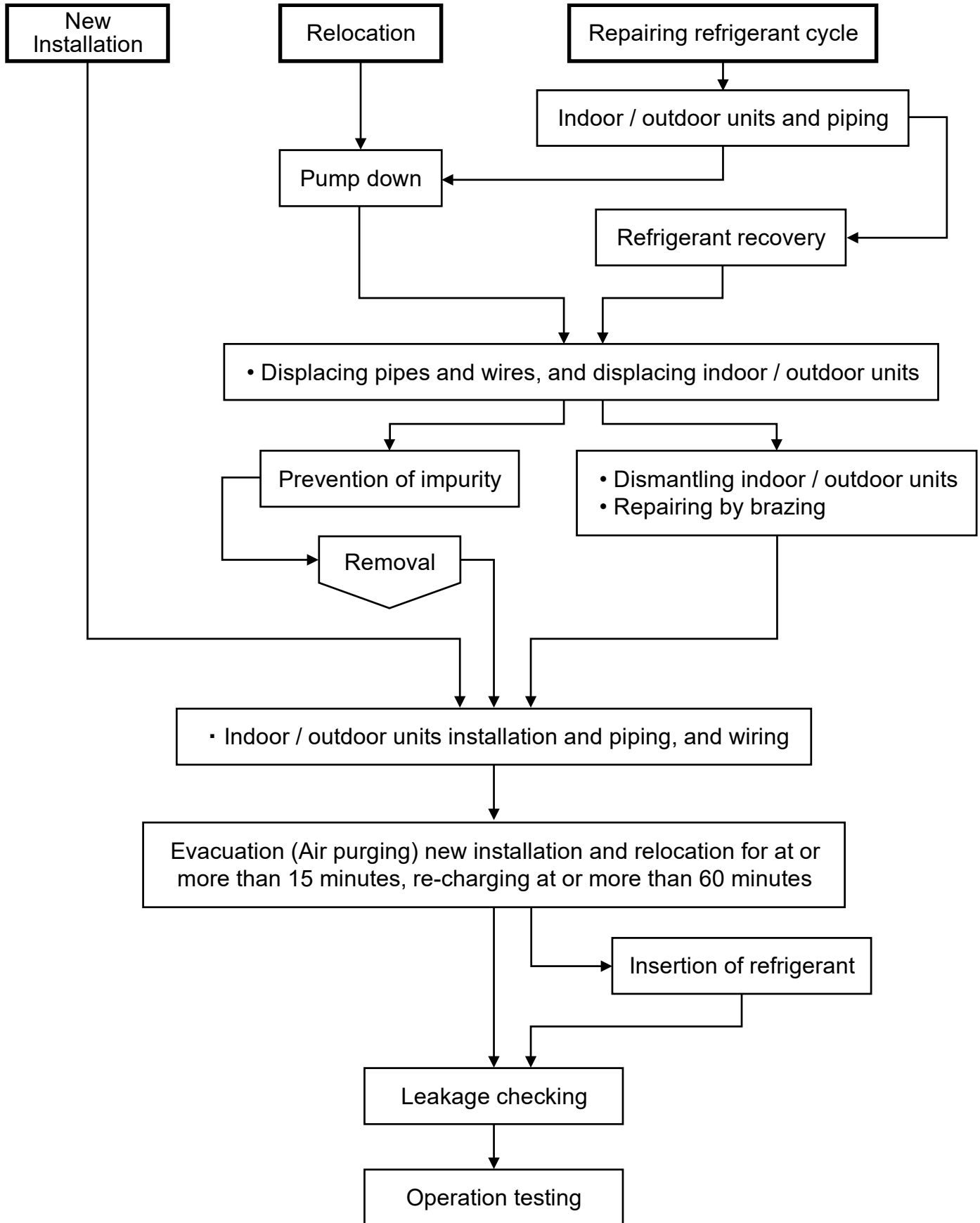

## 13.5 Piping installation of R32

### 13.5.1 Pipe materials used and flaring

Copper pipes are used for refrigerant piping. Pipes which comply with JIS Regulations need to be used. Room air conditioners which use R410A and R32 have higher pressure; thus, using pipes which comply with the Regulations is important.

The pipe thickness is regulated by revised JIS B 8607 "Flaring and brazing fittings for refrigerant" and the pipe thickness for R410A, R32 is shown in the table.

Pipe thickness

O and OL materials		Thickness (mm)		
Diameter	Diameter (mm)	R410A	R32	R22
1/4	6.35	0.80		
3/8	9.52	0.80		
1/2	12.70	0.80		
5/8	15.88	1.00		

#### Caution

- For connection piping, use copper phosphate seamless pipes (1220T) as regulated in "JIS H 3300" and the pipe thickness is 0.8 mm.
- In the market, there are some pipes of 0.7 mm thickness, but do not use these pipes (0.8 mm thickness has to be strictly followed).
- It is recommended to use pipes whose adhesion amount of oil is at or less than 40 mg / 10 m. At the same time, do not use pipes with dent, de-shape, and color change (especially inside).

### 13.5.2 Processing and connection of pipes

For refrigerant pipe installation, be aware of moisture and dirt do not get into the pipes, and make sure of no refrigerant leakage.

◎ The procedure of flaring and precautions

a) Cutting of pipes : use pipe cutter and cut the pipe slowly not to de-shape the pipe.

b) Removal of burrs on the edge of pipe (reamer or scraper)

If the condition of pipe edge after the deburring is no good or if burrs attaches on the flaring, it may cause refrigerant leakage. Turn the pipe end down and perform deburring carefully.

c) Insert the flare nut (use the nut which is a part of the CZ parts)

d) Flaring

Ensure the cleanliness of clump bar and pipe, and perform flaring carefully.

Use the existing flare tools or flare tools for R410A. Be aware that the sizes and dimensions of flaring is different in each flaring tool. If you use the existing flaring tools, use flaring gauge to measure the length of the flaring part.

Piping size (mm)	Dimensions "a" (mm) R22			Dimensions "a" (mm) R410A/R32		
	Flare tools		Flare tools for R410A	Flare tools		Flare tools for R410A
	Clutch type	Wing nut type	Clutch type	Clutch type	Wing nut type	Clutch type
6.35 (1/4")	0.5 ~ 1.0	1.0 ~ 1.5	0 ~ 0.5	1.0 ~ 1.5	1.5 ~ 2.0	0 ~ 0.5
9.52 (3/8")	0.5 ~ 1.0	1.0 ~ 1.5	0 ~ 0.5	1.0 ~ 1.5	1.5 ~ 2.0	0 ~ 0.5
12.70 (1/2")	0.5 ~ 1.0	1.5 ~ 2.0	0 ~ 0.5	1.0 ~ 1.5	2.0 ~ 2.5	0 ~ 0.5
15.88 (5/8")	0.5 ~ 1.0	1.5 ~ 2.0	0 ~ 0.5	1.0 ~ 1.5	2.0 ~ 2.5	0 ~ 0.5

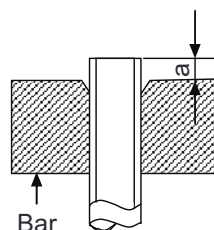

Nut outer diameter (mm)	
R22	R410A/R32
	R32
17	17
22	22
24	26
27	29



### 13.6.2 Process of refrigerant recovery

1. Connect the center charging hose of manifold gauge to the in-let side of recovery device.
2. Connect the valves of the discharge side of recovery device and liquid side of refrigerant cylinder with red hose (charging hose).
3. Connect the yellow float switch cable of the recovery device to the refrigerant cylinder.
4. Open the low pressure side valve of manifold gauge.
5. Insert electric plug of recovery device into electrical outlet (the fan operation starts).
6. Turn the valve 1 and 2 of recovery device to pressure equalization point.
7. After a few seconds, turn back the valve 1 and 2 to the original position.
8. Turn the switch of the recovery device to "ON". (the compressor operation starts)
9. When the low pressure of manifold gauge is close to "0", close the low pressure side valve, turn "OFF" the recovery device switch.
10. Remove the center charging hose of manifold gauge from the recovery device.

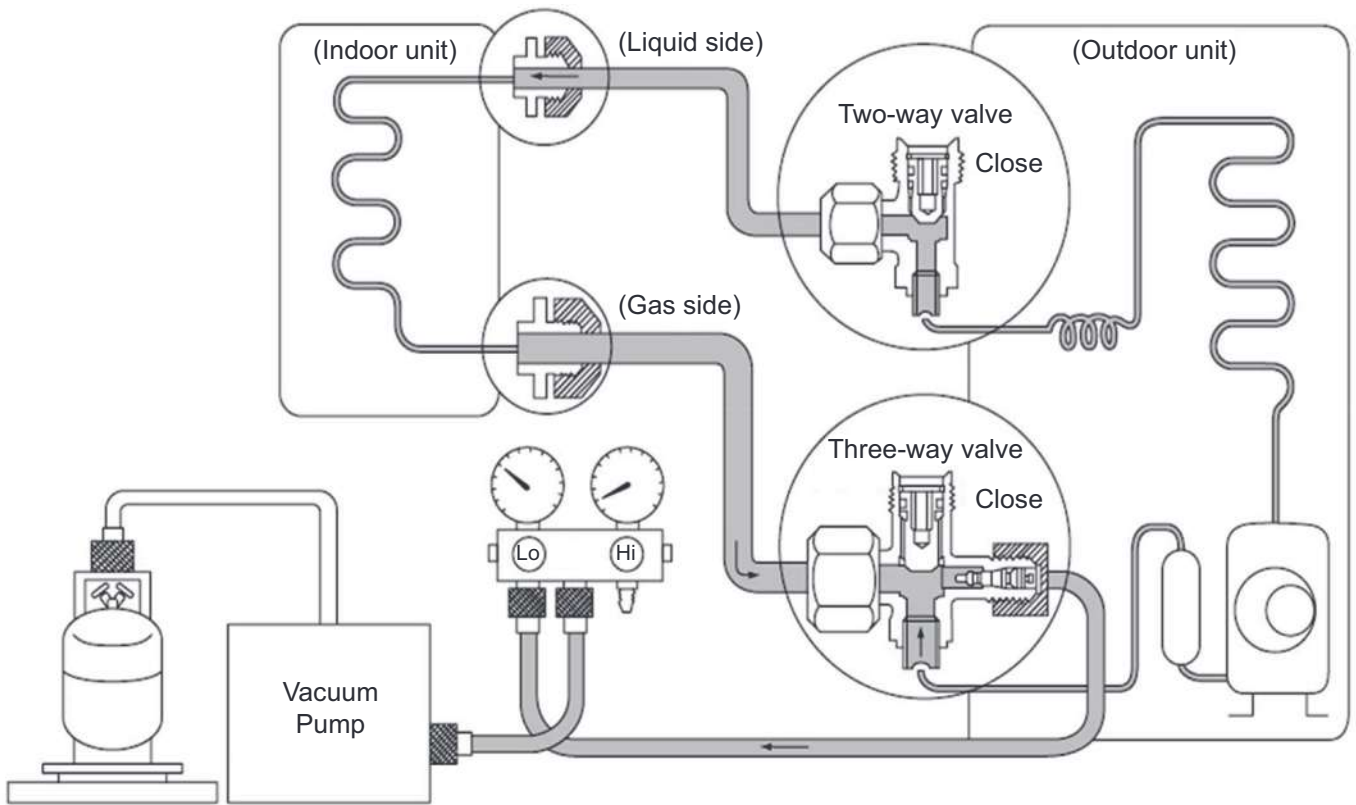

### 13.6.3 Relocation

#### 1. Removing the air conditioning unit

##### a) Recovery of outdoor unit refrigerant by pumping down

Press “forced cooling button” (as a general rule, since 1998 the name of cooling testing button is changed, and this name is unified within the air conditioning industry), and then you are able to start cooling operation in which the room temperature is low, and you can recover the refrigerant from the outdoor unit.

1. Check the valve stems of two-way and three-way valves are open by being turned to anti-clockwise (Remove the caps, and confirm the bars are fully open. Use hexagon wrench <4 mm> to open and close the valves).
2. Press the “Emergency Operation” button of the indoor units for five seconds and release [Forced cooling operation] (for old models, press “forced cooling” button). Then, operate the air conditioning unit for about 10 minutes.
3. Turn the stem of the two-way valve to the clock-wise and close the valve.
4. After about 2 ~ 3 minutes, turn the stem of the three-way valve quickly to the clock-wise, and stop the operation.

**Caution:** In the pump down operation, stop the compressor before removing the refrigerant pipes.

If you do not stop the compressor operation, and if the valve is open and remove the refrigerant pipes, the air may be sucked into the system and causes extreme high temperature in the refrigerant cycle. This may result in rupture or injury, etc.

5. Attach and tighten the caps of two-way and three-way valves with torque wrench.
6. Remove the connecting pipes (liquid side and gas side).

##### b) Removal of indoor and outdoor units

1. Remove the connecting pipes and wires between the indoor and outdoor units.
2. Attach capping flare nuts on the edges of the pipes, connecting the indoor and outdoor units, in order to prevent dust and moisture get into the pipes.
3. Remove the indoor and outdoor units.

#### 2. Unit installation

Use new refrigerant pipes for the installation, and perform air purging using vacuum pump and gas leakage testing stated in 13.5.1.

### 13.6.4 Replacement of air conditioning units and evacuation (when re-using the existing pipes)

When replacing the air conditioning units, you might use the existing pipes, but it is recommended to perform flaring again. In case of unit replacement, even if the unit is new refrigerant air conditioner, if the refrigerant oil is different, it may cause problem. Further, when re-using the existing refrigerant pipes, it is recommended to evacuate the pipes as much as possible, due to the reason that much refrigerant oil may be attached on the surface of the pipes. If the pipes are used without evacuation, the remaining refrigerant oil may cause under-performance and abnormal refrigerant cycle caused by non-compatibility of those oils.

### 13.6.5 Inter-changeability of refrigerant

Do not operate air conditioning units inserting wrong (or mixed) refrigerant (R22, R410A, R32). It may cause malfunction of the units, and at the same time, may cause serious incident such as rupture of the refrigerant cycle.

### 13.6.6 Re-insertion of refrigerant in service

When re-insertion is needed, follow the procedures to ensure the insertion of new refrigerant at correct amount.

1. Attach charging hose (blue) to the service port of the outdoor unit.
2. Attach charging hose (red) to the vacuum pump. Fully open the 2-way and 3-way valves.
3. Place the refrigerant cylinder on the digital scale for refrigerant charging and connect the charge hose (yellow) to the connection port of the vacuum pump and the digital scale. Leave the cylinder valve fully open.
4. Fully open the handles Lo and Hi of the manifold gauge, and switch on the vacuum pump, and then perform evacuation for at or more than one hour.
5. Confirm the compound gauge of -0.1 MPa (-76cmHg) and fully open the handles of Lo and Hi, and switch off the vacuum pump. Leave it for about 1 ~ 2 minutes and confirm the needle of the compound gauge does not turn back.

Refer to the picture below to follow the procedures below.

6. Remove the charging hose (red) of the manifold gauge from the vacuum pump adaptor.
7. After adjusting the digital scale to zero, open the cylinder valve and the valve Lo of the manifold gauge, and insert the refrigerant.
8. If it is not possible to insert the refrigerant at regulated amount at once, operate the cooling mode and gradually insert the refrigerant (recommended amount approx. 150 g / 1 time)  
\*Do not insert much refrigerant at once.
9. Close the open/close valve and insert the refrigerant in the charging hose to the outdoor unit.  
\*Perform this procedure during operating cooling operation. Close the stem of the two-way valve, and when the pressure of the manifold gauge becomes zero (0), quickly remove the charging hose (blue). Immediately open the 2-way valve, and stop the cooling operation.
10. Final checking • • • Confirm the 2-way and 3-way valves are fully open.  
Attach the caps of the service port and control valve, and then check the gas leakage around the caps.

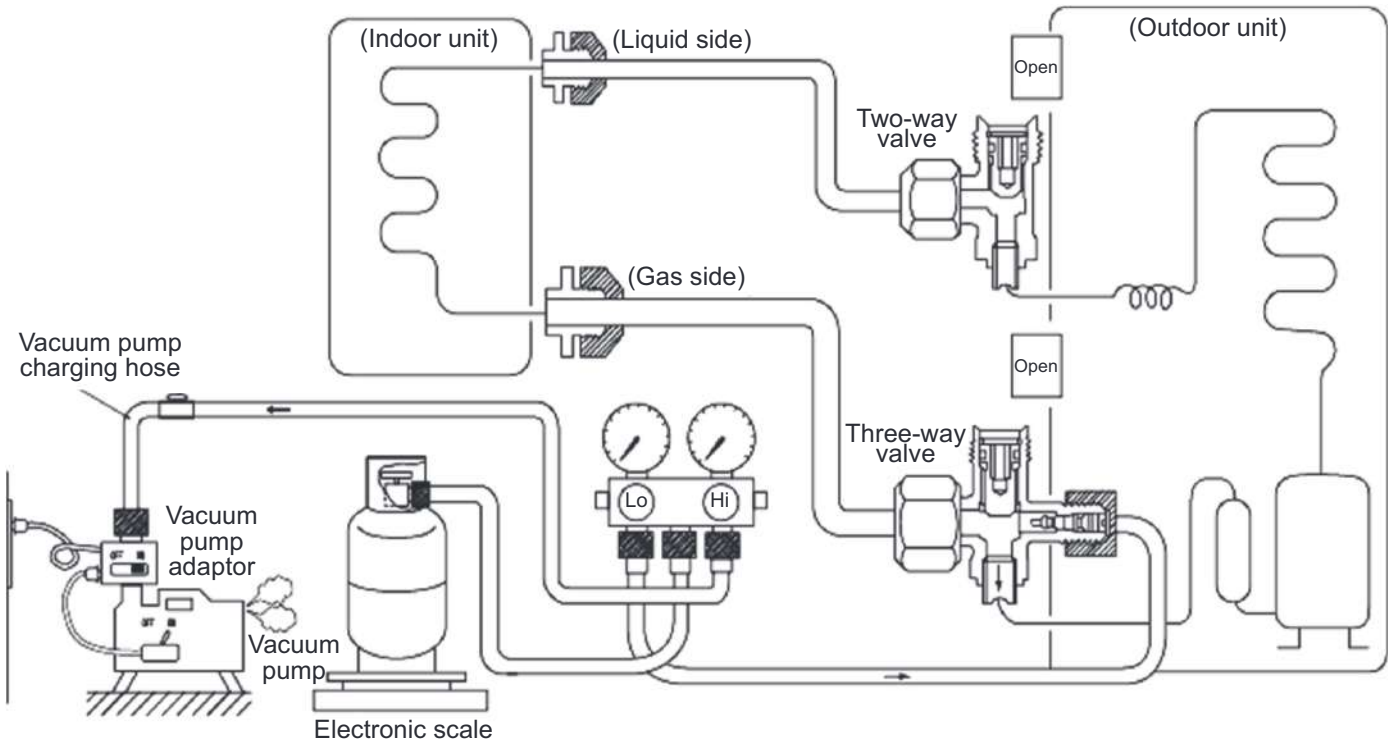

## 13.7 Repairing of refrigerant cycle / Brazing point

### 13.7.1 Preparation for repairing of refrigerant cycle / brazing

Brazing which is a technique needed for repairing refrigerant cycle requires advanced technique and experience, and this brazing procedure can only be performed by the workers who completed "Gas Welding Skill Training" regulated by the Occupational Safety and Health Act, and went through the training programs of refrigerant operations. Dismantling and re-connecting (assembling) refrigerant system requires working space, and the space has to ensure good air flow and fire prevention (water bucket and fire extinguisher). Moreover, the worker has to ensure the wearing of goggles, grabs, safety shoes, and long sleeve shirts, and be aware of work safety and attempt to prevent secondary defect (quality assurance of products). For brazing the indoor / outdoor unit structural components (heat exchangers, compressors, expansion valves, four-way valve blocks), after the recovery of all refrigerant, confirm that no refrigerant remains in the system, and fully open the 2-way and 3-way valves. When the brazing is conducted outside, check and make sure no refrigerant is contained in the air (be careful with vaporized refrigerant). Furthermore, protect the compressor terminal with metal plates, and heat but use wet clothes to cool down (releasing the heat) the expansion valves, and four way valves (prevent destruction of parts). In brazing, it is important to pour the brazing material without melting the base metal based on capillary action principle. In case of holes and oxidizing caused by overheating, do not perform re-brazing or alteration but replace the parts.

### 13.7.2 Adjustment of vacuum pump pressure

#### 1. Cylinder with adjustment handle

1. Check and confirm the adjustment handle of the 1<sup>st</sup> pressure adjuster is loosen (anticlockwise). If cylinder valve is opened when the 1<sup>st</sup> gauge pressure adjust handle is closed, the 2<sup>nd</sup> gauge might get broken.

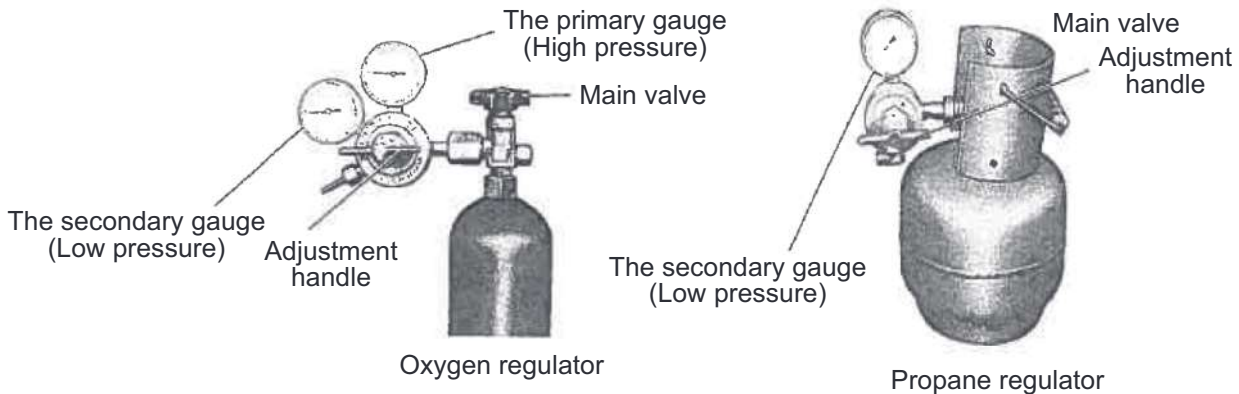

2. Open the cylinder valve, and check the remaining amount with the first side pressure gauge.
3. Check the pressure of 2<sup>nd</sup> gauge and turn the adjustment handle to clock-wise direction to adjust the pressure.
  - ⊙ Oxygen 2<sup>nd</sup> side gauge pressure . . . . . 0.5 MPa (5.0 kgf / cm<sup>2</sup>)
  - ⊙ Propane 2<sup>nd</sup> side gauge pressure . . . . . 0.05 MPa (0.5 kgf / cm<sup>2</sup>)

2. Cylinder without adjustment valve  
 2<sup>nd</sup> side gauge pressure is adjusted by the adjuster.  
 Check the both side valves of the torch and open the cylinder valve to check the remaining refrigerant in the cylinder.  
 Caution: Do not attach oil component on the connection port of the adjuster.  
 Especially, use an oxygen cylinder adjuster which is no oil substance type. Do not dismantle or repair the adjuster and pressure gauge.

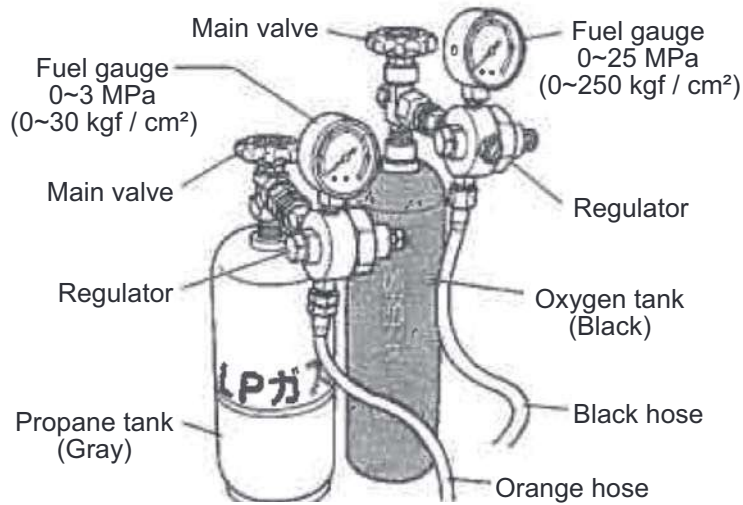

### 13.7.3 Checking of gas provision

Checking there is no fire around the torch, and then confirm the provision of gas.

1. Slightly open the “propane valve” of the torch, and make sure the gas comes out from the torch crater and then close the “propane valve”.
  2. Slightly open the “oxygen valve” of the torch and make sure the gas comes out from the torch crater and then close the “oxygen valve”.
- Check there is no gas leakage around the hose connection.

### 13.7.4 Adjustment of flame

1. Slightly open the “propane valve” of the torch and lit with spark lighter.  
 This moment, the flame is only by propane and the color is red.
2. Gradually open the “oxygen valve” of the torch to mix oxygen, and adjust the amount of propane and oxygen with the valve to make the flame suitable for brazing work.  
 If the white core flame splits into two, the torch crater might be clogged. In this case, remove the crater from the torch and check.

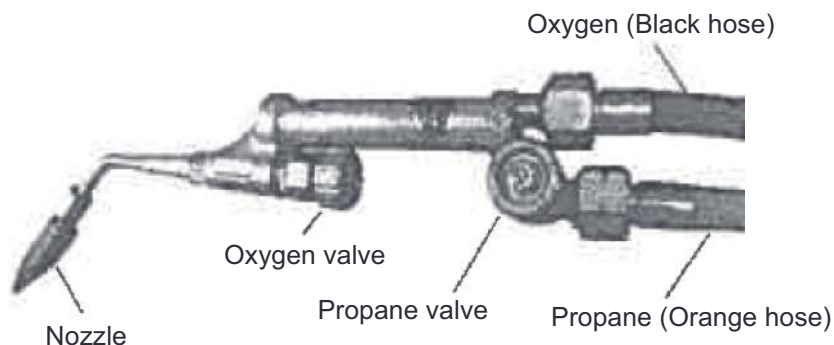

### 13.7.5 Types of flame

Types of flame change based on the proportion of propane and oxygen.

#### [Neutral Flame]

Perform brazing with this flame

(This is a flame when oxygen and propane are mixed at proper proportion, and has lesser effect on the brazed metals)

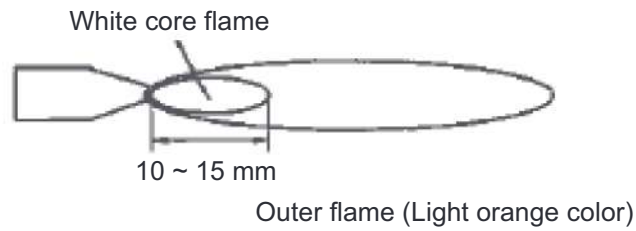

#### [Carbide Flame]

When propane is excessive, the flame has white color flame in between the white core flame and outer flame.

(This is due to the lack of oxygen and the proportion of unburned propane is excessive. The black carbon created during the brazing work may contaminate the surface of the brazed metal).

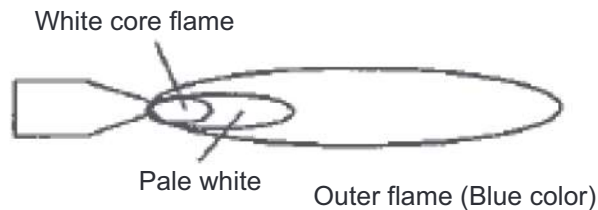

#### [Oxidizing Flame]

Oxygen is more compared to the neutral flame. Although the flame size is small, this has the highest flame heat. However, due to the excessive oxygen contained in the flame, the brazing point gets oxidized. (This flame may cause holes, due to the high heat. The pipe may get melt)

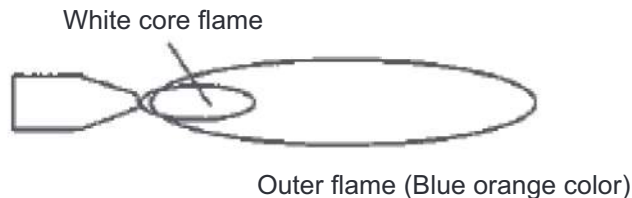

### 13.7.6 Closing the flame

#### [In case of short break]

1. Close the "propane valve" of the torch.
2. Close the "oxygen valve" of the torch.

#### [In case of finishing work]

1. As above, close the flame following the procedure of "In case of short break".
2. Completely close the valves of oxygen and propane cylinders.
3. Release the remaining gas inside the hose by opening the "oxygen valve" and "propane valve" of the torch. Confirm the 1<sup>st</sup> and 2<sup>nd</sup> side gauge pressures of "oxygen" and "propane" cylinder pressure adopter are "zero".

### 13.7.7 Selection of brazing material

Use BAg brazing material (silver solder) to increase the welding performance.

Category	JIS Standard Number	Composition of ingredients (%)						Temperature (°C)			Tensile strength (Reference)		Characteristics and applications
		Ag	Cu	Zu	Cd	Ni	P	Solidus	Liquidus	Brazing temp	Kgf•cm <sup>2</sup>	Base material	
BAg	BAg • 1A	49.0 ~ 51.0	14.5 ~ 16.5	14.5 ~ 18.5	17.0 ~ 19.0	—	—	approx. 625	approx. 635	635 ~ 760	45.5	S20C	Liquidity is good at low temperature, it is preferable to a small junction of the gap in the universal form.
	BAg • 1	44.0 ~ 56.0	14.0 ~ 16.0	14.0 ~ 18.0	23.0 ~ 25.0	—	—	approx. 605	approx. 620	620 ~ 760	45.5	S20C	It has similar performance to the BAg • 1A, and suitable for every base material except the light weight metal.
	BAg • 2	34.0 ~ 36.0	25.0 ~ 27.0	19.0 ~ 23.0	17.0 ~ 19.0	—	—	approx. 605	approx. 700	700 ~ 845	45.5	S20C	It is a brazing filler metal in universal form, suitable for a slightly larger gap junction.
	BAg • 3	48.0 ~ 51.0	14.5 ~ 16.5	13.5 ~ 17.5	15.0 ~ 17.0	2.5 ~ 3.5	—	approx. 630	approx. 690	690 ~ 815	35 ~ 70	SS ~ SUS	It has good corrosion resistance in stainless steel-based brazing, suitable for brazing tungsten carbide, aluminum bronze and copper.
BCuP	BCuP-2	—	remain	—	—	—	6.8 ~ 7.5	approx. 710	approx. 785	690 ~ 815	21 ~ 24.5	Cu	Good liquidity, suitable for brazing copper tube.
	BCuP-3	4.8 ~ 5.2	remain	—	—	—	5.8 ~ 6.7	approx. 645	approx. 815	720 ~ 815	21 ~ 24.5	Cu	Suitable for brazing when the joint spacing is not constant
	BCuP-5	14.5 ~ 15.5	remain	—	—	—	4.8 ~ 5.3	approx. 645	approx. 800	705 ~ 815	21 ~ 24.5	Cu	When brazing of copper and copper, it is used without a flux, but not possible for brazing basic materials

#### Caution

BCuP (phosphorus copper wax) is easy to react with sulfur, and makes a brittle compound water soluble, and causes gas leakage. In hot spring areas, use other brazing materials or paint the surface for protection.

### 13.7.8 Need of flux

**Use flux to protect the base materials.**

1. Remove impurity and oxide film on the metal base, and improve the flow of the brazing material.
2. Prevent oxidation of the metal surface in brazing.
3. Reduce the surface tension of the brazing material.

### 13.7.9 Need of nitrogen gas

In order to prevent oxidation in the pipe, perform the brazing operation in nitrogen gas flow. Flow rate 0.05 m<sup>3</sup> / h, or pressure reducing valve at 0.02 MPa (0.2kgf / cm<sup>2</sup>) below.

### 13.7.10 Checking of brazing (insert) points

1. No impurity on the brazing point  
If dirt or oil is attached on the brazing point, the brazing filler metal does not reach to junction, and it may cause poor welding.
2. Adequate gap space in the brazing point  
The advantage of capillary current situation is used in brazing. If the gap space is too large, this phenomenon may not occur and it may cause poor welding because brazing filler metal does not flow to join the front part.
3. Appropriate size for insertion  
The guideline for pipe insertion dimensions is to three times the diameter of the base material, but you need to decide the insertion size in consideration of the clogging of the brazing material. Generally, for thin pipes, you need to increase the insert size, and for thick pipe vice versa.
4. Brazing material to flow from top to bottom  
Brazing filler metal will easily flow to the connecting portion by capillary action. Further, by bending the brazing portion of [dryer side] of the capillary tube at 120°, you can prevent the damage of dryer inside and the clogging of brazing material caused by the excessive insertion of capillary tube.

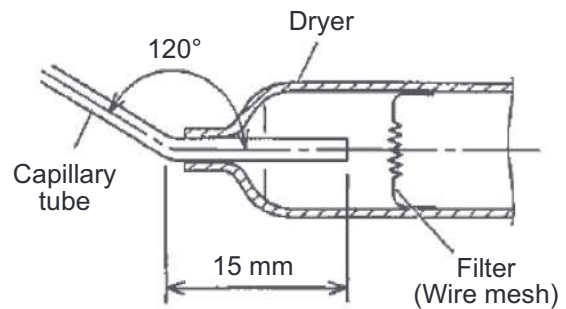
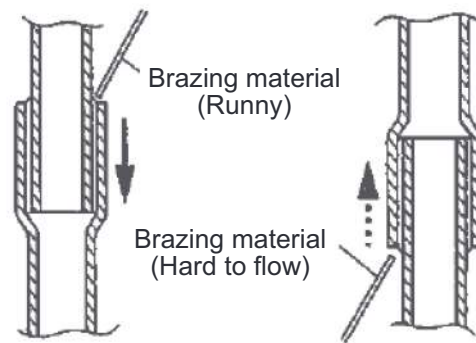
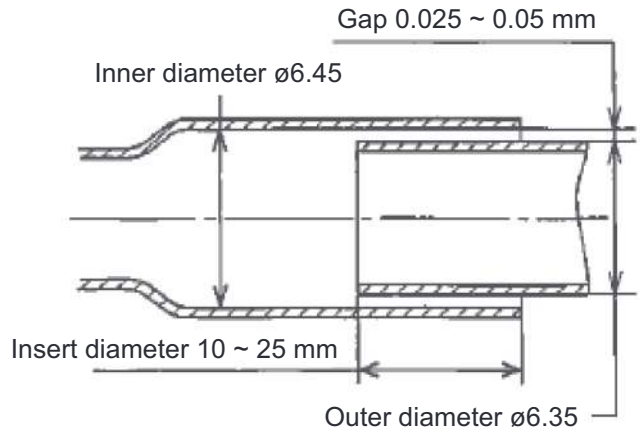

### 13.7.11 Brazing and heating

1. Place the flame to a pipe which has more heat capacity in order to let the brazing material melt by the pipe heat. Heat the pipe up to the melting temperature of the brazing material, but when it is overheating, assess the temperature by pipe color in order not to melt the pipe.

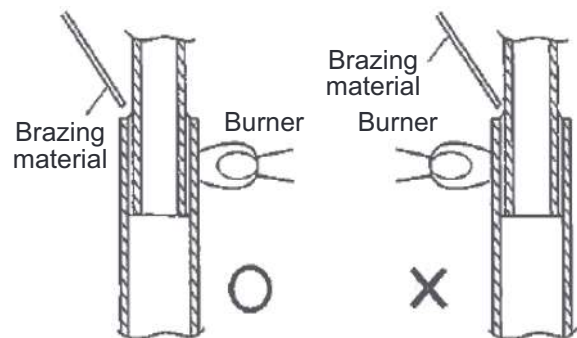

The pre-heating is to heat the base material until the melting temperature, and requires certain training to distinguish the color of the heated base material in order not to melt the material.

- The color and temperature of copper tube
- Becoming red color •••••••• 480°C
  - Dull red •••••••• 650°C
  - Cherish red •••••••• 760°C
  - Brightening cherish red •••••••• 870°C

(Reference)

Melting temperature of copper ••••••• Approx. 1083°C

Maximum temperature obtained in propane and oxygen ••••••• Approx. 1083°C

The important point is to heat the bonding part uniformly within a short period of time until reaching to the brazing temperature in the following manner.

2. Apply the flame on to the side with better heat transmission. If the pipe thickness is consistent, by heating like 30% iron and 70% copper, the copper pipe inside reaches to brazing temperature. Iron pipes have low heat transmission and only the part the flame is applied get high temperature, and this causes oxidization of the pipe. The flow of the brazing filler is affected negatively.
3. Apply the flame on to the side of larger heat capacity.  
When brazing a thin tubes such as capillary tube and dryer, etc., caution has to be taken to apply the flame to the dryer side (thick pipe side), in order to prevent burn out by the heat.
4. When brazing the compressor connection pipes (suction and discharge), remove the sound insulation plate and the fan, and place the compressor stand vertically (to prevent the leakage of compressor refrigerating machine oil), and apply the flame from the compressor body side.

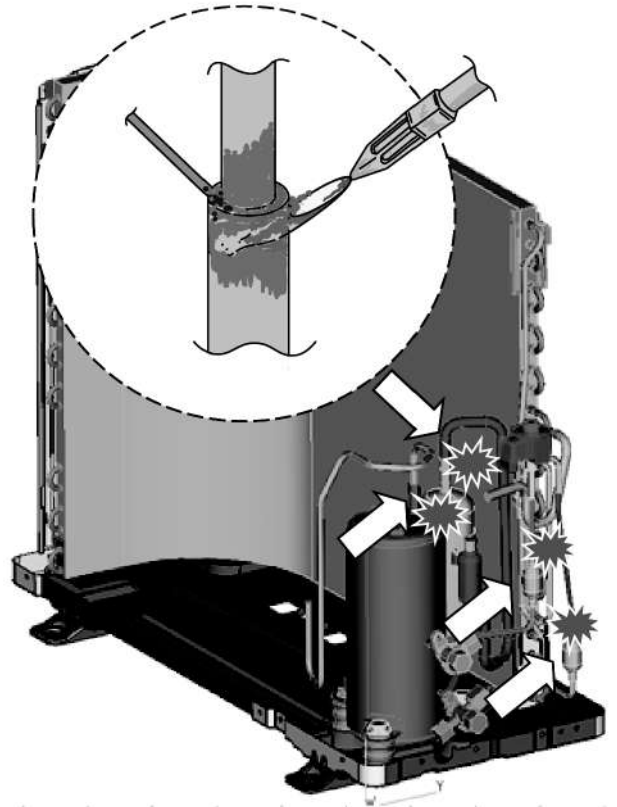

### 13.7.12 Terminologies of brazing

Pin holes → Small holes are generated on the surface of the brazing metal.

Wet temperature → Liquidus temperature at which the brazing material starts flowing out by heating, generally it is the liquidus-line temperature.

Blow holes → Hollows made by gas in the brazing material of brazing portion (gas reservoirs).

Pits → As a result of blow holes, small dents generated on the outside surface of welding.

Voids → The brazing material does not reach completely to the brazing part. It cannot be identified from outside.

## 13.8 <Reference> Analysis method for no error code, no cooling / no warming

### 13.8.1 Preparation for appropriate diagnosis

In order to obtain appropriate operation characteristics, minimum 15 minutes or more operation time [testing operation (rated operation)] is required.

#### 1. Method of rated operation (rated operation)

For the models which have two buttons of "emergency operation and forced cooling operation", press forced cooling button once. For the models which have only emergency operation button, press the button once for 5 seconds and when hear "beep" sound, release the button. Then, cooling operation starts.

#### 2. Checking the mal-functions of indoor / outdoor units

- 1) Any obstacles against heat release and air suction? (short circuit)  
(Forget to remove the outdoor unit cover or fallen leaves blocking the outdoor unit)
- 2) Are the indoor unit air filters clean? (obstructing heat suction)
- 3) Is the setting temperature on the remote controller correct? (is the setting temperature set at lower/higher than the room temperature?)

### 13.8.2 Understanding and verification of refrigerant cycle

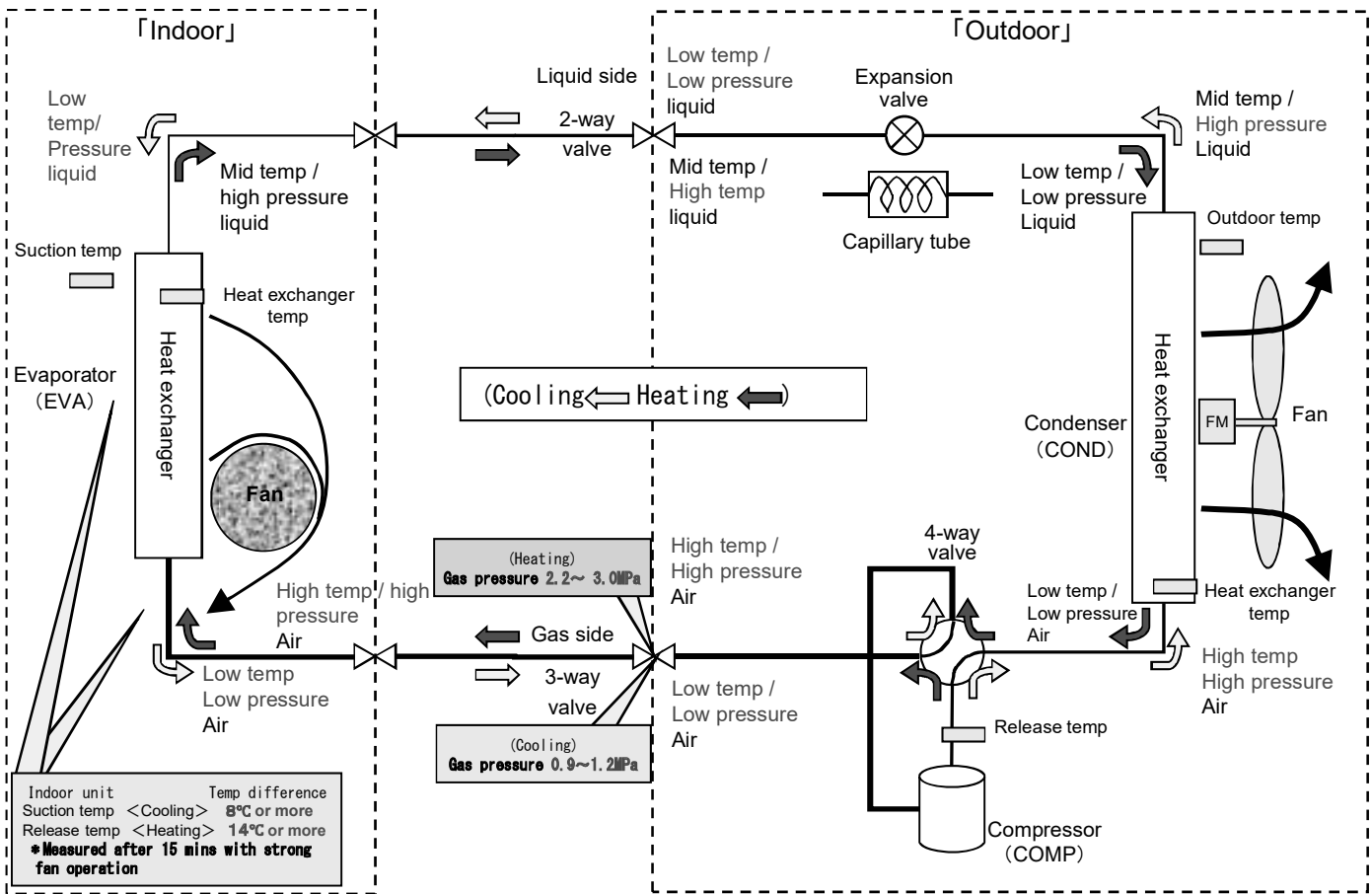

1. Measuring temperature
  - 1) Indoor unit suction temperature, release temperature, temperature difference, → Measure by thermometer
  - 2) 2-way valve pipe temperature in cooling mode is low temperature (benchmark : 5 ~ 10°C), in heating mode is medium temperature (benchmark : 25 ~ 35°C).
  - 3) 3-way valve pipe temperature in cooling mode is low temperature (benchmark : 7 ~ 15°C) in heating mode is high temperature (benchmark : 38 ~ 50°C).
2. Measuring electric current
  - Measuring electric current in operation → check by clamp meter (refer to table of technical characteristic guideline)
3. Measuring pressure
  - Measuring gas pressure → check the pressure by manifold gauge (refer to table of technical characteristic guideline)
4. Any sound from the expansion valve?  
(when starting the operation and the outdoor unit is turned on, the expansion valve is re-set, check if there is any edged sound or clack sound)

### 13.8.3 Guidance for diagnosis of refrigerant cycle

Comparison with normal operation	Cooling mode	
	High	Low
Refrigerant pressure	Excess insertion of refrigerant	Clogged capillary, expansion valve malfunction
	Heat releasing obstruction	Clog by moisture
	Dirty condenser, attachment of impurity	Lack of refrigerant gas
	Compressor malfunction	
Operation electric current	Excess insertion of refrigerant	Lack of refrigerant gas
	Heat releasing obstruction	Compressor malfunction
	Dirty condenser, impurity	Mixture of air
		(Insufficient evacuation)
2-way valve temperature	Excess insertion of refrigerant	Clogged capillary, expansion valve malfunction
	Compressor malfunction	Lack of refrigerant gas
3-way valve temperature	Lack of refrigerant gas • Compressor malfunction	Excess insertion of refrigerant
	Clogged capillary, expansion valve malfunction	

Suction temperature & Release air temperature	Temperature difference at or less than 8°C in cooling operation • • • Causes		
	• Heat releasing obstruction	• Dirty condenser	• Attachment of impurity
	• Lack of refrigerant gas	• Excess insertion of refrigerant	
	• Mixture of air	• Mixture of moisture	
	• Clogged capillary	• Expansion valve malfunction	• Compressor malfunction

◎ Above all are based on the condition that the installation work is properly performed (no issues in indoor / outdoor pipe connections, etc.)

## 14. Operation Control

### 14.1 Basic Function

Inverter control, which equipped with a microcomputer in determining the most suitable operating mode as time passes, automatically adjusts output power for maximum comfort always. In order to achieve the suitable operating mode, the microcomputer maintains the set temperature by measuring the temperature of the environment and performing temperature shifting. The compressor at outdoor unit is operating following the frequency instructed by the microcomputer at indoor unit that judging the condition according to internal setting temperature and intake air temperature.

#### 14.1.1 Internal Setting Temperature

Once the operation starts, remote control setting temperature will be taken as base value for temperature shifting processes. These shifting processes are depending on the air conditioner settings and the operation environment. The final shifted value will be used as internal setting temperature and it is updated continuously whenever the electrical power is supplied to the unit.

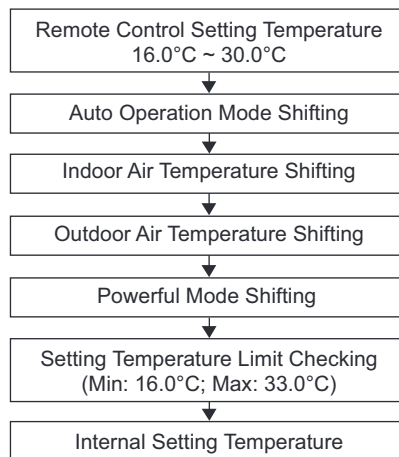

#### 14.1.2 Cooling Operation

##### 14.1.2.1 Thermostat control

- Compressor is OFF when Intake Air Temperature - Internal Setting Temperature  $< -1.5^{\circ}\text{C}$  continue for 3 minutes.
- When compressor is OFF (Thermostat OFF) and AUTO FAN is set, the fan will stop periodically.
- Compressor is ON after waiting for 3 minutes, if the Intake Air Temperature - Internal Setting Temperature  $>$  Compressor OFF point.

#### 14.1.3 Soft Dry Operation

##### 14.1.3.1 Thermostat control

- Compressor is OFF when Intake Air Temperature - Internal Setting Temperature  $< -2.0^{\circ}\text{C}$  continue for 3 minutes.
- When compressor is OFF (Thermostat OFF) and AUTO FAN is set, the fan will stop periodically.
- Compressor is ON after waiting for 3 minutes, if the Intake Air Temperature - Internal Setting Temperature  $>$  Compressor OFF point.

#### 14.1.4 Heating Operation

##### 14.1.4.1 Thermostat control

- Compressor is OFF when Intake Air Temperature - Internal Setting Temperature  $> *2.0^{\circ}\text{C}$  continue for 3 minutes.
- Compressor is ON after waiting for 3 minutes, if the Intake Air Temperature - Internal Setting Temperature  $<$  Compressor OFF point.

### 14.1.5 Automatic Operation

- This mode can be set using remote control and the operation is decided by remote control setting temperature, remote control operation mode and indoor intake air temperature.
- During operation mode judgment, indoor fan motor (with speed of Lo-) is running for 30 seconds to detect the indoor intake air temperature.
- Every 10 minutes, the indoor temperature is judged.
- For the 1st judgment
  - If indoor intake temperature - remote control setting temperature  $\geq 2.0^{\circ}\text{C}$ , COOL mode is decided.
  - If  $-2.0^{\circ}\text{C} \leq$  indoor intake temperature - remote control setting temperature  $< 2.0^{\circ}\text{C}$ , DRY mode is decided.
  - If indoor intake temperature - remote control setting temperature  $< -2.0^{\circ}\text{C}$ , HEAT mode is decided.

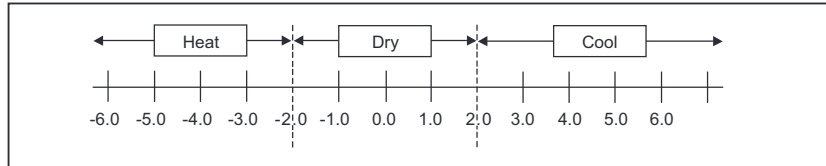

- For the 2nd judgment onwards
  - If indoor intake temperature - remote control setting temperature  $\geq 3.0^{\circ}\text{C}$ , if previous operate in DRY mode, then continue in DRY mode, otherwise COOL mode is decided.
  - If  $-2.0^{\circ}\text{C} \leq$  indoor intake temperature - remote control setting temperature  $< 3.0^{\circ}\text{C}$ , maintain with previous mode.
  - If indoor intake temperature - remote control setting temperature  $< -2.0^{\circ}\text{C}$ , HEAT mode is decided.

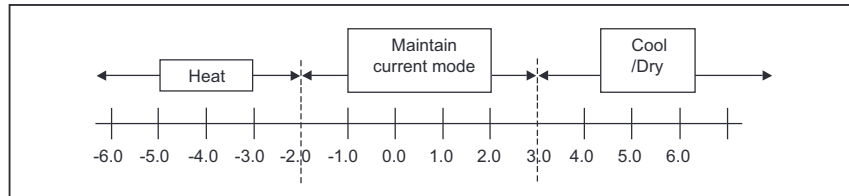

## 14.2 Indoor Fan Motor Operation

### 14.2.1 Basic Rotation Speed (rpm)

#### A. Basic Rotation Speed (rpm)

##### i. Manual Fan Speed

[Cooling, Dry]

- Fan motor's number of rotation is determined according to remote control setting.

Remote control	○	○	○	○	○
Tab	Hi	Me+	Me	Me-	Lo

- When thermostat off, the fan speed will be limited to max Me fan.
- The indoor fan will resume running according to the set fan speed when thermostat on.

[Heating]

- Fan motor's number of rotation is determined according to remote control setting.

Remote control	○	○	○	○	○
Tab	SHi	Me+	Me	Me-	Lo

ii Auto Fan Speed

[Cooling, Dry]

- According to room temperature and setting temperature, indoor fan speed is determined automatically.
- When set temperature is not achieved, the indoor fan will operate according to pattern below.

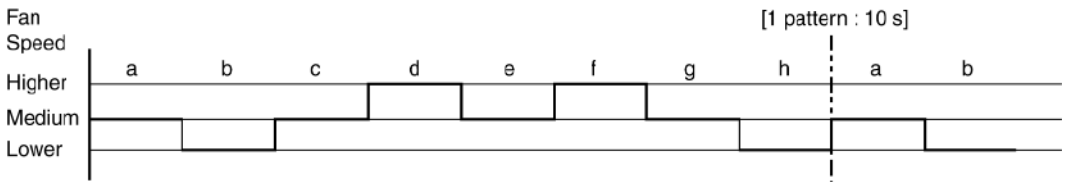

- When set temperature achieved, the indoor fan speed will be fixed. When thermostat off, the fan stop periodically.
- [Heating]

- According to indoor pipe temperature, automatic heating fan speed is determined as follows.

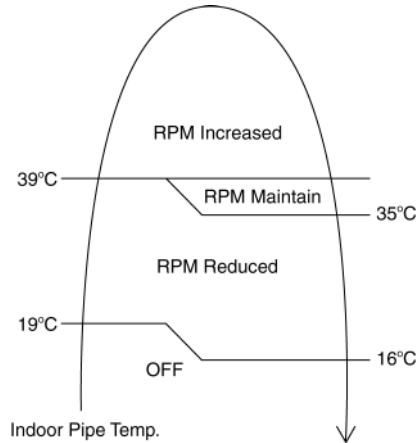

**B. Feedback control**

- Immediately after the fan motor started, feedback control is performed once every second.
- During fan motor on, if fan motor feedback  $\geq 2550$  rpm or  $< 50$  rpm continue for 10 seconds, then fan motor error counter increase, fan motor is then stop and restart. If the fan motor counter becomes 7 times, then H19 - fan motor error is detected. Operation stops and cannot on back.

**14.3 Outdoor Fan Motor Operation**

- It starts when compressor starts operation and it stops 30 seconds after compressor stops operation.

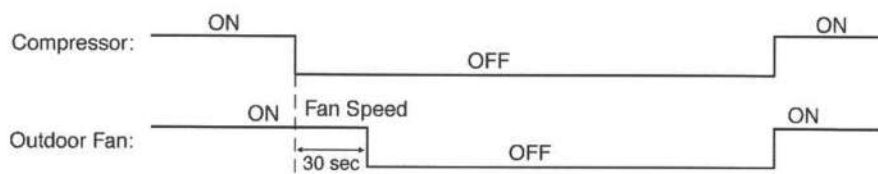

- During cooling operation, and outdoor ambient temperature is below 8°C, outdoor fan speed will be controlled according to outdoor piping temperature as following:

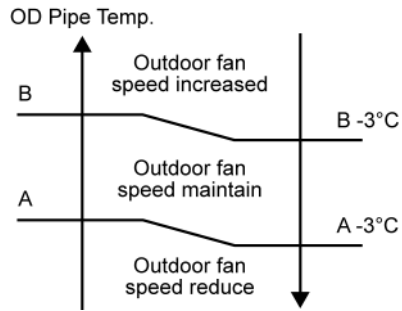

	OD Pipe Temperature
A	26°C
B	33°C

- During above condition, when indoor heat exchanger temperature is below 5°C, the outdoor fan will stop according to outdoor piping temperature as following:

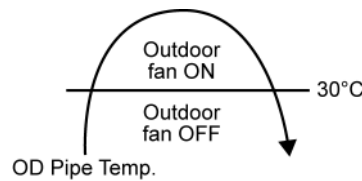

## 14.4 Airflow Direction

- There are two types of airflow, vertical airflow (directed by horizontal vane) and horizontal airflow (directed by vertical vanes).
- Control of airflow direction can be automatic (angles of direction is determined by operation mode, heat exchanger temperature and intake air temperature) and manual (angles of direction can be adjusted using remote control).

### 14.4.1 Vertical Airflow

Z25/35/42YKEA

Operation Mode	Airflow Direction		Inner Vane Angle (°)					Outer Vane Angle (°)				
			1	2	3	4	5	1	2	3	4	5
Cooling/Dry	Auto	Not yet achieve set temperature	7 ~ 40					4 ~ 45				
		Achieve set temperature	7					4				
	Auto Swing		7 ~ 40					4 ~ 45				
	Manual		7	15	20	30	40	4	14	25	34	45
Heating	Manual		15	20	35	50	56	19	25	34	43	49
	Auto	A	15					19				
		B	54					43				
		C	20					25				
	Auto Swing	Lower Evaporator Temperature Zone	15					19				
		Higher Evaporator Temperature Zone	20 ~ 56					25 ~ 49				

Operation Mode	Airflow Direction		Inner Vane Angle (°)					Outer Vane Angle (°)				
			1	2	3	4	5	1	2	3	4	5
Cooling/Dry	Auto	Not yet achieve set temperature	13 ~ 52					6 ~ 34				
		Achieve set temperature	13					6				
	Auto Swing		13 ~ 52					6 ~ 34				
	Manual		13	20	31	42	52	6	17	23	28	34
Heating	Manual		20	27	35	53	65	17	25	34	39	49
	Auto	A	20					17				
		B	35					34				
		C	20					17				
	Auto Swing	Lower Evaporator Temperature Zone	20					17				
		Higher Evaporator Temperature Zone	35 ~ 65					34 ~ 49				

- Automatic vertical airflow direction can be set using remote control; the vane swings up and down within the angles as stated above. For heating mode operation, the angle of the vane depends on the indoor heat exchanger temperature as Figure 1 below. It does not swing during fan motor stop. When the air conditioner is stopped using remote control, the vane will shift to close position.
- Manual vertical airflow direction can be set using remote control; the angles of the vane are as stated above and the positions of the vane are as Figure 2 below. When the air conditioner is stopped using remote control, the vane will shift to close position.
- If automatic control (AUTO) or automatic swing (AUTO SWING) vane is selected, the inputs of the control are: mode of operation, inlet temperature, and heat exchanger temperature.
- If manual vane is selected, the inputs are: Up-and-down vane actual signal.

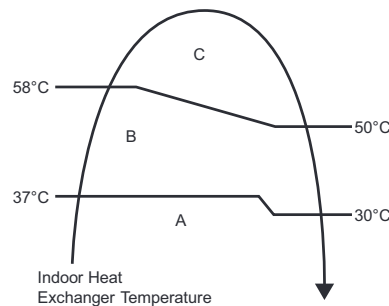
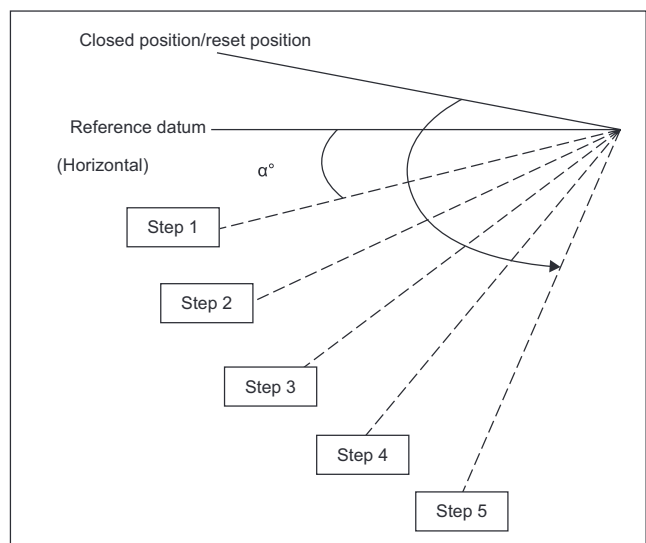
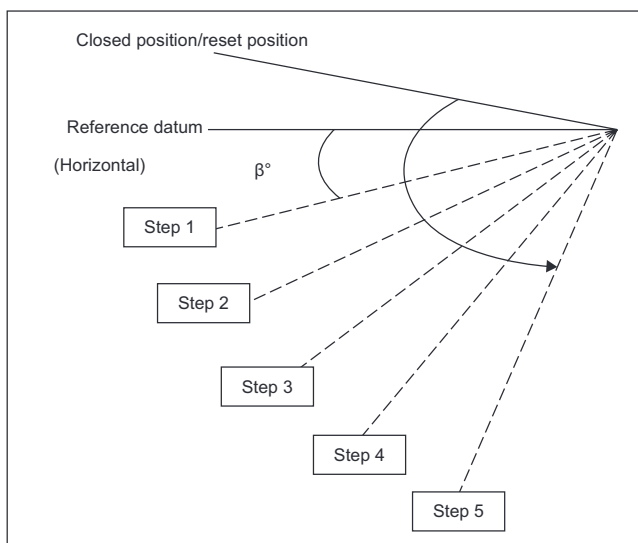
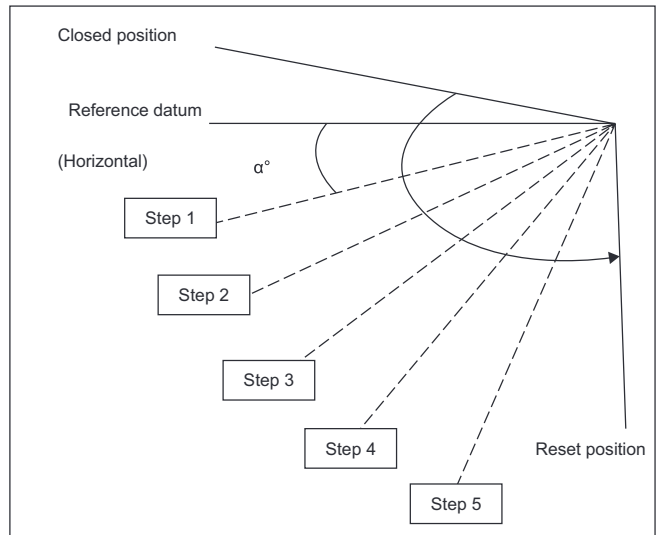
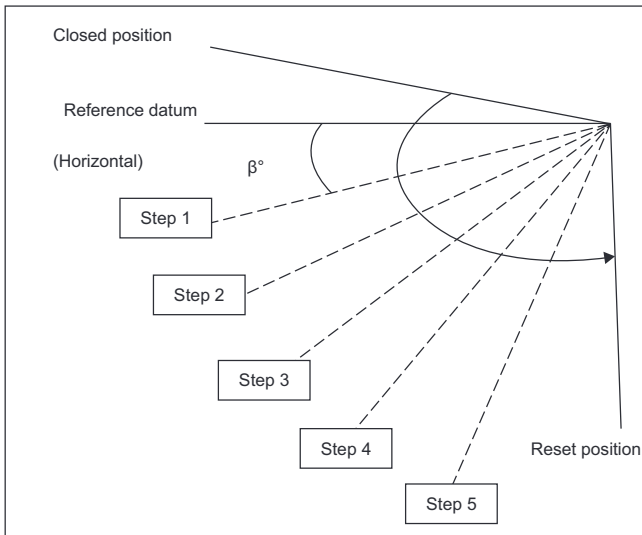

Figure 1

For Z25/35/42YKEA



**For Z50/71YKEA**



\* The horizontal vane angle tolerance is within +/- 5 degree.

**14.4.2 Horizontal Airflow**

- Automatic horizontal airflow direction can be set using remote control; the vane swings left and right within the angles as stated below. For heating mode operation, the angle of the vane depends on the indoor heat exchanger temperature as Figure 1 below. It does not swing during fan motor stop.

Operation Mode		Vane Angle (°)
Heating, with heat exchanger temperature	A	60 ~120
	B	90
Cooling and soft dry		60 ~120

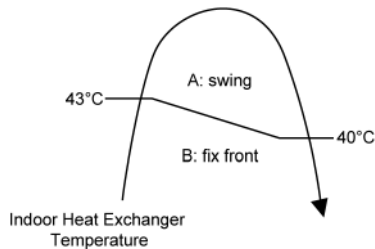

Figure 1

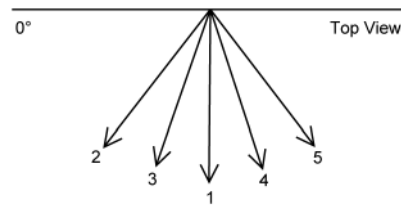



Figure 2

- Manual horizontal airflow direction can be set using remote control; the angles of the vane are as stated below and the positions of the vane are as Figure 2 above.



Pattern	1	2	3	4	5
Airflow Direction Patterns at Remote Control					
Vane Angle (°)	90	60	75	105	120

\* The vertical vane angle tolerance is within +/- 5 degree.



## 14.5 Quiet Operation (Cooling)

- Purpose
  - To provide quiet cooling operation compare to normal operation.
- Control condition
  - Quiet operation start condition
    - When  operation is selected.  will be shown on remote control display.
  - Quiet operation stop condition
    - Quiet is disable when fan speed is changed or Powerful is enable.
- When quiet operation is stopped, operation is shifted to normal operation with previous setting.
- When operation mode is change, quiet operation is shifted to quiet operation of the new mode.
- During quiet operation, if timer "ON" activates, quiet operation maintain.
- After OFF, when ON back, quiet operation is memorized.
- Control content
  - Fan speed is changed to QLo.

## 14.6 Quiet Operation (Heating)

- Purpose
  - To provide quiet heating operation compare to normal operation.
- Control condition
  - Quiet operation start condition
    - When  operation is selected.  will be shown on remote control display.
  - Quiet operation stop condition
    - Quiet is disable when fan speed is changed or Powerful is enable.
- When quiet operation is stopped, operation is shifted to normal operation with previous setting.
- When operation mode is change, quiet operation is shifted to quiet operation of the new mode.
- During quiet operation, if timer "ON" activates, quiet operation maintain.
- After OFF, when ON back, quiet operation is memorized.
- Control contents
  - Fan speed is changed to QLo.

## 14.7 Powerful Operation

- Purpose
  - To achieve the setting temperature quickly.
- Control condition
  - Powerful operation start condition
    - When  is selected.  Will be display on remote control display.
  - Powerful operation stop condition
    - Powerful operation will be disable after 20 minutes.
    - Powerful operation will be disable when fan speed is changed and Quiet operation is enable.
- Control contents
  - When powerful mode is selected, the internal setting temperature will shift lower up to 2°C (for Cooling) or higher up to 3.5°C (for heating) than remote control setting temperature for 20 minutes.

## 14.8 Weekly Timer

### Weekly timer

Select this icon to delete (cancel) or change the pre-set Weekly Timer.

**Press**  **to confirm your selection.**

When Weekly Timer mode is selected, an icon will appear on top left of remote control.

\* Refer to "Remote Controller buttons and display"

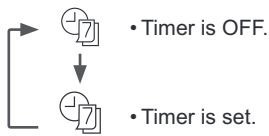

After 1 sec delay.

Do you want to edit Weekly timer pattern?

**Yes**  No

**Select "Yes".**

• If you select "No", the screen will return to the Main Screen.

**Timer setup**

Timer copy

• Timer setup: Select Timer setup to edit the Weekly Timer.

• Timer copy: Select to copy a timer setting.

Sun	Mon	Tue	Wed	Thu	Fri	Sat
✓	✓	✓	✓	✓	✓	✓

**[Example of a Timer setup]**



Select the day(s) which you wish to edit using   buttons.

All 6 patterns are not set!  
Do you want to edit?

Yes  **No**

If all 6 patterns are not preset, this screen will be displayed.

Weekly timer 12:00, Mon

	Sun	Mon	Tue	Wed	Thu	Fri	Sat
1.		6:00am		ON			25.0°C
2.		8:00am		ON			25.0°C
3.		10:00am		ON			25.0°C

①      ②      ③      ④      ⑤

① **Select pattern "1" ~ "6".**

② **Set the hour and minutes of the Timer.**

③ **Select ON/OFF of the Timer.**

④ **Select the operation mode.**



⑤ **Set the temperature.**

Stop Condition:

- ON/OFF button is pressed.

## 14.9 Auto Restart Control

- When the power supply is cut off during the operation of air conditioner, the compressor will re-operate within three to four minutes (there are 10 patterns between 2 minutes 58 seconds and 3 minutes 52 seconds to be selected randomly) after power supply resumes.
- This type of control is not applicable during ON/OFF Timer setting.
- This control can be omitted by open the circuit of JP1 at indoor unit printed circuit board.

## 14.10 Indication Panel

LED	POWER	TIMER	Wi-Fi
Color	White	White	White
Light ON	Operation ON	Timer Setting by Comfort Cloud	Wireless LAN Mode ON
Light OFF	Operation OFF	Other than above OFF	Wireless LAN Mode OFF

Note:

- If POWER LED is blinking, the possible operation of the unit are Hot Start, during Deice operation, operation mode judgment, or ON timer sampling.
- If Timer LED is blinking, there is an abnormality operation occurs.

## 14.11 WLAN Control

### 14.11.1 System Overview.

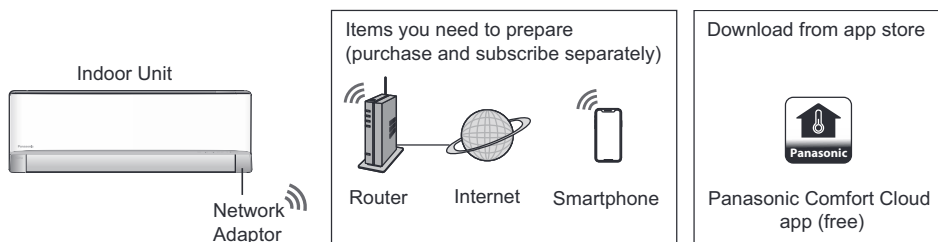

- Requires the APP to work with a smartphone with Android 5.0 and above, or iOS 9 and above. However, there is no guarantee that the APP will work well with all Android OS version.
- The Network Adaptor is designed specifically as a terminal for Panasonic Comfort Cloud app.
- The WLAN network coverage must reach the air conditioner installation location.

### Specification

Network Adaptor	WLAN Module (built-in)
Model	DNSK-P11
Input Voltage	DC 5V (From Air Conditioner Indoor Unit)
Current Consumption	Tx/Rx max. 290/100 mA
WLAN standard	IEEE 802.11 b/g/n
Frequency range	2.4 GHz band
Encryption	WPA2-PSK (TKIP/AES)

### Precaution

- Do NOT disassemble or alter this Network Adaptor in anyway.
- Do NOT remove this Network Adaptor from the appliance product's during operations.
- Data transmitted and received over radio waves may be intercepted and monitored.

### Maximum radio-frequency power transmitted in the frequency bands

Type of wireless	Frequency band	Max. EIRP (dBm)
WLAN	2412 - 2472 MHz	20 dBm

### 14.11.2 Connecting Network

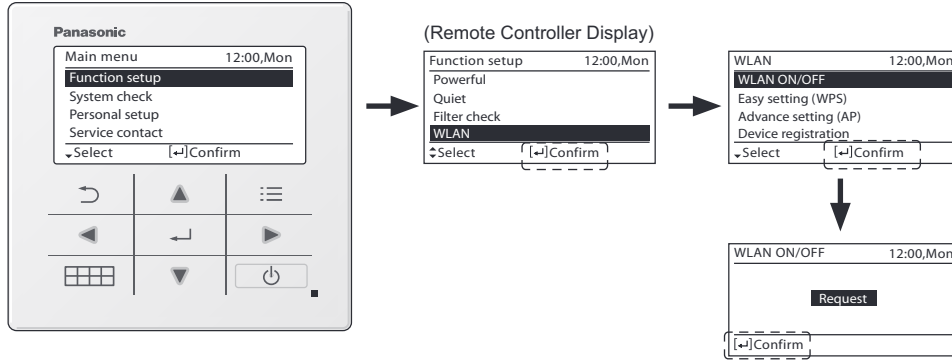

- Select Function Setup from remote controller Main Menu.



Fast blink	The unit is establishing the connection.
Slow blink	The unit is not securing the connection.
No blink (stays on)	The unit is has established the connection.

- It can establish the connection to the unit even If the unit turned OFF.

### 14.11.3 Application Installation

<p>For Android user (Android 5.0 and above)</p> <ul style="list-style-type: none"> <li>Open </li> <li>Search for Panasonic Comfort Cloud app.</li> <li>Download and install.</li> </ul>	<p>For iOS user (iOS 9 and above)</p> <ul style="list-style-type: none"> <li>Open </li> <li>Search for Panasonic Comfort Cloud app.</li> <li>Download and install.</li> </ul>
--	--

#### Note

- The app user interface image may change for version upgrade without notification.
- There is no charge for using this application. However, other charges may be incurred for connection and operation.

### 14.11.4 To Disconnect WLAN (Off WLAN LED)

- Select Function Setup from remote controller Main Menu.

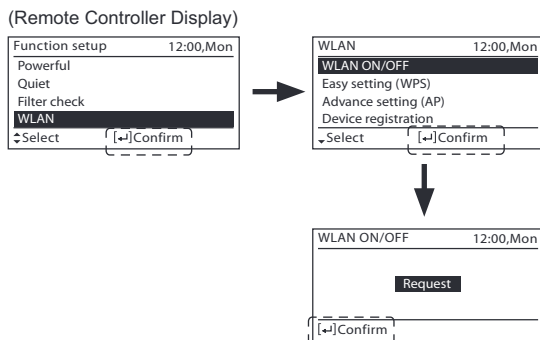

### 14.11.5 To Delete WLAN Information

- If WLAN is off (LED is OFF), turn on WLAN first.
- Select Function Setup from remote controller Main Menu.

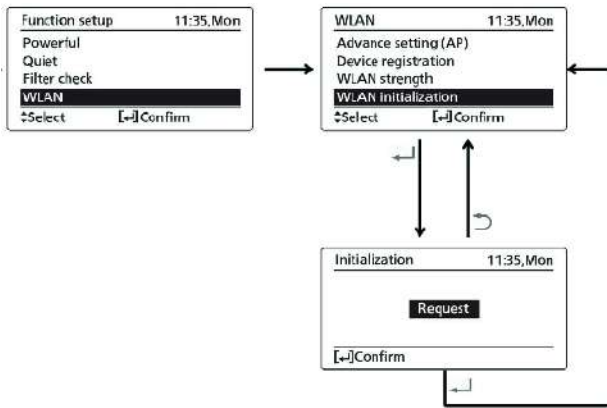

- When Initialization finish, WLAN LED will off automatically.

### 14.11.6 To Check WLAN Signal Strength

- Confirm the air conditioner operation is stopped and select Function setup from remote controller Main Menu.

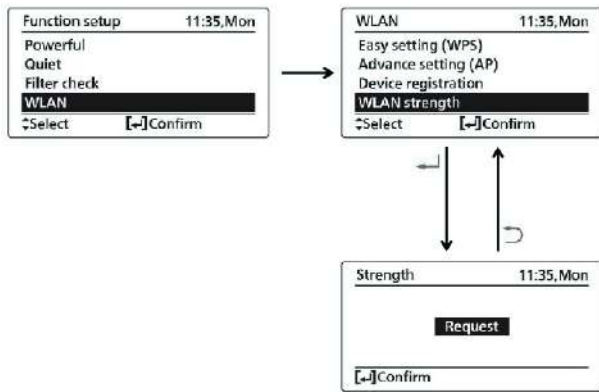

- After 5 seconds, the signal strength is shown on the indoor unit WLAN LED.  
 Strong Signal: Blink 3 times with an interval.  
 Moderate Signal: Blink 2 times with an interval.  
 Weak Signal: Blink once with an interval.  
 No Signal: OFF.
- It will stop automatically after 10 minutes. To stop immediately, press WLAN button.

### 14.11.7 Wireless LAN Failure Diagnosis

#### 14.11.7.1 Between ID Micon and WLAN Module Failure Detect Condition

- When module and ID micon (CN-LAN) communication is following below condition.
  - No response against sending data.
  - Reply error against sending data.
  - Regularly sending from AC unit (Every 1 minutes).
- Either one from above condition occur, detection will start.
- If for certain time there is no communication and retry is implemented 3 times continuously confirm the error by following below table.
- When failure diagnosis H85 occur.

	WLAN LED	Timer LED
When error condition check	Light up	No light
When retry	Light up	No light
After confirm failure	No light	Blinking

- Cancel Condition: From the module the reply data or the regularly sending data (normal data) is recognized by ID micon.

	WLAN LED	Timer LED
When failure canceled	Light up	No light

- Failure communication parameter setting.

H85 communication error: time/retry counter	10 min/3 count
WLAN disconnection judgment time	300 sec

#### **14.11.8 Between ID AC and Broadband Router Failure Detect Condition**

- Detect condition: Communication with router is interrupted.
- Confirm condition: The interrupted condition continue more than 5 minutes and retry is implemented.
- After confirm the failure operation: Not H85 error display and WLAN LED is blinking.
- Cancel condition: Communication is return between WLAN router.
- After cancel, return to normal operation and Wireless LAN LED is light up.

## 14.12 Duty Rotation Control (Optional)

(This control only applies to CS-Z25YKEA/Z35YKEA/Z42YKEA/Z50YKEA/Z71YKEA)

### 1.1 System outline

#### Purpose

Duty rotation allows cascade management (Periodic turn-based turning on and off) of multiple units in an air-conditioned environment so that overall lifespan of unit can be extended and backup units are available in the case of malfunction encountered by running units.

Duty rotation in YKEA model involves two units connected to one wired remote control, classified as Main unit (connected to CN-CNT (A) port) and Sub unit (connected to CN-CNT (B) port). Duty rotation is managed by a built-in software in wired remote controller (instead of indoor unit software). During normal operation, unit is controlled by wired remote controller through CN-RMT transmission. During Duty rotation, wired remote controller will send signals periodically through CN-CNT (A and B) signals to indoor unit to turn ON/OFF the units.

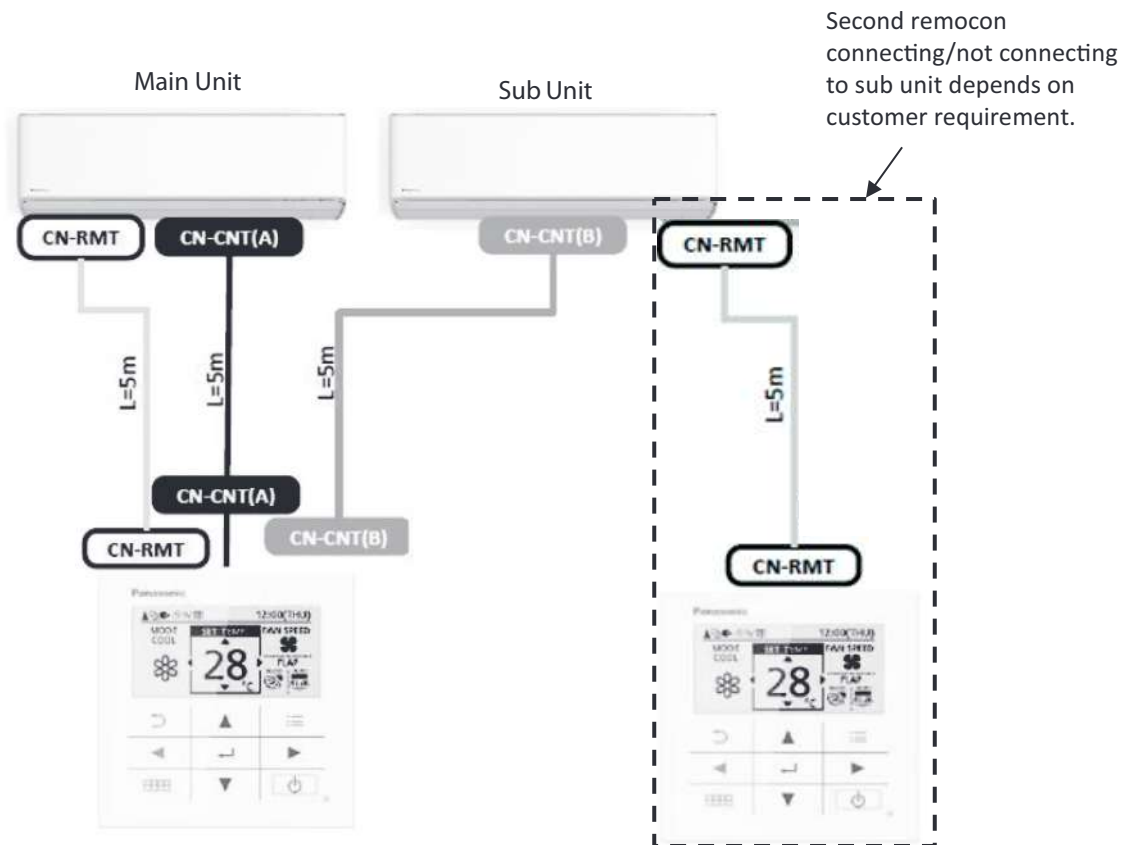

Figure 1.1 Duty rotation system outline showing Main unit, Sub unit, CN-RMT and CN-CNT

## 1.2 Duty Rotation mechanism (Controlled by CN-CNT Signal)

Upon turning Duty Rotation ON from OFF, Main unit will be always be turned on first (becomes running unit). Sub unit will become the backup unit. Running and backup unit will rotate based on a rotation interval set from remote controller. After rotation interval ends, Main unit will be turned off (becomes backup unit) and Sub unit will be turned on (becomes running unit) for the next rotation cycle. Role of running and backup unit will rotate between Main and Sub unit for each new rotation cycle.

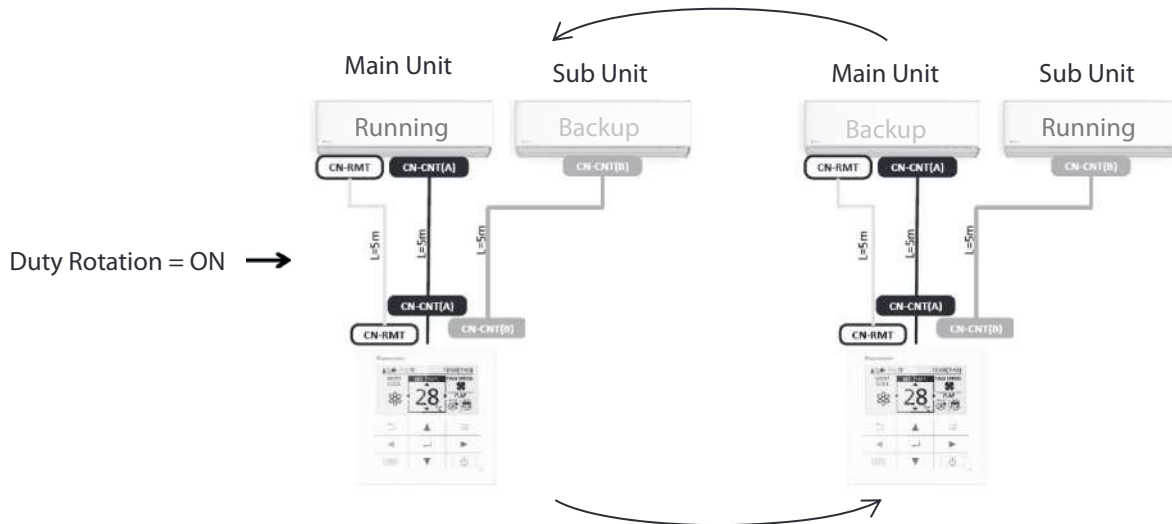

Figure 1.2 Rotation of running/backup unit roles between Main and Sub unit

## 1.3 Unit response to error and breakdown (Controlled by CN-CNT Signal)

When error is encountered during duty rotation, remocon sends signal accordingly to ensure that there is at least one unit running to maintain air-conditioning. This is the general trend of remocon response:

Situation encountered by unit	Unit response	Remocon Signal Response
System error	Turned off due to error detection	Turn on backup unit
Communication error	Resume previous state until communication restored	Turn on backup unit, and check communication with error unit
Power breakdown	Resume previous state after breakdown	None (due to no power)

### A. Unit response when error is encountered during duty rotation

1. When a CNT communication error is detected on the running unit, the running unit will continue its previous state (no signal sent from remocon) but backup unit will be turned on by remocon with rotation counter reset.

2. When a CNT communication error is detected on the backup unit, both running unit and backup unit will continue its previous state (no signal sent from remote) with rotation counter cleared.
3. When a system error (indicated by timer LED blinking) is detected on the running unit and the running unit is turned off by indoor control due to error detection, backup unit will be turned on by remote with rotation counter cleared.
4. When a system error detected on the backup unit and it is turned off by indoor control due to error detection, rotation counter is cleared.

#### B. Unit response when error is cleared during duty rotation

1. When CNT communication error detected on the running unit is cleared, the running unit will continue running and backup unit will be turned off by remote. Rotation counter will restart.
2. When CNT communication error detected on the backup unit is cleared, the running unit will continue running and backup unit will be turned off by remote. Rotation counter will restart.
3. When system error detected on the running unit or backup unit is solved, the running unit or backup unit may not turn ON (Timer LED is still blinking) as the error is still memorised in the indoor unit. It is required to reactivate the duty rotation manually.

#### C. Unit response after recovery from power breakdown

Duty rotation will resume and Main unit will become running unit, Sub unit will become the backup unit. Rotation counter will start anew.

### 10.4 Setting thru WLAN prohibition control (Indoor control)

Purpose:

During duty rotation mode, wired remote control will repetitively send a CN-CNT signal to indoor unit based on a time interval, and indoor unit will send feedback signal to wired remote control for wired remote control to compare and verify signal. It is important to prevent wifi setting change signal from wifi app from clashing with the CN-CNT signal and disrupt duty rotation.

Wired remote control will set Setting change thro' WLAN Flag by CN-CNT signal.

1. When Setting change thro' WLAN Flag = Disable, indoor unit should ignore all setting change (including AI ON/OFF setting) through wifi app.
2. When Setting change thro' WLAN Flag = Enable, indoor unit should accept all setting change (including AI ON/OFF setting) through wifi app.

(Note: WLAN feature/operation is not disabled at any conditions, user is still able to monitor unit through Wi-Fi app)

Diagram below illustrates the control activation during duty rotation:

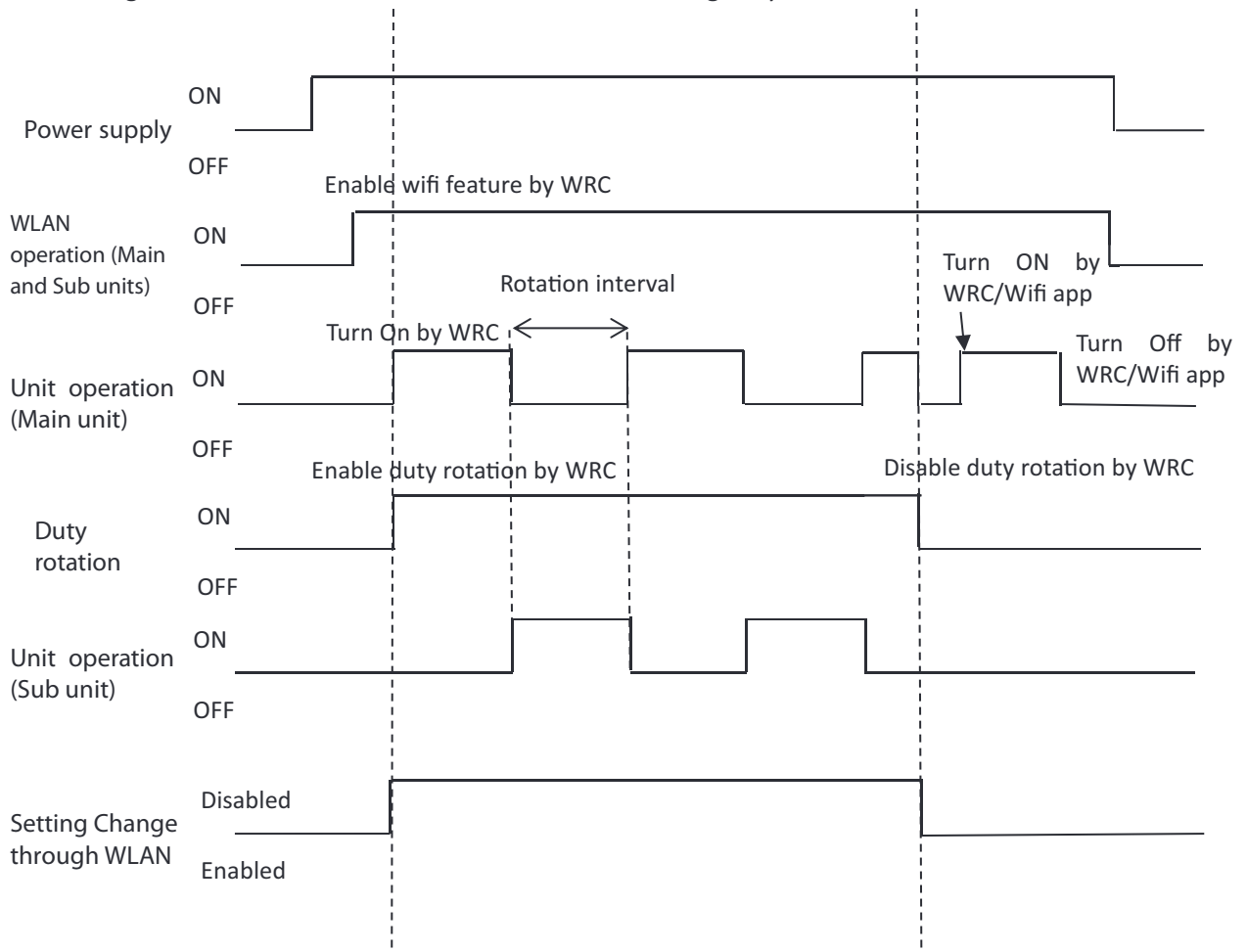

\*Note: WRC = Wired Remote Control

## 1.5 CN-CNT communication error handling Control (Indoor Control)

Starting Conditions:

1. When Duty Rotation flag = ON
2. When indoor unit has not received CN-CNT signal from wired remote control for 3 min (counted by a timer, this timer is reset each time when a CN-CNT signal is received) continuously.

Control content:

When both starting conditions 1 and 2 are fulfilled:

1. Turn off indoor unit.
2. Set Duty Rotation flag = OFF.

When starting condition 2 is fulfilled (regardless of starting condition 1 fulfilled or not):

1. Set Setting change thro' WLAN Flag = Enable (allow wifi app to change setting)

\*\* Note:

1. No cancel conditions because when CN-CNT signal is received again from wired remote control, it will overwrite the previous setting.
2. The timer in this control is same as the timer for wired remote control prohibition).

Indoor functionalities during Duty Rotation

Illustrated below are the unit response on different cases encountered during Duty Rotation as a result combined action from indoor CN-CNT communication error handling control and remote controller CN-CNT protocol.

A) During Duty Rotation = OFF

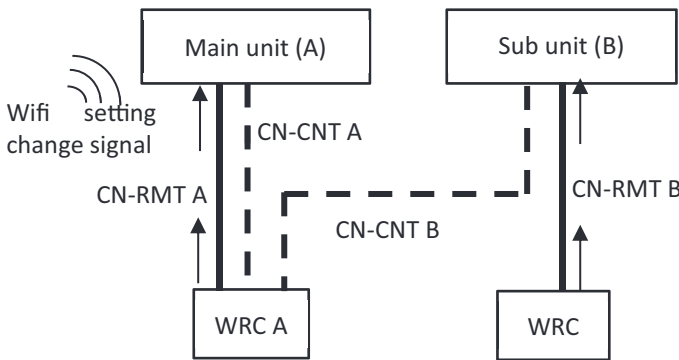

- Wifi setting change signal
1. CN-CNT Signal to A and B: OFF
  2. Setting change through WRC (CN-RMT signal) Flag for A and B: Enabled
  3. Setting change through WLAN Flag for A and B: Enabled
  4. Operation ON/OFF for A and B: By CN-RMT Setting
  5. Rotation interval: Setting value
  6. Duty rotation flag for A and B: OFF

B) During Duty Rotation = ON

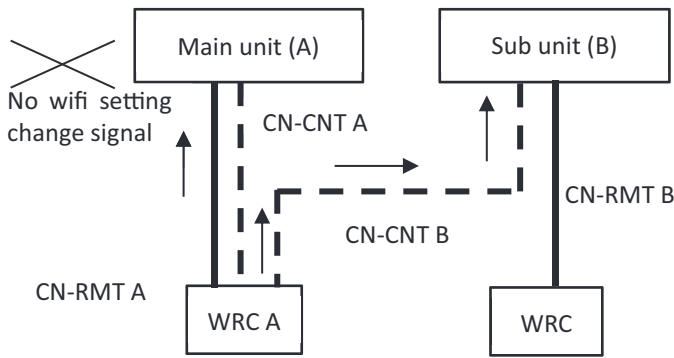

- No wifi setting change signal
1. CN-CNT Signal to A and B: ON
  2. Setting change through WRC (CN-RMT signal) Flag for A and B: Disabled by CN-CNT signal
  3. Setting change through WLAN Flag for A and B: Disabled by CN-CNT signal
  4. Operation ON/OFF for A and B: By rotation interval
  5. Rotation interval: Setting value
  6. Duty rotation flag for A and B: ON

C) During Duty Rotation = ON, CN-CNT A is malfunctioned

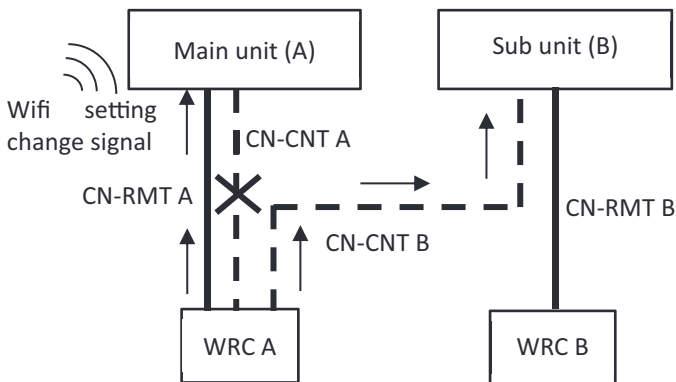

- No wifi setting change signal
1. CN-CNT Signal to A: OFF (Malfunctioned), B: ON
  2. Setting change through WRC (CN-RMT signal) Flag for A: Enabled after 3min no CN-CNT A signal, B: Disabled
  3. Setting change through WLAN Flag for A: Enabled after 3min no CN-CNT A signal, B: Disabled
  4. Operation ON/OFF for A: OFF after 3mins no CN-CNT A signal until recovery B: ON by CN-CNT B signal after 1min no CN-CNT A signal
  5. Rotation interval: After 1min no CN-CNT A signal, set to zero until recovery
  6. Duty rotation flag for A: OFF after 3min no CN-CNT A signal until recovery, B: ON

D) During Duty Rotation = ON, CN-CNT B is malfunctioned

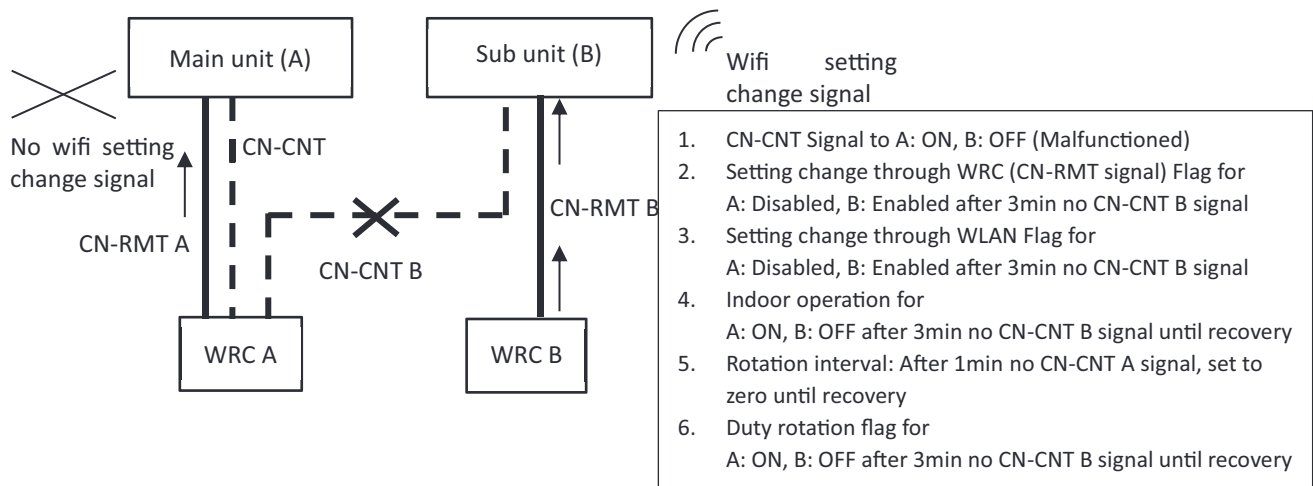

E) During Duty Rotation = ON, both CN-CNT A and B are malfunctioned

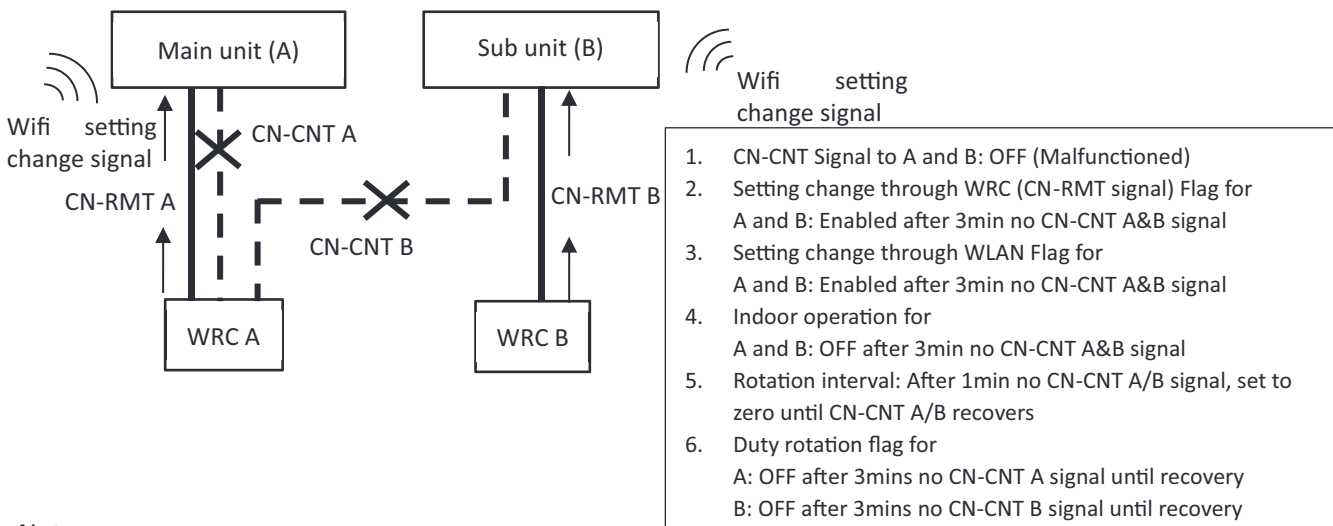

Note:

- 1) WRC = Wired Remote Control
- 2) The above cases assume that users do not change Duty Rotation setting at any time.
- 3) After both CN-CNTs are recovered from Case C, D, E, return to Case B.
- 4) If only CN-CNT A or CN-CNT B is recovered from Case E, return to Case D or Case C respectively.
- 5) For running unit B in Case C and unit A in Case D, running operation will follow setting set when duty rotation is started. To change setting through WRC (CN-RMT signal) or Wi-Fi, users need to turn off Duty rotation mode first in WRC. After turned off, Duty rotation mode cannot be turned on again if the malfunctioned CN-CNT is not repaired.
- 6) If WRC B is not connected to Sub unit (B), setting change through WRC (CN-RMT signal) is not possible for unit B.

## 14.13 Duty Rotation Setup

### 14.13.1 Setting Up Duty Rotation

1. Before setting up duty rotation, ensure that:
  - a. Both CNT cables are connected to the main indoor unit and sub indoor unit.
  - b. Setting in **Operation screen** (Mode, set temperature, Fan speed, flap position) is set to desired setting before turning ON duty rotation.

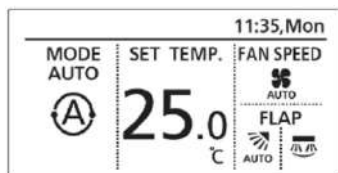

- c. Both main and sub units are turned off.

2. Using Wired Remote Controller, at **Main Menu**, go to **Function Setup** → **Duty rotation**.

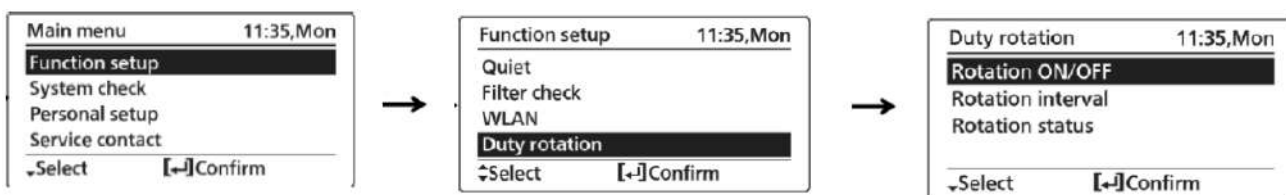

3. Select **Rotation interval** and set preferred interval. (Refer to 14.13.4 Changing Duty Rotation Interval for more details)
4. Return to **Duty rotation**, go to **Rotation ON/OFF**. Select **ON** and confirm.

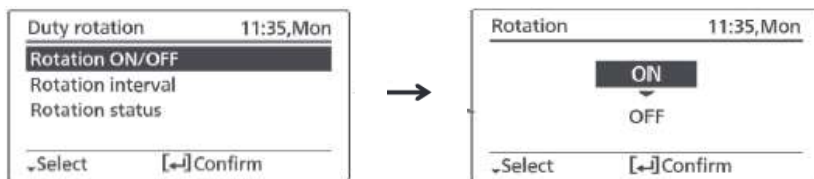

Note: Attempt to turn ON Duty rotation when operation ON will display a pop-up window:

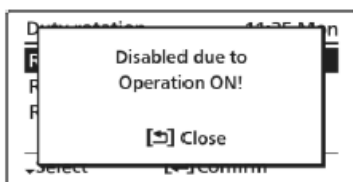

5. Wired remote controller will attempt to establish connection with the two units:

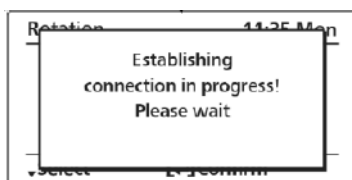

If connection is successful, the following pop-up window will appear:

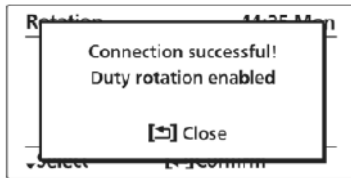

If connection is unsuccessful, either one of the three pop-up window will appear:



1. *Connection with both units failed*

2. *Connection with main unit failed only*

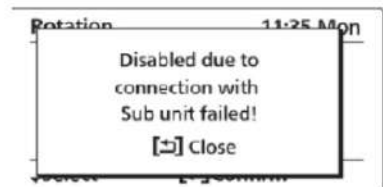
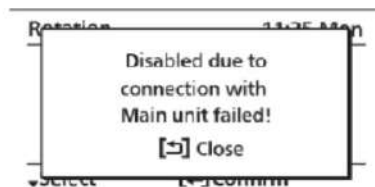
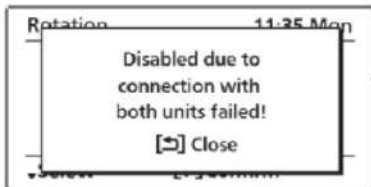
3. *Connection with sub unit failed only*



Please ensure that both CNT cables are connected properly at indoor unit and wired remote controller according to CNT cable Installation Manual. After that, repeat Steps 1. to 5. (Contact an authorised dealer if problem persists).

6. After connection is successful, press  to close the pop-up window. After returning to **Operation Screen**, Duty Rotation icon  should appear on the Top left corner. This icon will appear throughout Duty Rotation operation.

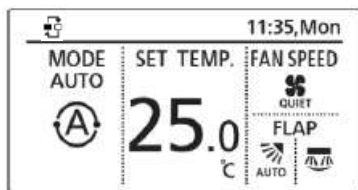

The operation setting for Duty rotation mode will follow the previous setting saved before operation OFF.

### 14.13.2 Setting change during Duty Rotation

Setting change is prohibited during Duty Rotation. Attempting to change setting or pressing  will result in the following pop-up window:

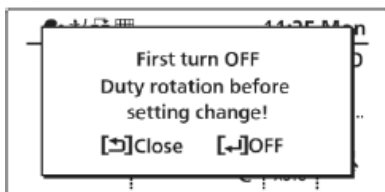

Press  to close the pop-up window.

### 14.13.3 Cancelling Duty Rotation

Cancelling Duty Rotation will end duty rotation operation and turn off main and sub units. To cancel duty rotation, there are two methods:

#### A. Through Rotation ON/OFF Screen

Go to **Main Menu** → **Function Setup** → **Duty rotation** → **Rotation ON/OFF**. Select **OFF** and confirm to cancel Duty Rotation and turn off units.

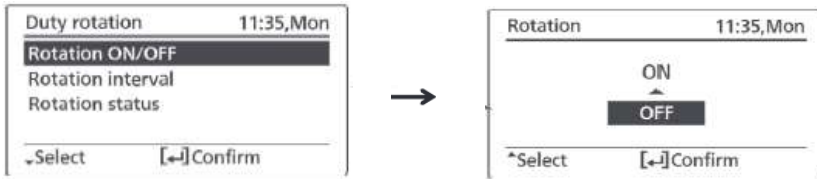

#### B. Through Operation Screen

- Go to **Operation Screen** and press , , , or to show a pop-up window. Confirm "OFF" will prompt a second pop-up window confirming turning OFF duty rotation.

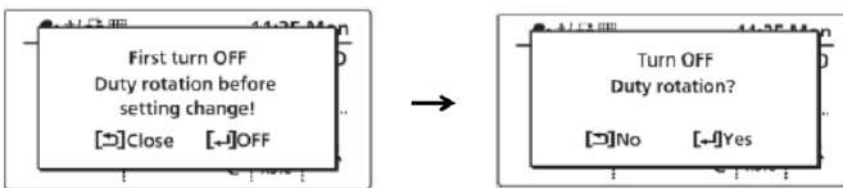

- Confirm "Yes" to cancel Duty Rotation and turn off units.

### 14.13.4 Changing Duty Rotation Interval

Duty rotation interval can be changed at any time when Duty rotation is ON or OFF:

- Go to **Main Menu** → **Function Setup** → **Duty rotation** → **Rotation interval**

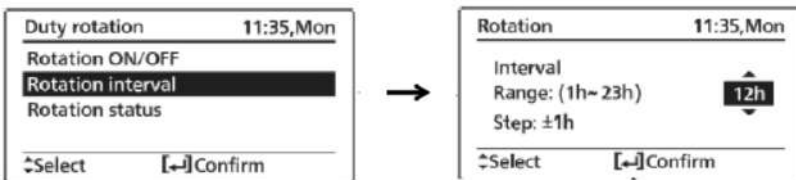

Default interval is 12 hours.

- \*Select Interval between 1 hour (minimum) to 23 hours (maximum) and confirm.

\*Note: If Duty rotation interval is changed when Duty rotation is ON, the rotation counter will reset to the newly confirmed interval.

### 14.13.5 Monitoring Duty Rotation

Using a status screen, duty rotation operation can be monitored to detect errors and check rotation interval.

- Go to **Main Menu** → **Function Setup** → **Duty rotation** → **Rotation status**
- Rotation status** screen (during Duty Rotation = OFF). There are two pages:



- Monitoring details A, B, C are described below:

1. Main/Sub unit communication status:

Status	Display
Remote controller is able to communicate with Main unit	Main unit comm. : ✓
Remote controller is unable to communicate with Main unit	Main unit comm. : ✕
Remote controller is able to communicate with Sub unit	Sub unit comm. : ✓
Remote controller is unable to communicate with Sub unit	Sub unit comm. : ✕

2. Main/Sub unit operation status:

Status	Display
Main unit is ON	Main unit: ON
Main unit is OFF	Main unit: OFF
Main unit encounters a system error (for example, H23 error: Indoor heat exchanger temperature sensor 1 abnormality)	Main unit: H23
Sub unit is ON	Sub unit: ON
Sub unit is OFF	Sub unit: OFF
Sub unit encounters a system error (for example, H23 error: Indoor heat exchanger temperature sensor 1 abnormality)	Sub unit: H23

3. Time left before rotation:

Status	Display
When one of the below happens: A) Duty Rotation is OFF B) Duty Rotation is ON but remote controller is unable to communicate with Main/Sub unit C) Duty Rotation is ON but Main/Sub unit encounters a system error	Time left :  (Counter is reset)
Other than the above (For example, time left before rotation is 11:59:59)	Time left : 11:59:59

Note: If “Time left” reaches “00:00:00”, the running unit will be turned off (becomes the backup unit) and the backup unit will be turned on (becomes the running unit). “Time left” renews according to set rotation interval and counting restarts for the next rotation cycle.

4. Examples of **Rotation Status** screen:

a. **Rotation Status** screen during Duty Rotation = ON without error:

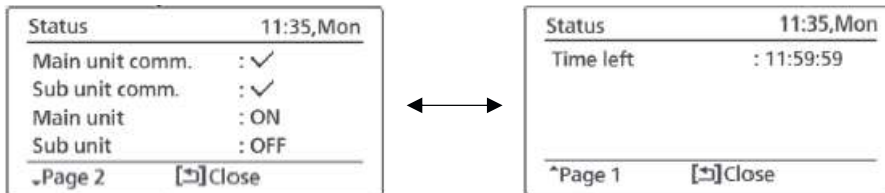

b. **Rotation Status** screen during Duty Rotation = ON with communication error only:

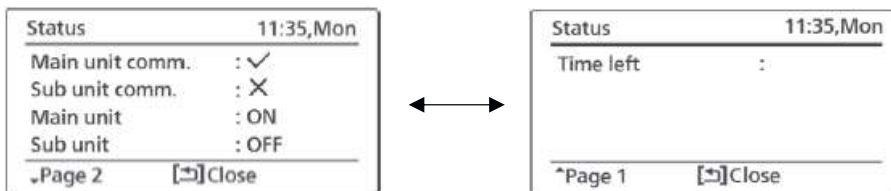

c. **Rotation Status** screen during Duty Rotation = ON with system error only:

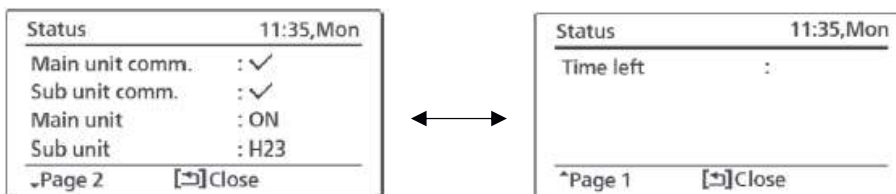

4. **Rotation Status** screen will update according to the latest status.

### 14.13.6 Remote controller screen behaviour when encountering error

1. When CNT communication error or system error is detected on either main or sub unit, remote controller screen will automatically enter **Rotation status** screen and screen backlight will blink.

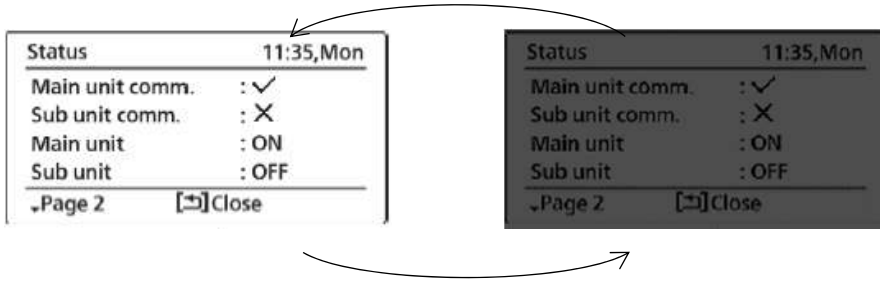

2. The remote controller screen blinking stops when error is cleared during Duty Rotation ON or Duty Rotation is cancelled.
3. If the **Rotation Status** screen is not manually exited, the screen will return to **Operation screen** and remote controller screen blinking stops after error is solved.

### 14.13.7 System behaviour during duty rotation

#### A. Duty rotation mechanism

1. Upon turning Duty Rotation ON from OFF, Main unit will be turned on (becomes running unit). Sub unit will become the backup unit.

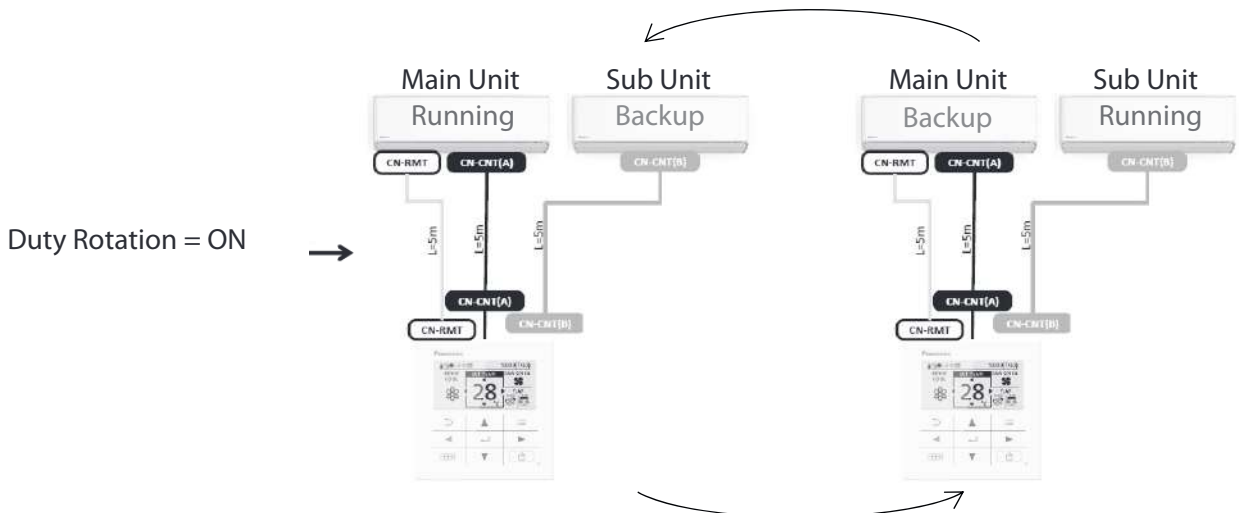

2. After rotation interval ends, Main unit will be turned off (becomes backup unit) and Sub unit will be turned on (becomes running unit) for the next rotation cycle. Role of running and backup unit will rotate between Main and Sub unit for each new rotation cycle.

#### B. Unit response when error is encountered during duty rotation

1. When a CNT communication error is detected on the running unit, the running unit will continue its previous state but backup unit will be turned on with rotation counter cleared (blank).
2. When a CNT communication error is detected on the backup unit, both running unit and backup unit will continue its previous state with rotation counter cleared.
3. When a system error (indicated by timer LED blinking) is detected on the running unit and the running unit is turned off, backup unit will be turned on with rotation counter cleared.
4. When a system error detected on the backup unit and backup unit is turned off, rotation counter is cleared.

#### C. Unit response when error is cleared during duty rotation

1. When CNT communication error detected on the running unit is cleared, the running unit will continue running and the backup unit will be turned off. Rotation counter will start anew.
2. When CNT communication error detected on the backup unit is cleared, the running unit will continue running and the backup unit will be turned off. Rotation counter will start anew.
3. When system error detected on the running unit or backup unit is solved, the running unit or backup unit may not turn ON (Timer LED is still blinking) as the error is still memorised in the indoor unit. To solve this:

1. Turn off duty rotation (Refer to Section 4. Cancelling Duty Rotation, Pg 5 for steps)
2. Go to **Quick Menu**, and select  AC Reset and confirm to clear Timer LED blinking.

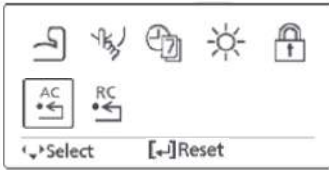

3. Turn on duty rotation again (Refer to Section 2. Setting up Duty Rotation, Pg 4 for steps)

**D. Unit response after recovery from power breakdown**

After recovery from power breakdown:

1. Duty rotation will resume and Main unit will become the running unit, sub unit will become the backup unit.
2. Rotation counter will start anew.

**E. Unit treatment of setting change signals sent during duty rotation**

1. During Duty Rotation, both Main unit and Sub unit ignore setting change instructions sent from remote controller and Comfort Cloud app.
2. If CNT communication error on a unit is detected for more than 2 minutes, that unit is allowed to accept setting change instruction from remote controller and Comfort Cloud app. After communication error is cleared, that unit will start to ignore setting change instructions.

**F. Support of Backup unit during high set temperature vs room temperature difference**

Room temperature is detected by the running unit. Upon reaching a set temperature vs room temperature difference threshold, backup unit will be turned on or off to support running unit:

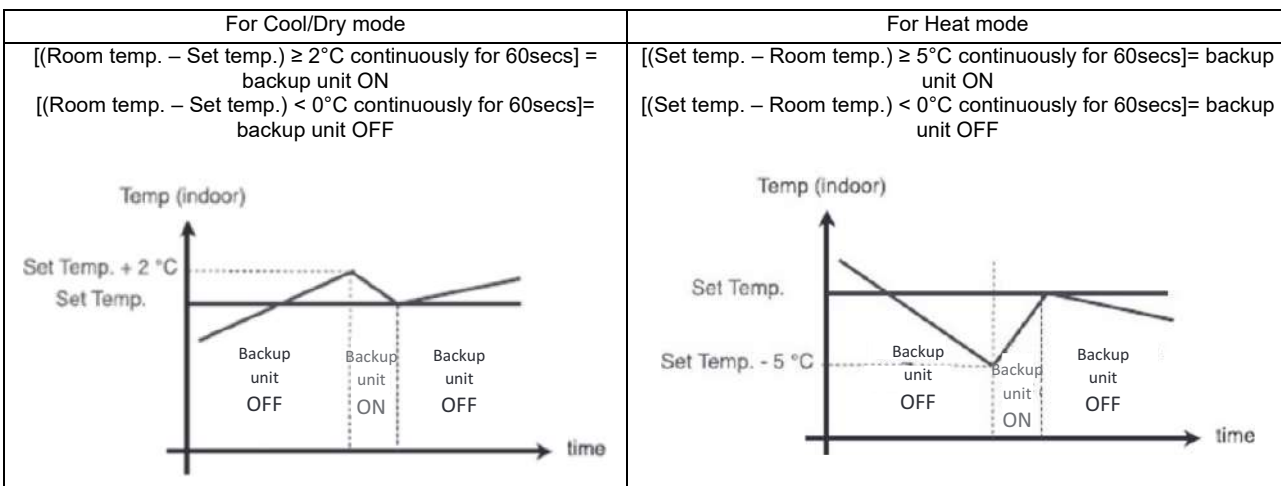

**14.13.8 System check during duty rotation**

System check can be performed during duty rotation:



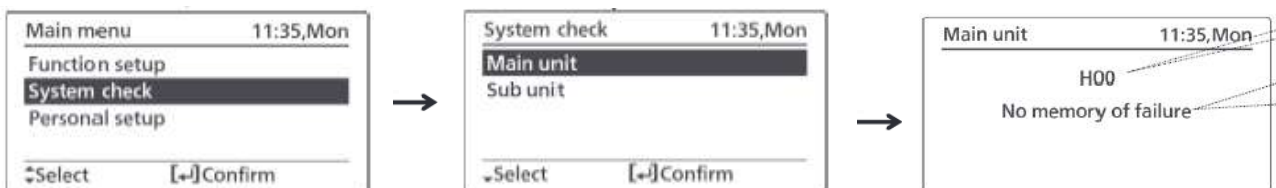





1. Go to **Main Menu** → **System check**.
2. Select **Main unit** to check system error for Main unit.

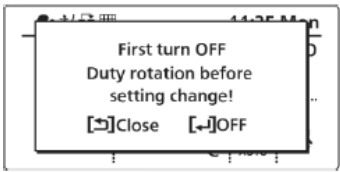
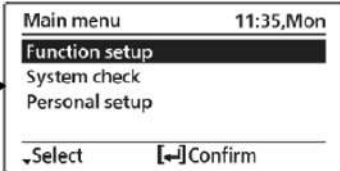
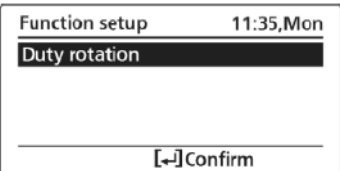
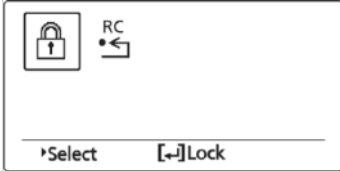

3. Select **Sub unit** to check system error for Sub unit.

### 14.13.9 Features restriction during duty rotation

Several features are restricted during duty rotation to prevent unwanted interruption:

Feature	Display	Feature restriction during duty rotation
1. <b>Operation screen</b>		All settings are prohibited to change unless Duty rotation is cancelled first (this will turn off units): <ul style="list-style-type: none"> <li>• Mode</li> <li>• Set temperature</li> <li>• Fan speed</li> <li>• Horizontal flap position</li> <li>• Vertical flap position</li> </ul>
2. <b>Main menu</b>		Only the following items are available on Duty Rotation: <ul style="list-style-type: none"> <li>• <b>Function setup</b></li> <li>• <b>System check</b></li> <li>• <b>Personal setup</b></li> </ul> The following items are unavailable on Duty Rotation: <ul style="list-style-type: none"> <li>• <b>Service contact</b></li> <li>• <b>Custom setup</b></li> </ul>
3. <b>Function setup</b>		Only the following items are available on Duty Rotation: <ul style="list-style-type: none"> <li>• <b>Duty rotation</b></li> </ul> The following items are unavailable on Duty Rotation: <ul style="list-style-type: none"> <li>• <b>Model type</b></li> <li>• <b>Heat mode</b></li> <li>• <b>Left/Right swing</b></li> <li>• <b>Powerful</b></li> <li>• <b>Quiet</b></li> <li>• <b>Filter reset</b></li> <li>• <b>WLAN</b></li> <li>• <b>Diagnosis</b></li> </ul>
4. <b>Quick menu</b>		Only the following items are available on Duty Rotation: <ul style="list-style-type: none"> <li>•  RC lock</li> <li>•  RC Reset</li> </ul> The following items are unavailable on Duty Rotation: <ul style="list-style-type: none"> <li>•  Powerful</li> <li>•  Quiet</li> <li>•  Weekly timer</li> <li>•  Filter reset</li> <li>•  LED Intensity Dim</li> <li>•  AC Reset</li> </ul>
5. <b>Weekly timer</b>	-	Weekly timer is disabled during Duty Rotation, but will resume after Duty Rotation is turned off.

## 15. Protection Control

### 15.1 Protection Control for All Operations

#### 15.1.1 Restart Control (Time Delay Safety Control)

- The Compressor will not turn on within 3 minutes from the moment operation stops, although the unit is turned on again by pressing OFF/ON button at remote control within this period.
- This control is not applicable if the power supply is cut off and on again.
- This phenomenon is to balance the pressure inside the refrigerant cycle.

#### 15.1.2 Total Running Current

- 1 When the outdoor unit total running current (AC) exceeds X value, the frequency instructed for compressor operation will be decreased.
- 2 If the running current does not exceed X value for 5 seconds, the frequency instructed will be increased.
- 3 However, if total outdoor unit running current exceeds Y value, compressor will be stopped immediately for 3 minutes.

Model	Z25YKEA		Z35YKEA		Z42YKEA		Z50YKEA		Z71YKEA	
	X (A)	Y (A)	X (A)	Y (A)	X (A)	Y (A)	X (A)	Y (A)	X (A)	Y (A)
Cooling / Soft Dry (A)	4.80	14.66	6.34	14.66	7.51	14.66	9.87	14.66	13.67	19.01
Cooling / Soft Dry (B)	4.25		5.88		6.88		9.41		11.77	
Cooling / Soft Dry (C)	4.25		5.88		6.88		9.41		11.77	
Heating	5.07		6.06		7.15		9.14		12.22	

- 4 The first 30 minutes of cooling operation, (A) will be applied.

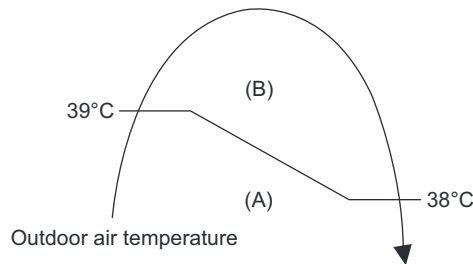

#### 15.1.3 IPM (Power transistor) Prevention Control

- Overheating Prevention Control
  - 1 When the IPM temperature rises to 120°C, compressor operation will stop immediately.
  - 2 Compressor operation restarts after 3 minutes the temperature decreases to 110°C.
  - 3 If this condition repeats continuously 4 times within 20 minutes, timer LED will be blinking ("F96" is indicated).
- DC Peak Current Control
  - 1 When electric current to IPM exceeds set value of 16.0 ± 2.0A (Z25/35/42YK) and 30.0 ± 3.0A (Z50/71YK), the compressor will stop operate. Then, operation will restart after 3 minutes.
  - 2 If the set value is exceeded again more than 30 seconds after the compressor starts, the operation will restart after 1 minute.
  - 3 If the set value exceeded again within 30 seconds after the compressor starts, the operation will restart after 1 minute. If this condition repeats continuously for 7 times, all indoor and outdoor relays will be cut off, timer LED will be blinking ("F99" is indicated).

#### 15.1.4 Compressor Overheating Prevention Control

- Instructed frequency for compressor operation will be regulated by compressor temperature. The changes of frequency are as below.
- If compressor temperature exceeds 103°C, compressor will be stopped, occurs 4 times per 20 minutes, timer LED will be blinking. ("F97" is indicated.)

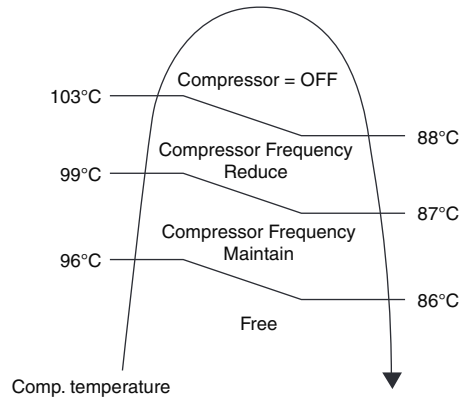

### 15.1.5 Low Pressure Prevention Control (Gas Leakage Detection)

- Control start conditions
  - For 5 minutes, the compressor continuously operates and outdoor total current is between 0.36A and 0.54A (Z35/42/50/71YKEA), between 0.29A and 0.44A (Z25YKEA).
  - During Cooling and Soft Dry operations:  
Indoor suction temperature - indoor piping temperature is below 4°C.
  - During Heating operations :  
Indoor piping temperature - indoor suction is under 5°C.
- Control contents
  - Compressor stops (and restart after 3 minutes).
  - If the conditions above happen 2 times within 20 minutes, the unit will:
    - Stop operation
    - Timer LED blinks and “F91” indicated.

### 15.1.6 Low Frequency Protection Control 1

- When the compressor operate at frequency lower than 24 Hz continued for 240 minutes, the operation frequency will be changed to 23 Hz for 2 minutes.

### 15.1.7 Low Frequency Protection Control 2

- When all the below conditions comply, the compressor frequency will change to lower frequency.

Temperature, T, for:	Cooling/Soft Dry	Heating
Indoor intake air (°C)	T < 14 or T ≥ 30	T < 14 or T ≥ 28
Outdoor air (°C)	T < 13 or T ≥ 38	T < 4 or T ≥ 24
Indoor heat exchanger (°C)	T < 30	T ≥ 0

## 15.2 Protection Control for Cooling & Soft Dry Operation

### 15.2.1 Outdoor Air Temperature Control

- The compressor operating frequency is regulated in accordance to the outdoor air temperature as shown in the diagram below.
- This control will begin 1 minute after the compressor starts.
- Compressor frequency will adjust base on outdoor air temperature.

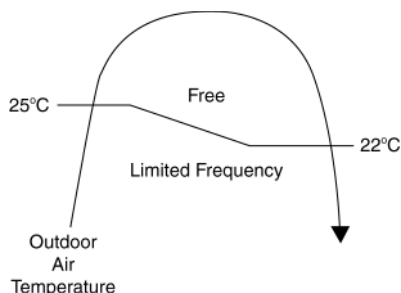

- The compressor will be stopped to avoid compressor overloading.

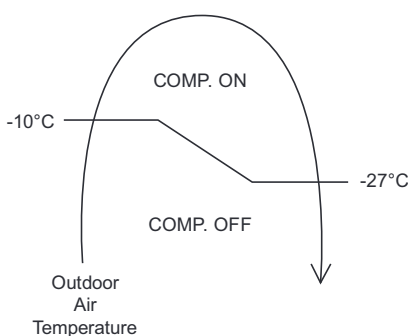

### 15.2.2 Cooling Overload Control

- Detects the Outdoor pipe temperature and carry out below restriction/limitation (Limit the compressor Operation frequency).
- The compressor stop if outdoor pipe temperature exceeds 60°C.
- If the compressor stops 4 times in 20 minutes, Timer LED blinking (F95 indicated: outdoor high pressure rise protection).

### 15.2.3 Freeze Prevention Control 1

- When indoor heat exchanger temperature is lower than 0°C continuously for 6 minutes, compressor will stop operating.
- Compressor will resume its operation 3 minutes after the indoor heat exchanger is higher than 5°C.
- At the same time, indoor fan speed will be higher than during its normal operation.
- If indoor heat exchanger temperature is higher than 13°C, the fan speed will return to its normal operation.

### 15.2.4 Freeze Prevention Control 2

- Control start conditions
  - During Cooling operation and soft dry operation
    - During thermo OFF condition, indoor intake temperature is less than 10°C or
    - Compressor stops for freeze prevention control
  - Either one of the conditions above occurs 5 times in 60 minutes.
- Control contents
  - Operation stops
  - Timer LED blinks and "H99" indicated

### 15.2.5 Dew Prevention Control 1

- To prevent dew formation at indoor unit discharge area.
- This control will be activated if:
  - Outdoor air temperature and Indoor pipe temperature judgment by microcontroller is fulfilled.
  - When Cooling or Dry mode is operated more than 20 minutes or more.
- This control stopped if:
  - Compressor stopped.
  - Remote control setting changed (fan speed / temperature).
  - Outdoor air temperature and indoor intake temperature changed.
- Fan speed will be adjusted accordingly in this control.

### 15.2.6 Odor Cut Control

- To reduce the odor released from the unit.
  - Start Condition
    - AUTO FAN Speed is selected during COOL or DRY operation.
    - During freeze prevention control and timer preliminary operation, this control is not applicable.
  - Control content
    - Depends on compressor conditions:
      1. Compressor OFF → Compressor ON.  
The indoor unit fan stops temporarily and then starts to blow at minimum airflow for 30 seconds.
      2. Compressor ON → Compressor OFF.  
The indoor unit fan stops for 90 seconds and then blows at minimum airflow for 20 seconds.

## 15.3 Protection Control for Heating Operation

### 15.3.1 Intake Air Temperature Control

Compressor will operate at limited freq., if indoor intake air temperature is 30°C or above.

### 15.3.2 Outdoor Air Temperature Control

- The Max current value is regulated when the outdoor air temperature rise above 14°C in order to avoid compressor overloading.

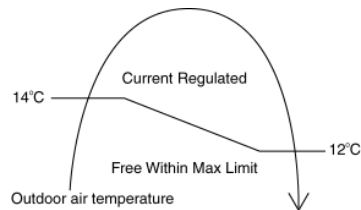

### 15.3.3 Overload Protection Control

- The compressor operating frequency is regulated in accordance to indoor heat exchanger temperature as shown below.
- If the heat exchanger temperature exceeds 60°C, compressor will stop.

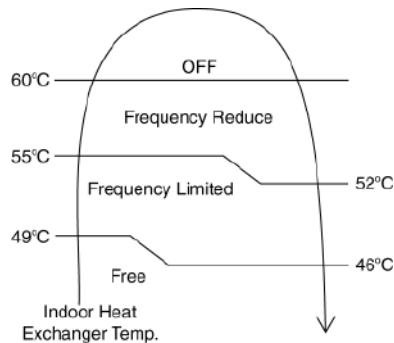

#### **15.3.4 Low Temperature Compressor Oil Return Control**

- In heating operation, if the outdoor temperature falls below  $-10^{\circ}\text{C}$  when compressor starts, the compressor frequency will be regulated up to 600 seconds.

#### **15.3.5 Cold Draught Prevention Control**

- When indoor pipe temperature is low, cold draught operation starts where indoor fan speed will be reduced.

#### **15.3.6 Deice Operation**

- When outdoor pipe temperature and outdoor air temperature is low, deice operation start where indoor fan motor and outdoor fan motor stop and operation LED blinks.

#### **15.3.7 Low Pressure Protection Control**

- During low ambient heating operation, if the pipe temperature drops below  $-22^{\circ}\text{C}$ , the max frequency will be reduced and limited.
- If it does not rises after 3 minutes, the compressor will stop.
- The compressor will start again if the pipe temperature rises above  $-18^{\circ}\text{C}$ .

# 16. Servicing Mode

## 16.1 Auto OFF/ON Button

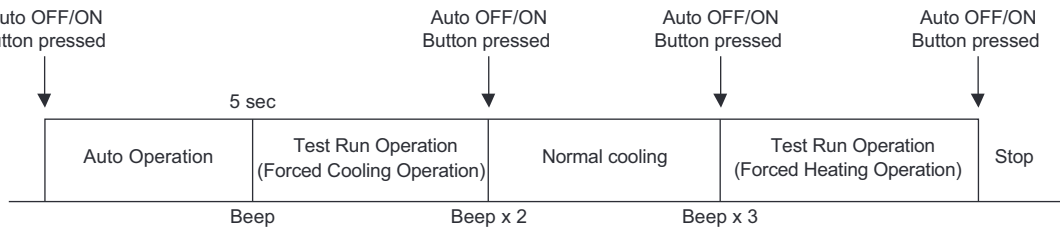

### 1 AUTO OPERATION MODE

The Auto operation will be activated immediately once the Auto OFF/ON button is pressed. This operation can be used to operate air conditioner with limited function if remote control is misplaced or malfunction.

### 2 TEST RUN OPERATION (FOR PUMP DOWN/SERVICING PURPOSE)

The Test Run operation will be activated if the Auto OFF/ON button is pressed continuously for more than 5 seconds. A “beep” sound will heard at the fifth seconds, in order to identify the starting of Test Run operation (Forced cooling operation). Within 5 minutes after Forced cooling operation start, the Auto OFF/ON button is pressed for more than 5 seconds. A 2 “beep” sounds will heard at the fifth seconds, in order to identify the starting of normal cooling. The Auto OFF/ON button is pressed for more than 5 seconds, a 3 “beep” sound will be heard in order to identify the starting of Forced heating operation.

The Auto OFF/ON button may be used together with remote control to set / change the advance setting of air conditioner operation.

# 17. Troubleshooting Guide

## 17.1 Refrigeration Cycle System

In order to diagnose malfunctions, make sure that there are no electrical problems before inspecting the refrigeration cycle. Such problems include insufficient insulation, problem with the power source, malfunction of a compressor and a fan. The normal outlet air temperature and pressure of the refrigeration cycle depends on various conditions, the standard values for them are shown in the table on the right.

Normal Pressure and Outlet Air Temperature (Standard)

	Gas Pressure MPa (kg/cm <sup>2</sup> G)	Outlet air Temperature (°C)
Cooling Mode	0.9 ~ 1.2 (9 ~ 12)	13 ~ 17
Heating Mode	2.0 ~ 2.7 (20 ~ 27)	32 ~ 42

- \*Condition:
- Indoor fan speed = High
  - Outdoor temperature 35°C at the cooling mode and 7°C at the heating mode
  - Compressor operates at rated frequency

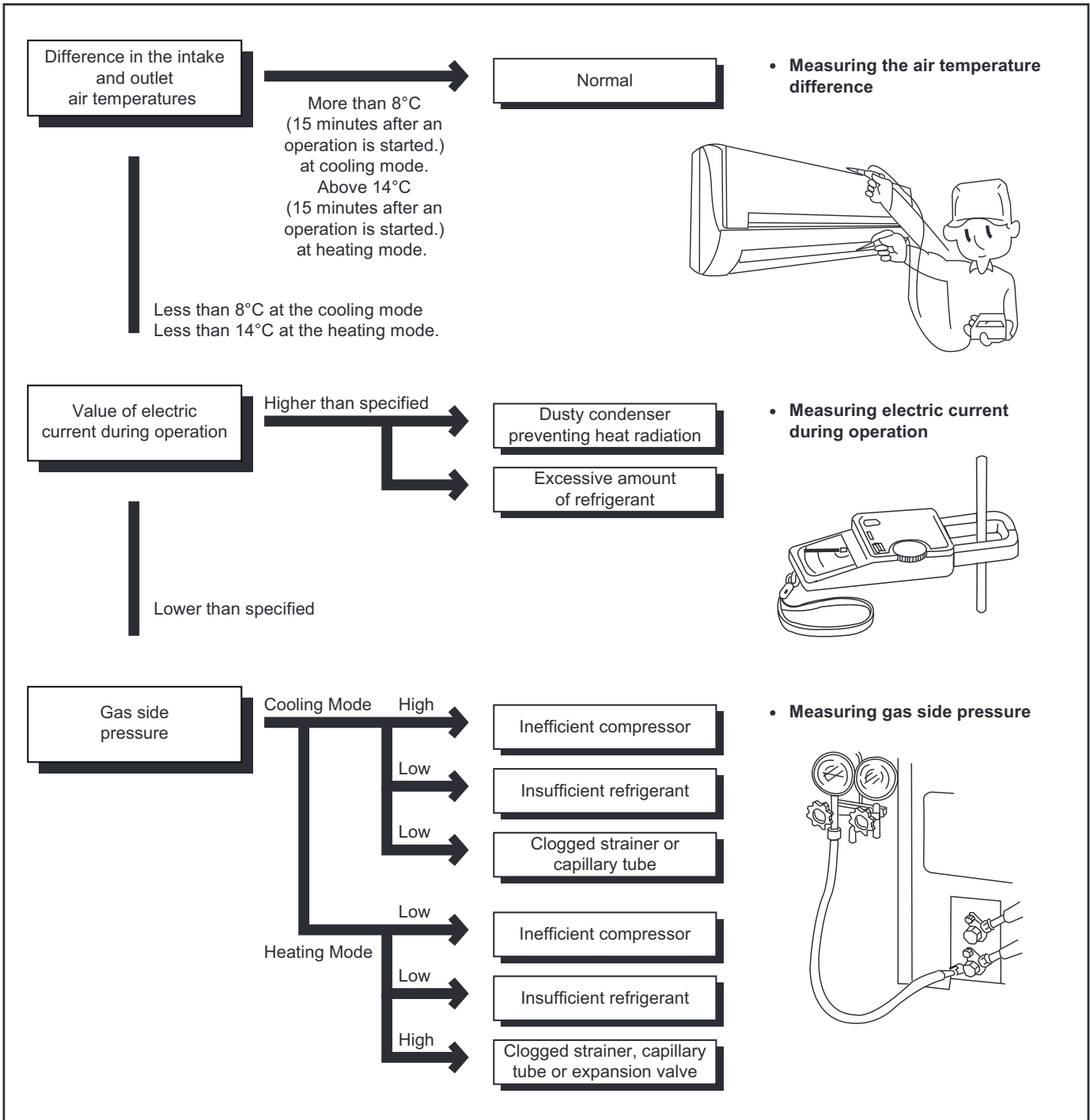

### 17.1.1 Relationship Between the Condition of the Air Conditioner and Pressure and Electric Current

Condition of the air conditioner	Cooling Mode			Heating Mode		
	Low Pressure	High Pressure	Electric current during operation	Low Pressure	High Pressure	Electric current during operation
Insufficient refrigerant (gas leakage)	↘	↘	↘	↘	↘	↘
Clogged capillary tube or Strainer	↘	↘	↘	↗	↗	↗
Short circuit in the indoor unit	↘	↘	↘	↗	↗	↗
Heat radiation deficiency of the outdoor unit	↗	↗	↗	↘	↘	↘
Inefficient compression	↗	↘	↘	↗	↘	↘

- Carry out the measurement of pressure, electric current, and temperature fifteen minutes after an operation is started.

## 17.2 Breakdown Self Diagnosis Function

### 17.2.1 Self Diagnosis Function (Three Digits Alphanumeric Code)

- Once abnormality has occurred during operation, the unit will stop its operation, and Timer LED blinks.
- Although Timer LED goes off when power supply is turned off, if the unit is operated under a breakdown condition, the LED will light up again.
- In operation after breakdown repair, the Timer LED will no more blink.

### 17.2.2 To Make a Diagnosis

- 1 Timer LED start to blink and the unit automatically stops the operation.
- 2 Select System check from remote controller Main menu.

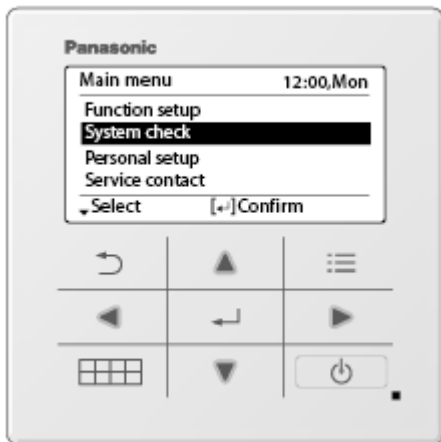

#### Entering method

Case 1: During Operation ON

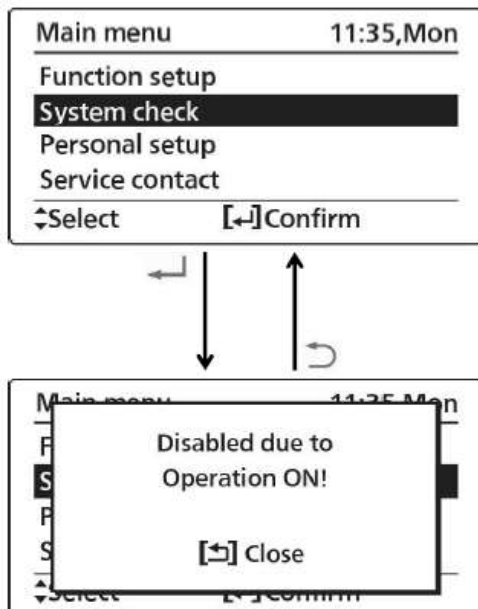

Case 2: During operation OFF in Duty rotation OFF condition

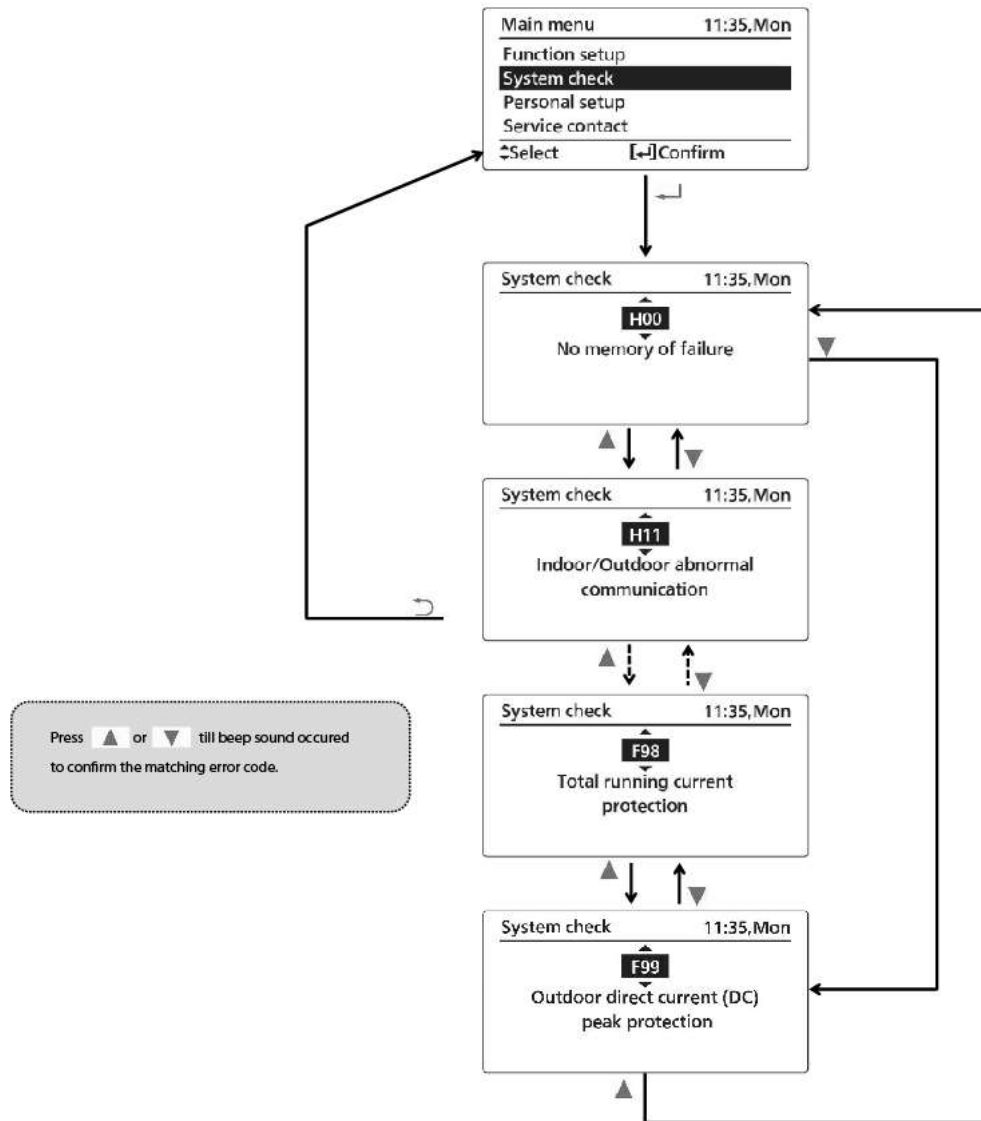

Case 3: During operation OFF in Duty Rotation ON condition

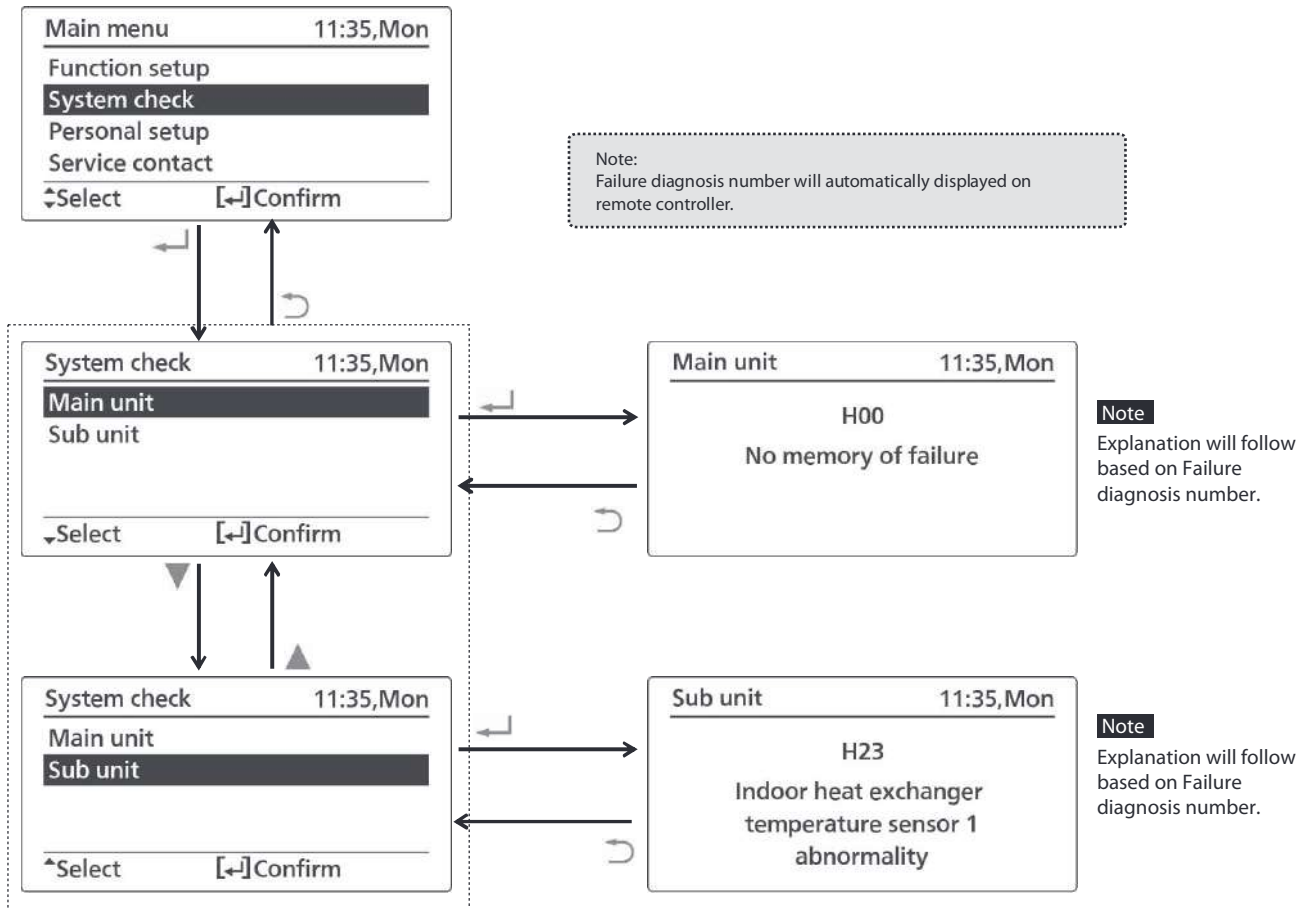

## 17.3 Error Codes Table

Diagnosis display	Abnormality / Protection control	Abnormality Judgment	Protection Operation	Problem	Check location
H00	No memory of failure	—	Normal operation	—	—
H11	Indoor/outdoor abnormal communication	After operation for 1 minute	Indoor fan only operation can start by entering into force cooling operation	Indoor/outdoor communication not establish	<ul style="list-style-type: none"> <li>Indoor/outdoor wire terminal</li> <li>Indoor/outdoor PCB</li> <li>Indoor/outdoor connection wire</li> </ul>
H12	Indoor unit capacity unmatched	90s after power supply	—	Total indoor capability more than maximum limit or less than minimum limit, or number of indoor unit less than two	<ul style="list-style-type: none"> <li>Indoor/outdoor connection wire</li> <li>Indoor/outdoor PCB</li> <li>Specification and combination table in catalogue</li> </ul>
H14	Indoor intake air temperature sensor abnormality	Continuous for 5s	—	Indoor intake air temperature sensor open or short circuit	<ul style="list-style-type: none"> <li>Indoor intake air temperature sensor lead wire and connector</li> </ul>
H15	Compressor temperature sensor abnormality	Continuous for 5s	—	Compressor temperature sensor open or short circuit	<ul style="list-style-type: none"> <li>Compressor temperature sensor lead wire and connector</li> </ul>
H16	Outdoor current transformer (CT) abnormality	—	—	Current transformer faulty or compressor faulty	<ul style="list-style-type: none"> <li>Outdoor PCB faulty or compressor faulty</li> </ul>
H19	Indoor fan motor mechanism lock	Continuous happen for 7 times	—	Indoor fan motor lock or feedback abnormal	<ul style="list-style-type: none"> <li>Fan motor lead wire and connector</li> <li>Fan motor lock or block</li> </ul>
H23	Indoor heat exchanger temperature sensor abnormality	Continuous for 5s	—	Indoor heat exchanger temperature sensor open or short circuit	<ul style="list-style-type: none"> <li>Indoor heat exchanger temperature sensor lead wire and connector</li> </ul>
H24	Indoor heat exchanger temperature sensor 2 abnormality	Continuous for 5s	—	Indoor heat exchanger temperature sensor 2 open or short circuit	<ul style="list-style-type: none"> <li>Indoor heat exchanger temperature sensor 2 lead wire and connector</li> </ul>
H25	Indoor ion device abnormality	Port is ON for 10s during ion device off	—	—	<ul style="list-style-type: none"> <li>ion device PCB</li> </ul>
H27	Outdoor air temperature sensor abnormality	Continuous for 5s	—	Outdoor air temperature sensor open or short circuit	<ul style="list-style-type: none"> <li>Outdoor air temperature sensor lead wire and connector</li> </ul>
H28	Outdoor heat exchanger temperature sensor 1 abnormality	Continuous for 5s	—	Outdoor heat exchanger temperature sensor 1 open or short circuit	<ul style="list-style-type: none"> <li>Outdoor heat exchanger temperature sensor 1 lead wire and connector</li> </ul>
H30	Outdoor discharge pipe temperature sensor abnormality	Continuous for 5s	—	Outdoor discharge pipe temperature sensor open or short circuit	<ul style="list-style-type: none"> <li>Outdoor discharge pipe temperature sensor lead wire and connector</li> </ul>
H32	Outdoor heat exchanger temperature sensor 2 abnormality	Continuous for 5s	—	Outdoor heat exchanger temperature sensor 2 open or short circuit	<ul style="list-style-type: none"> <li>Outdoor heat exchanger temperature sensor 2 lead wire and connector</li> </ul>
H33	Indoor / outdoor misconnection abnormality	—	—	Indoor and outdoor rated voltage different	<ul style="list-style-type: none"> <li>Indoor and outdoor units check</li> </ul>
H34	Outdoor heat sink temperature sensor abnormality	Continuous for 2s	—	Outdoor heat sink temperature sensor open or short circuit	<ul style="list-style-type: none"> <li>Outdoor heat sink sensor</li> </ul>
H36	Outdoor gas pipe temperature sensor abnormality	Continuous for 5s	Heating protection operation only	Outdoor gas pipe temperature sensor open or short circuit	<ul style="list-style-type: none"> <li>Outdoor gas pipe temperature sensor lead wire and connector</li> </ul>
H37	Outdoor liquid pipe temperature sensor abnormality	Continuous for 5s	Cooling protection operation only	Outdoor liquid pipe temperature sensor open or short circuit	<ul style="list-style-type: none"> <li>Outdoor liquid pipe temperature sensor lead wire and connector</li> </ul>
H38	Indoor/Outdoor mismatch (brand code)	—	—	Brand code not match	<ul style="list-style-type: none"> <li>Check indoor unit and outdoor unit</li> </ul>
H39	Abnormal indoor operating unit or standby units	3 times happen within 40 minutes	—	Wrong wiring and connecting pipe, expansion valve abnormality, indoor heat exchanger sensor open circuit	<ul style="list-style-type: none"> <li>Check indoor/outdoor connection wire and connection pipe</li> <li>Indoor heat exchanger sensor lead wire and connector</li> <li>Expansion valve and lead wire and connector</li> </ul>

Diagnosis display	Abnormality / Protection control	Abnormality Judgment	Protection Operation	Problem	Check location
H41	Abnormal wiring or piping connection	—	—	Wrong wiring and connecting pipe, expansion valve abnormality	<ul style="list-style-type: none"> <li>• Check indoor/outdoor connection wire and connection pipe</li> <li>• Expansion valve and lead wire and connector</li> </ul>
H59	ECONAVI sensor abnormality	Continuous for 25s	—	ECONAVI sensor open or short circuit	<ul style="list-style-type: none"> <li>• ECONAVI sensor (defective or disconnected)</li> <li>• ECONAVI PCB</li> </ul>
H64	Outdoor high pressure sensor abnormality	Continuous for 1 minutes	—	High pressure sensor open circuit during compressor stop	<ul style="list-style-type: none"> <li>• High pressure sensor</li> <li>• Lead wire and connector</li> </ul>
H67	Nanoe abnormality	Nanoe stop for 5 minutes for 3 times	—	Nanoe faulty	<ul style="list-style-type: none"> <li>• PCB</li> <li>• Nanoe system</li> <li>• High voltage</li> </ul>
H70	Light sensor abnormality	Continuous for 24 hours, 15 days	—	Light sensor open or short circuit	<ul style="list-style-type: none"> <li>• Light sensor (defective or disconnect)</li> </ul>
H85	Abnormal communication between indoor & wireless LAN module	Communication error for 10 minutes for 3 times	—	Wireless LAN LED Off or timer LED blinking	<ul style="list-style-type: none"> <li>• Network adaptor</li> <li>• Router</li> <li>• Network coverage</li> </ul>
H97	Outdoor fan motor mechanism lock	2 times happen within 30 minutes	—	Outdoor fan motor lock or feedback abnormal	<ul style="list-style-type: none"> <li>• Outdoor fan motor lead wire and connector</li> <li>• Fan motor lock or block</li> </ul>
H98	Indoor high pressure protection	—	—	Indoor high pressure protection (Heating)	<ul style="list-style-type: none"> <li>• Check indoor heat exchanger</li> <li>• Air filter dirty</li> <li>• Air circulation short circuit</li> </ul>
H99	Indoor operating unit freeze protection	—	—	Indoor freeze protection (Cooling)	<ul style="list-style-type: none"> <li>• Check indoor heat exchanger</li> <li>• Air filter dirty</li> <li>• Air circulation short circuit</li> </ul>
F11	4-way valve switching abnormality	4 times happen within 30 minutes	—	4-way valve switching abnormal	<ul style="list-style-type: none"> <li>• 4-way valve</li> <li>• Lead wire and connector</li> </ul>
F17	Indoor standby units freezing abnormality	3 times happen within 40 minutes	—	Wrong wiring and connecting pipe, expansion valve leakage, indoor heat exchanger sensor open circuit	<ul style="list-style-type: none"> <li>• Check indoor/outdoor connection wire and pipe</li> <li>• Indoor heat exchanger sensor lead wire and connector</li> <li>• Expansion valve lead wire and connector</li> </ul>
F90	Power factor correction (PFC) circuit protection	4 times happen within 10 minutes	—	Power factor correction circuit abnormal	<ul style="list-style-type: none"> <li>• Outdoor PCB faulty</li> </ul>
F91	Refrigeration cycle abnormality	2 times happen within 20 minutes	—	Refrigeration cycle abnormal	<ul style="list-style-type: none"> <li>• Insufficient refrigerant or valve close</li> </ul>
F93	Compressor abnormal revolution	4 times happen within 20 minutes	—	Compressor abnormal revolution	<ul style="list-style-type: none"> <li>• Power transistor module faulty or compressor lock</li> </ul>
F94	Compressor discharge overshoot protection	4 times happen within 30 minutes	—	Compressor discharge pressure overshoot	<ul style="list-style-type: none"> <li>• Check refrigeration system</li> </ul>
F95	Outdoor cooling high pressure protection	4 times happen within 20 minutes	—	Cooling high pressure protection	<ul style="list-style-type: none"> <li>• Check refrigeration system</li> <li>• Outdoor air circuit</li> </ul>
F96	Power transistor module overheating protection	4 times happen within 30 minutes	—	Power transistor module overheat	<ul style="list-style-type: none"> <li>• PCB faulty</li> <li>• Outdoor air circuit (fan motor)</li> </ul>
F97	Compressor overheating protection	3 times happen within 30 minutes	—	Compressor overheat	<ul style="list-style-type: none"> <li>• Insufficient refrigerant</li> </ul>
F98	Total running current protection	3 times happen within 20 minutes	—	Total current protection	<ul style="list-style-type: none"> <li>• Check refrigeration system</li> <li>• Power source or compressor lock</li> </ul>
F99	Outdoor direct current (DC) peak detection	Continuous happen for 7 times	—	Power transistor module current protection	<ul style="list-style-type: none"> <li>• Power transistor module faulty or compressor lock</li> </ul>

## 17.4 Self-diagnosis Method

### 17.4.1 H11 (Indoor/Outdoor Abnormal Communication)

#### Malfunction Decision Conditions

- During startup and operation of cooling and heating, the data received from outdoor unit in indoor unit signal transmission is checked whether it is normal.

#### Malfunction Caused

- Faulty indoor unit PCB.
- Faulty outdoor unit PCB.
- Indoor unit-outdoor unit signal transmission error due to wiring error.
- Indoor unit-outdoor unit signal transmission error due to breaking of wire in the connection wires between the indoor and outdoor units.

#### Troubleshooting

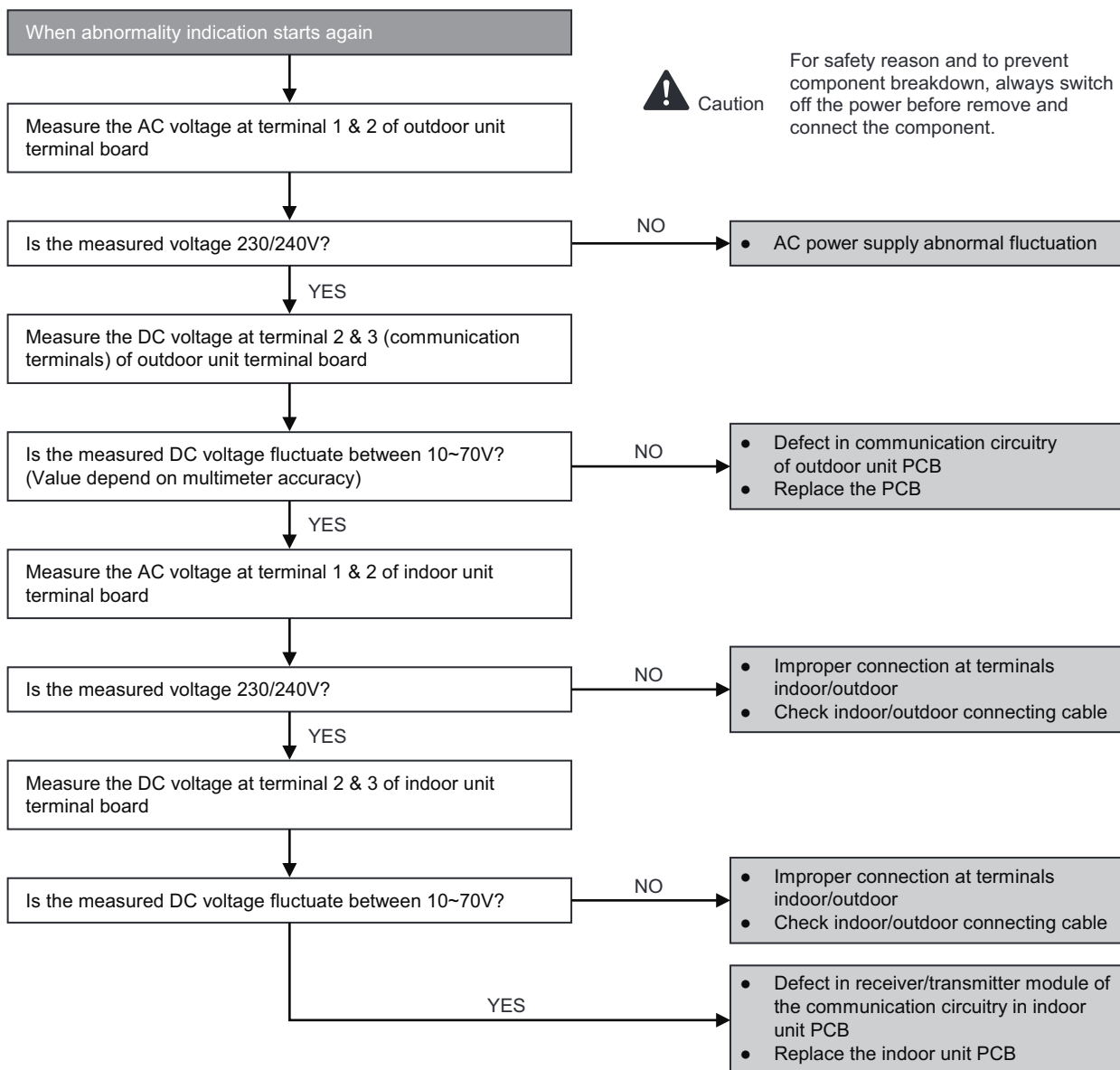

## 17.4.2 H12 (Indoor/Outdoor Capacity Rank Mismatched)

### Malfunction Decision Conditions

- During startup, error code appears when different types of indoor and outdoor units are interconnected.

### Malfunction Caused

- Wrong models interconnected.
- Wrong indoor unit or outdoor unit PCBs mounted.
- Indoor unit or outdoor unit PCBs defective.
- Indoor-outdoor unit signal transmission error due to wrong wiring.
- Indoor-outdoor unit signal transmission error due to breaking of wire 3 in the connection wires between the indoor and outdoor units.

### Troubleshooting

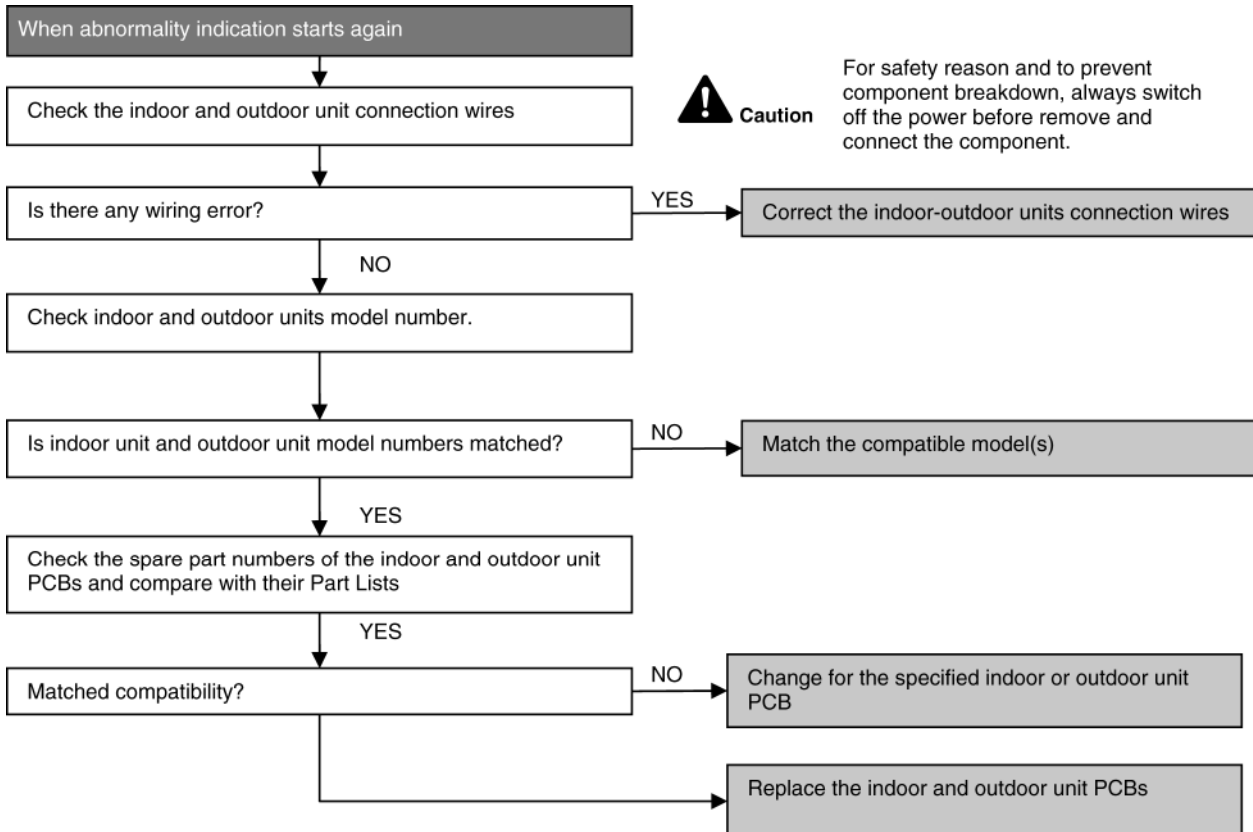

### 17.4.3 H14 (Indoor Intake Air Temperature Sensor Abnormality)

#### Malfunction Decision Conditions

- During startup and operation of cooling and heating, the temperatures detected by the indoor intake air temperature sensor are used to determine sensor errors.

#### Malfunction Caused

- Faulty connector connection.
- Faulty sensor.
- Faulty PCB.

#### Troubleshooting

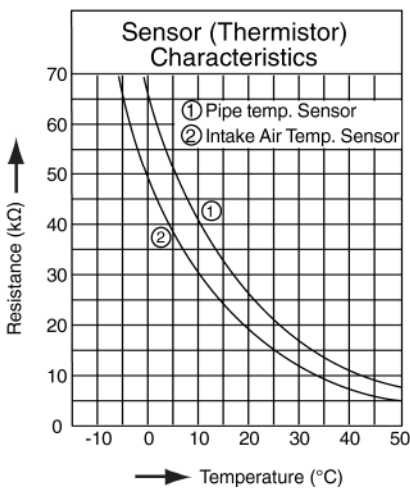
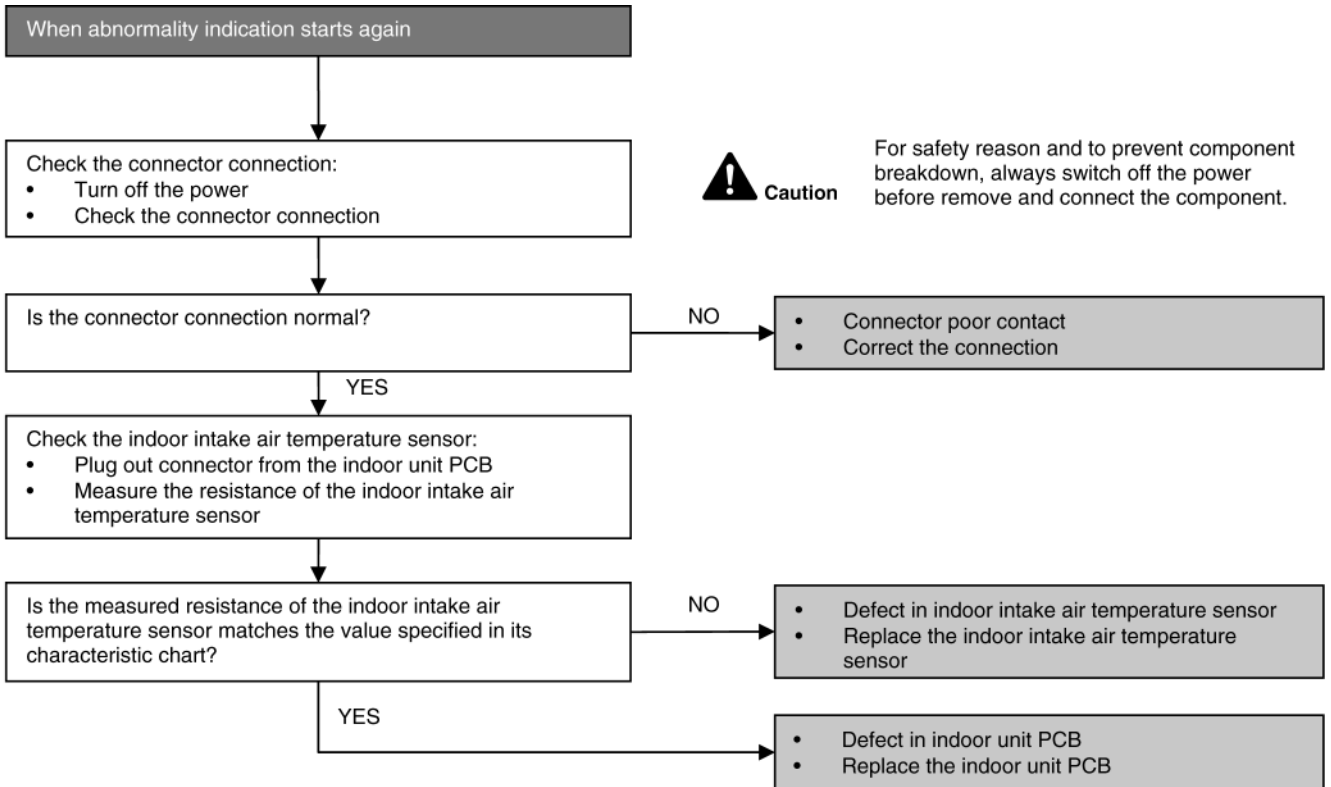

## 17.4.4 H15 (Compressor Temperature Sensor Abnormality)

### Malfunction Decision Conditions

- During startup and operation of cooling and heating, the temperatures detected by the outdoor compressor temperature sensor are used to determine sensor errors.

### Malfunction Caused

- Faulty connector connection.
- Faulty sensor.
- Faulty PCB.

### Troubleshooting

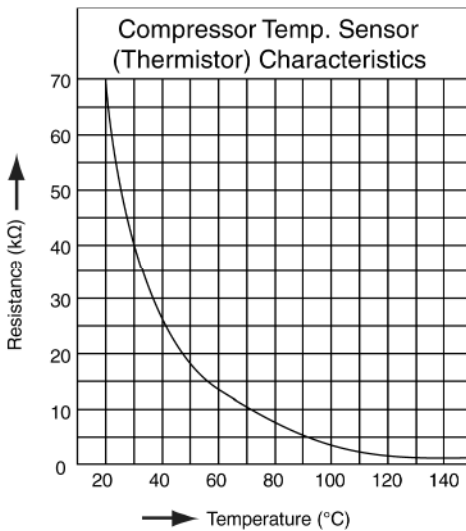
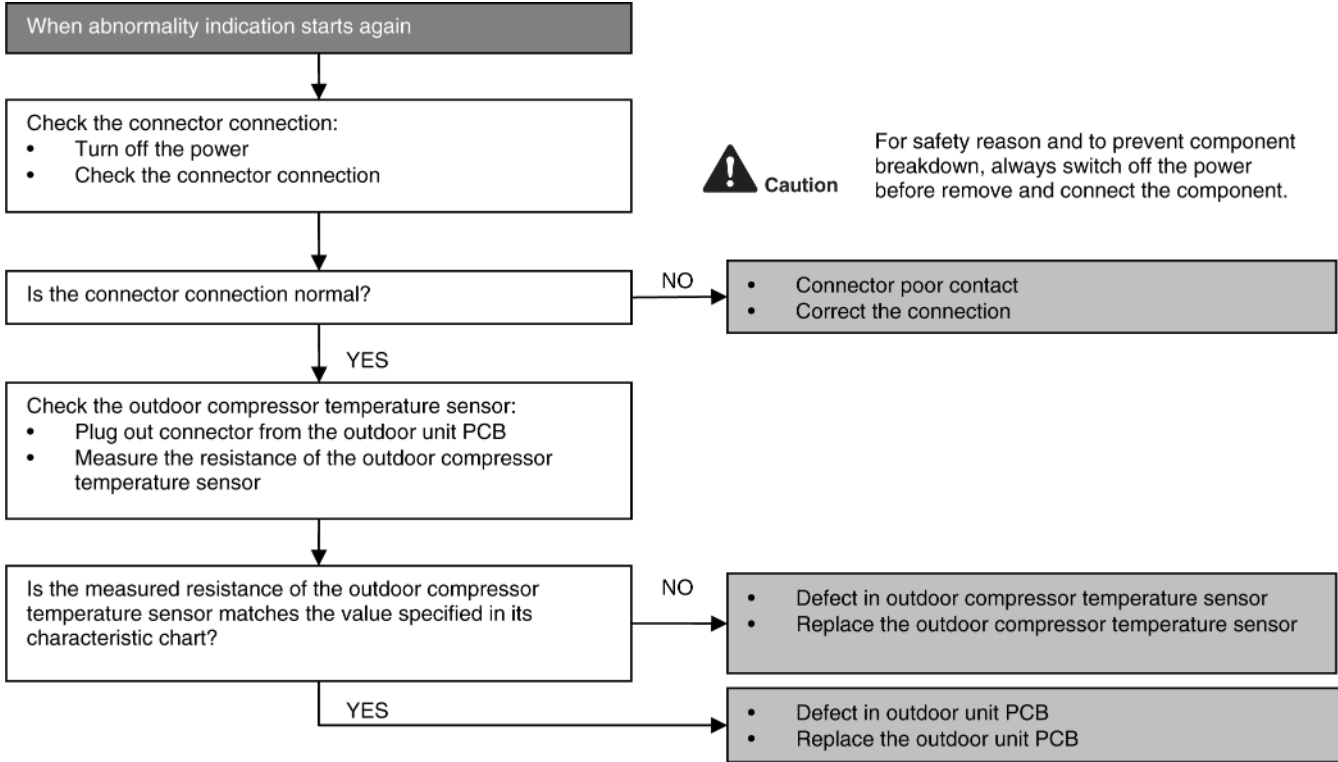

### 17.4.5 H16 (Outdoor Current Transformer)

#### Malfunction Decision Conditions

- An input current, detected by Current Transformer CT, is below threshold value when the compressor is operating at certain frequency value for 3 minutes.

#### Malfunction Caused

- Lack of gas
- Broken CT (current transformer)
- Broken Outdoor PCB

#### Troubleshooting

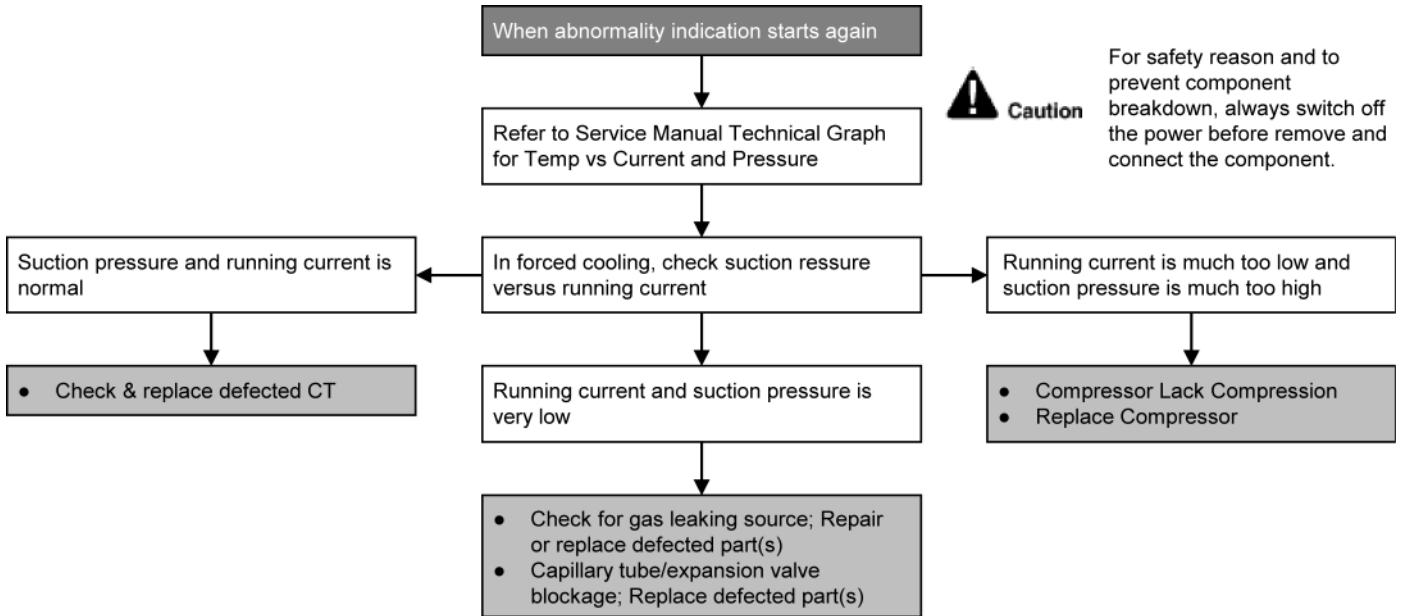

## 17.4.6 H19 (Indoor Fan Motor – DC Motor Mechanism Locked)

### Malfunction Decision Conditions

- The rotation speed detected by the Hall IC during fan motor operation is used to determine abnormal fan motor (feedback of rotation > 2550 rpm or < 50 rpm)

### Malfunction Caused

- Operation stops due to short circuit inside the fan motor winding.
- Operation stops due to breaking of wire inside the fan motor.
- Operation stops due to breaking of fan motor lead wires.
- Operation stops due to Hall IC malfunction.
- Operation error due to faulty indoor unit PCB.

### Troubleshooting

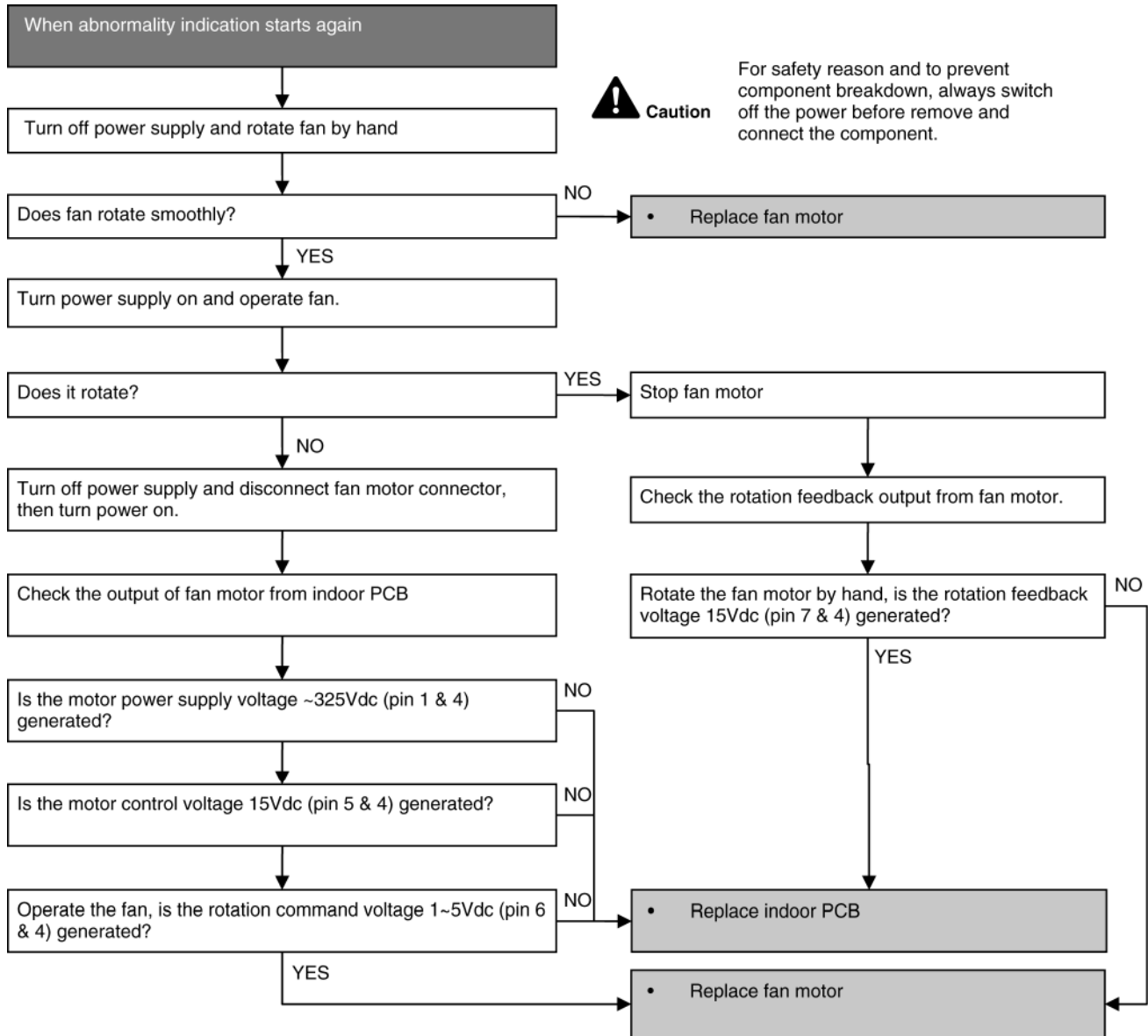

## 17.4.7 H23 (Indoor Pipe Temperature Sensor 1 Abnormality)

### Malfunction Decision Conditions

- During startup and operation of cooling and heating, the temperatures detected by the indoor heat exchanger temperature sensor are used to determine sensor errors.

### Malfunction Caused

- Faulty connector connection.
- Faulty sensor.
- Faulty PCB.

### Troubleshooting

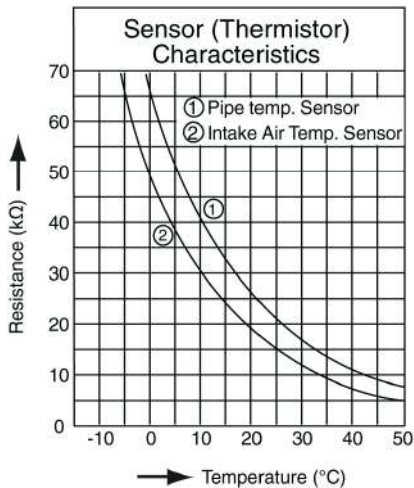
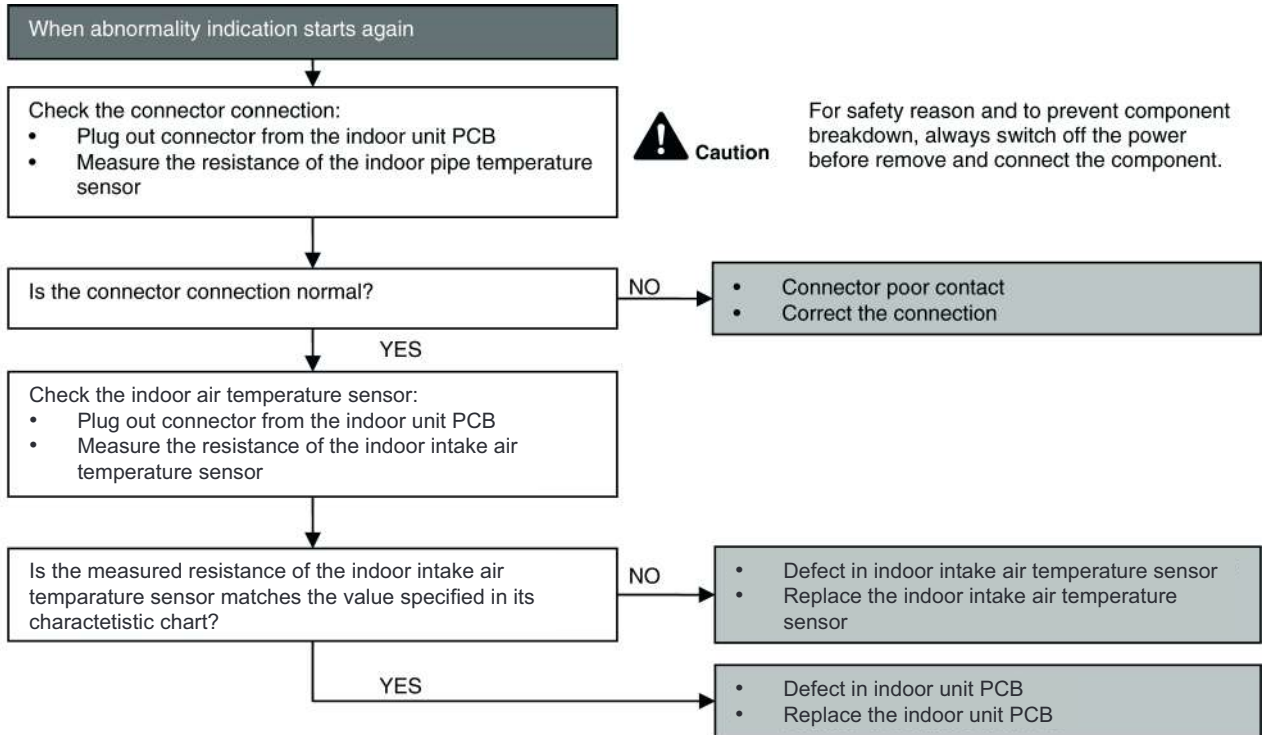

## 17.4.8 H24 (Indoor Pipe Temperature Sensor 2 Abnormality)

### Malfunction Decision Conditions

- During startup and operation of cooling and heating, the temperatures detected by the indoor heat exchanger temperature sensor are used to determine sensor errors.

### Malfunction Caused

- Faulty connector connection.
- Faulty sensor.
- Faulty PCB.

### Troubleshooting

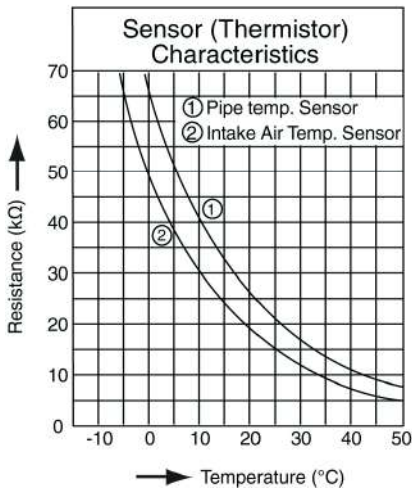
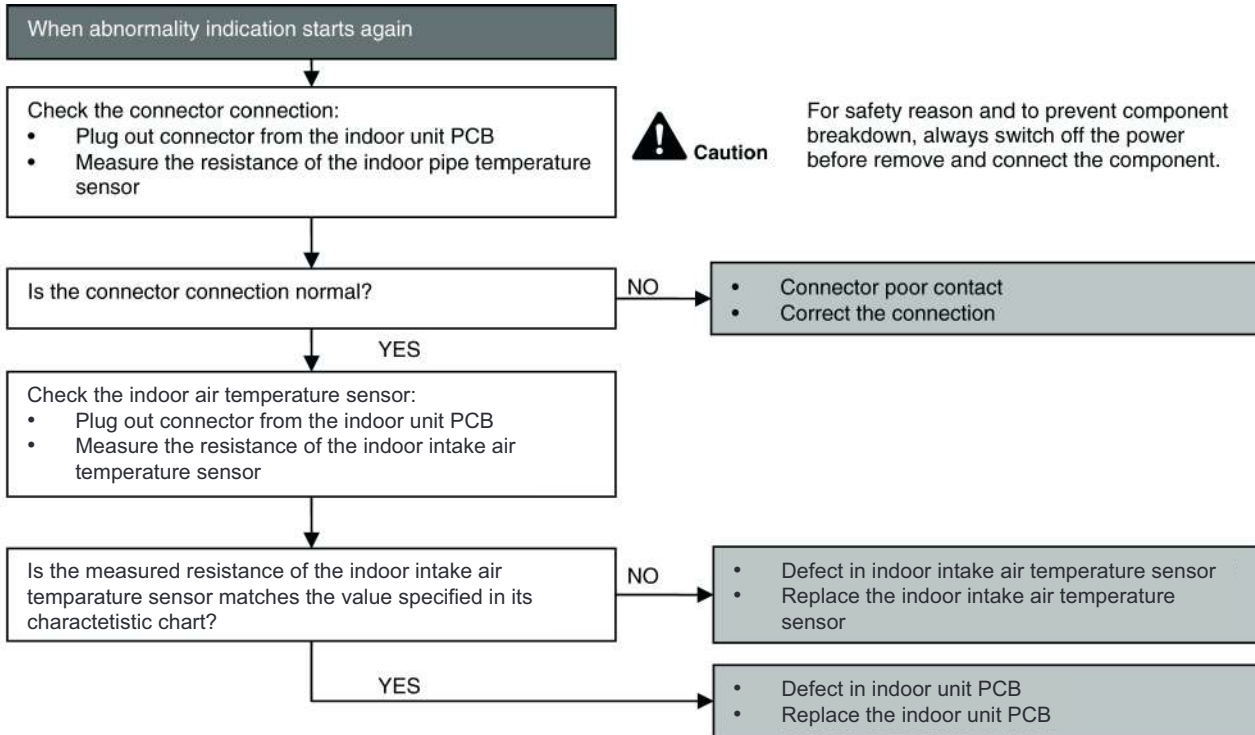

## 17.4.9 H27 (Outdoor Air Temperature Sensor Abnormality)

### Malfunction Decision Conditions

- During startup and operation of cooling and heating, the temperatures detected by the outdoor air temperature sensor are used to determine sensor errors.

### Malfunction Caused

- Faulty connector connection.
- Faulty sensor.
- Faulty PCB.

### Troubleshooting

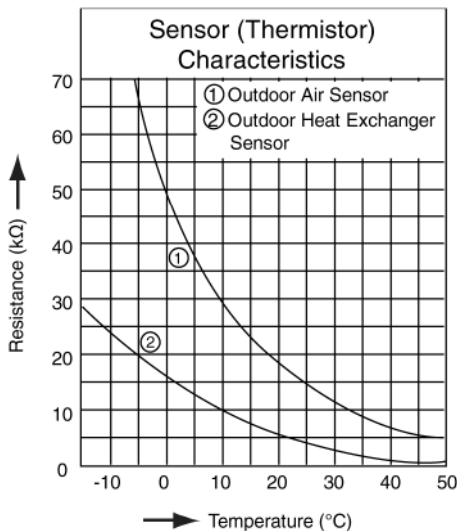
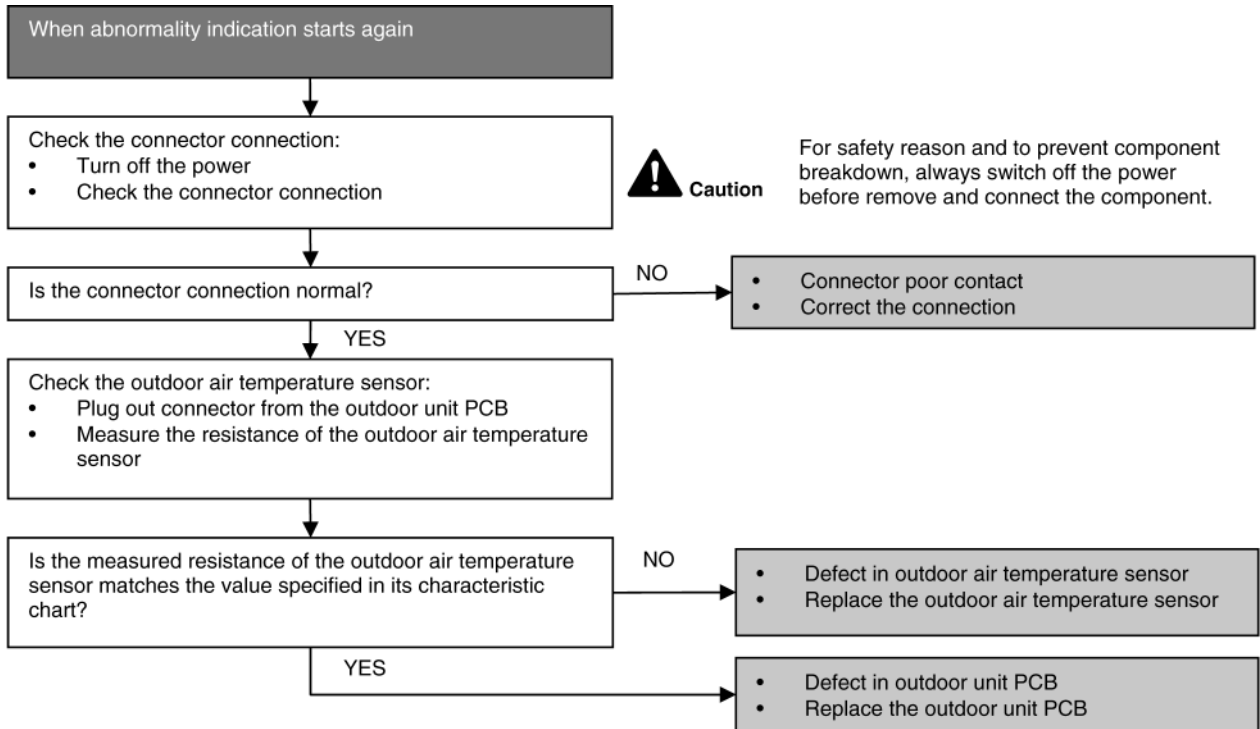

## 17.4.10 H28 (Outdoor Pipe Temperature Sensor Abnormality)

### Malfunction Decision Conditions

- During startup and operation of cooling and heating, the temperatures detected by the outdoor pipe temperature sensor are used to determine sensor errors.

### Malfunction Caused

- Faulty connector connection.
- Faulty sensor.
- Faulty PCB.

### Troubleshooting

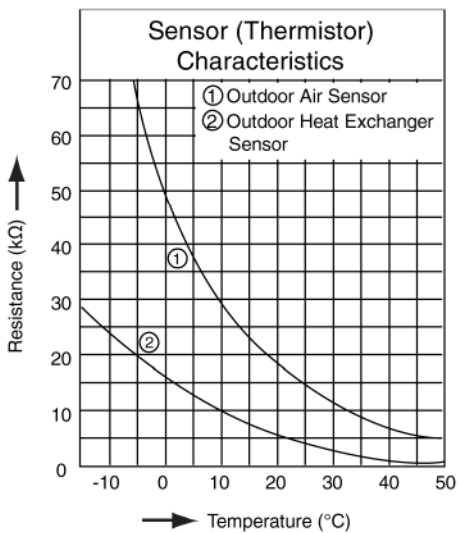
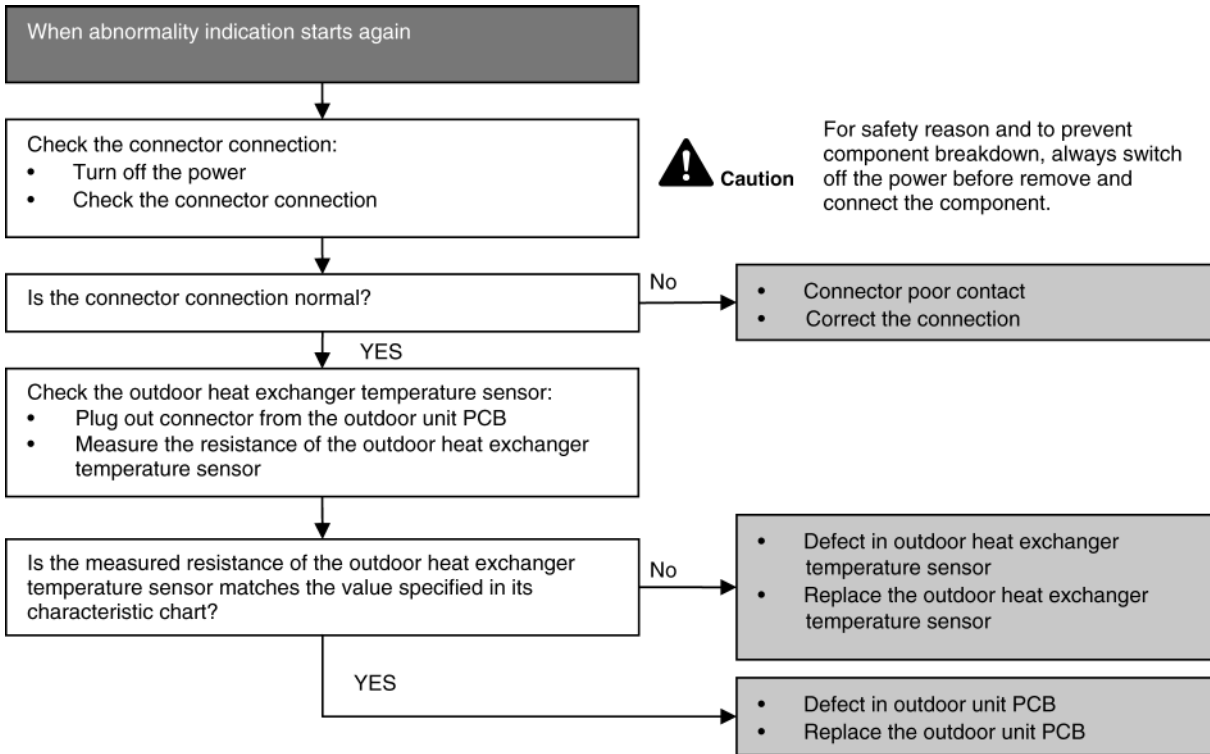

### 17.4.11 H30 (Compressor Discharge Temperature Sensor Abnormality)

#### Malfunction Decision Conditions

- During startup and operation of cooling and heating, the temperatures detected by the outdoor discharge pipe temperature sensor are used to determine sensor errors.

#### Malfunction Caused

- Faulty connector connection.
- Faulty sensor.
- Faulty PCB.

#### Troubleshooting

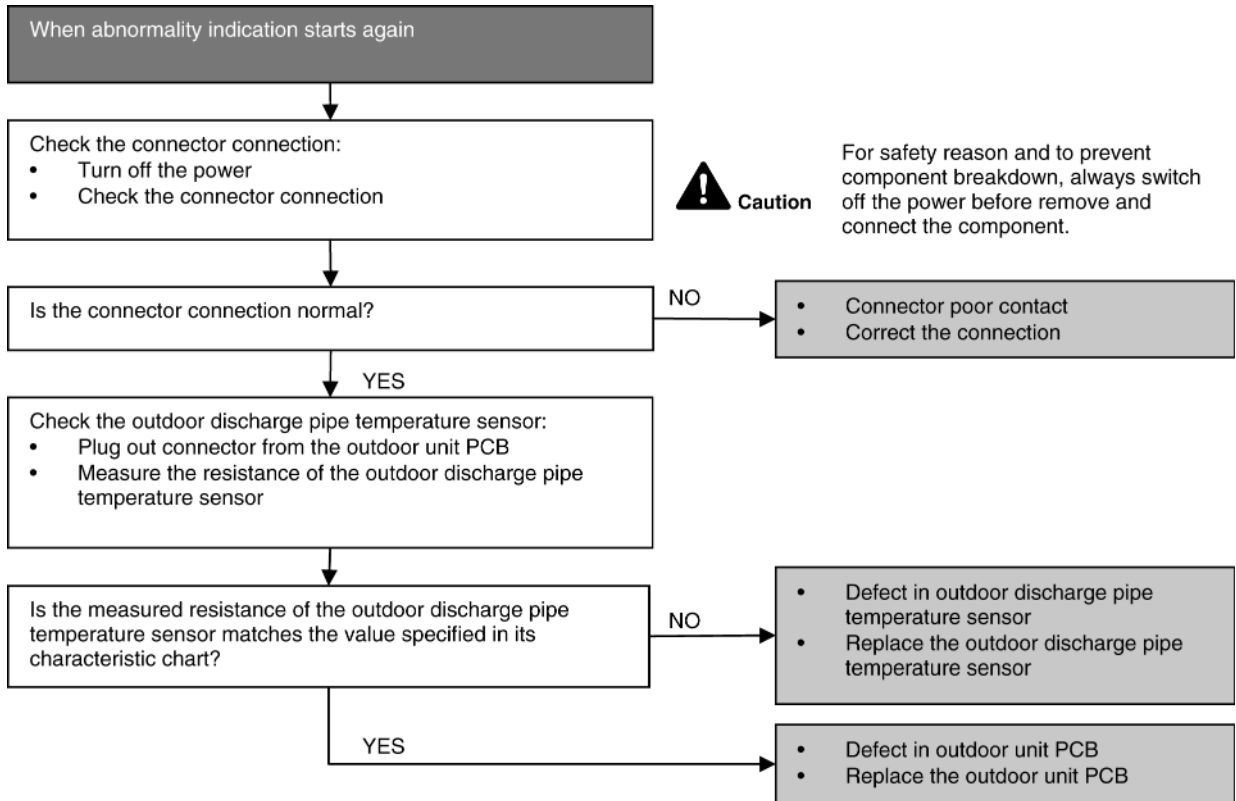

## 17.4.12 H32 (Outdoor Heat Exchanger Temperature Sensor 2 Abnormality)

### Malfunction Decision Conditions

- During startup and operation of cooling and heating, the temperatures detected by the outdoor heat exchanger temperature sensor are used to determine sensor errors.

### Malfunction Caused

- Faulty connector connection.
- Faulty sensor.
- Faulty PCB.

### Troubleshooting

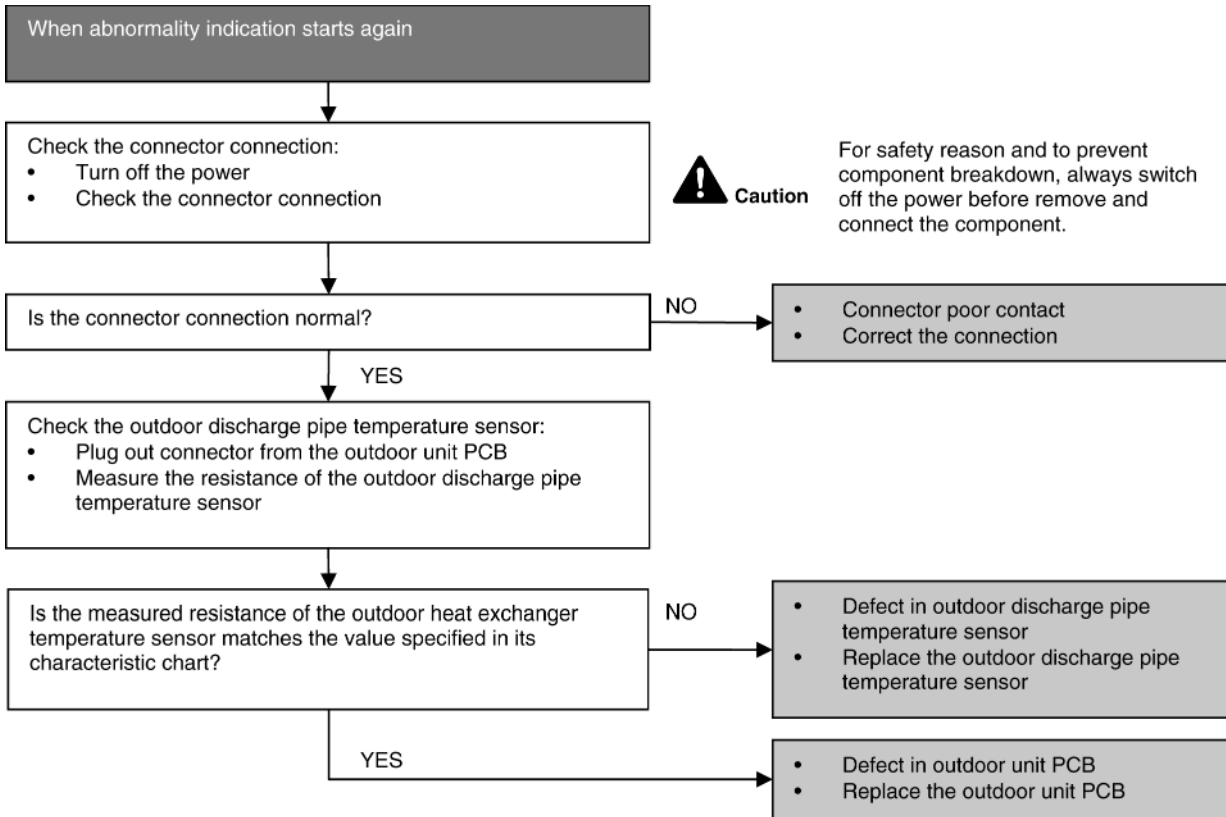

### 17.4.13 H33 (Unspecified Voltage between Indoor and Outdoor)

#### Malfunction Decision Conditions

- The supply power is detected for its requirement by the indoor/outdoor transmission.

#### Malfunction Caused

- Wrong models interconnected.
- Wrong indoor unit and outdoor unit PCBs used.
- Indoor unit or outdoor unit PCB defective.

#### Troubleshooting

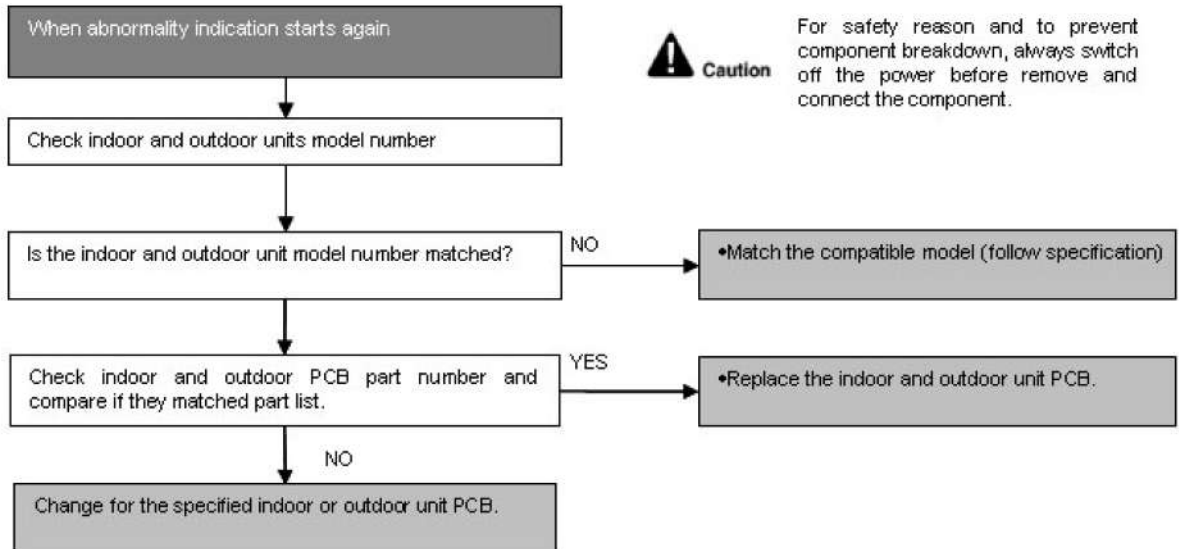

## 17.4.14 H34 (Outdoor Heat Sink Temperature Sensor Abnormality)

### Malfunction Decision Conditions

- During startup and operation of cooling and heating, the temperatures detected by the outdoor heat sink temperature sensor are used to determine sensor errors.

### Malfunction Caused

- Faulty connector connection.
- Faulty sensor.
- Faulty PCB.

### Troubleshooting

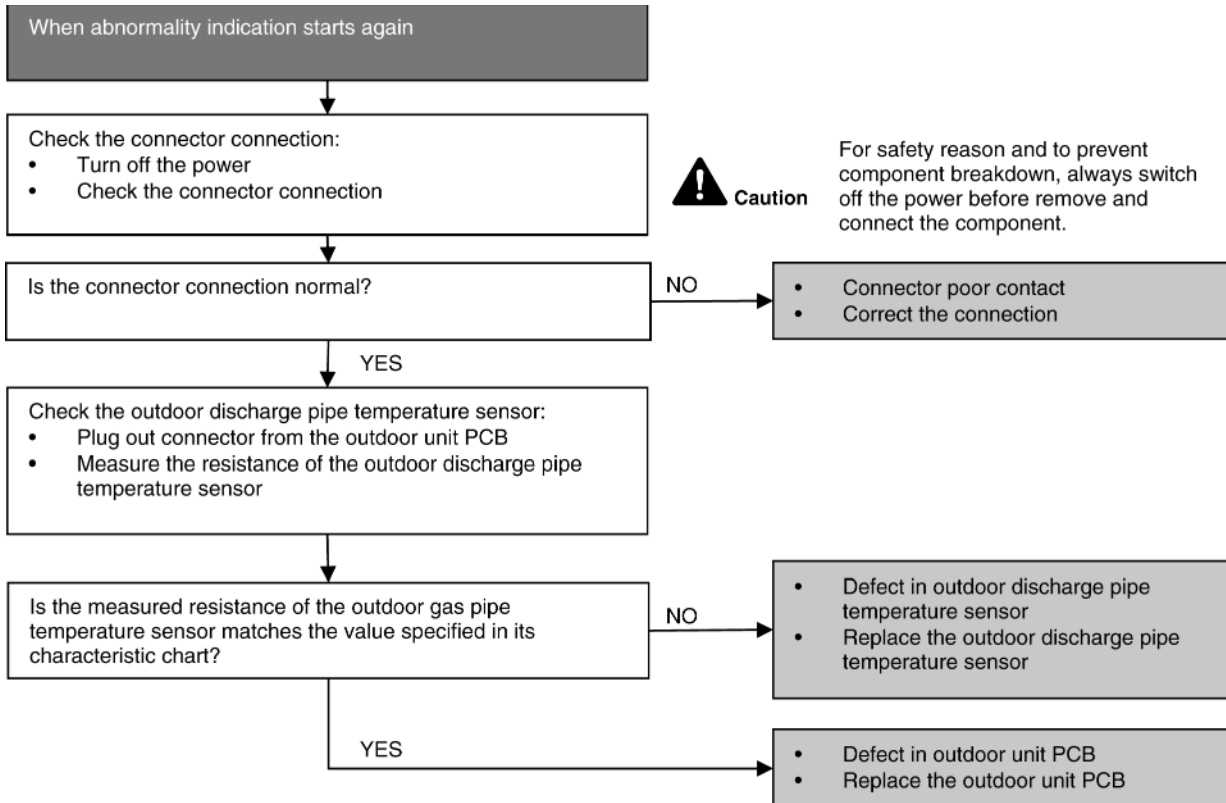

### 17.4.15 H36 (Outdoor Gas Pipe Sensor Abnormality)

#### Malfunction Decision Conditions

- During startup and operation of cooling and heating, the temperatures detected by the outdoor gas pipe temperature sensor are used to determine sensor errors.

#### Malfunction Caused

- Faulty connector connection.
- Faulty sensor.
- Faulty PCB.

#### Troubleshooting

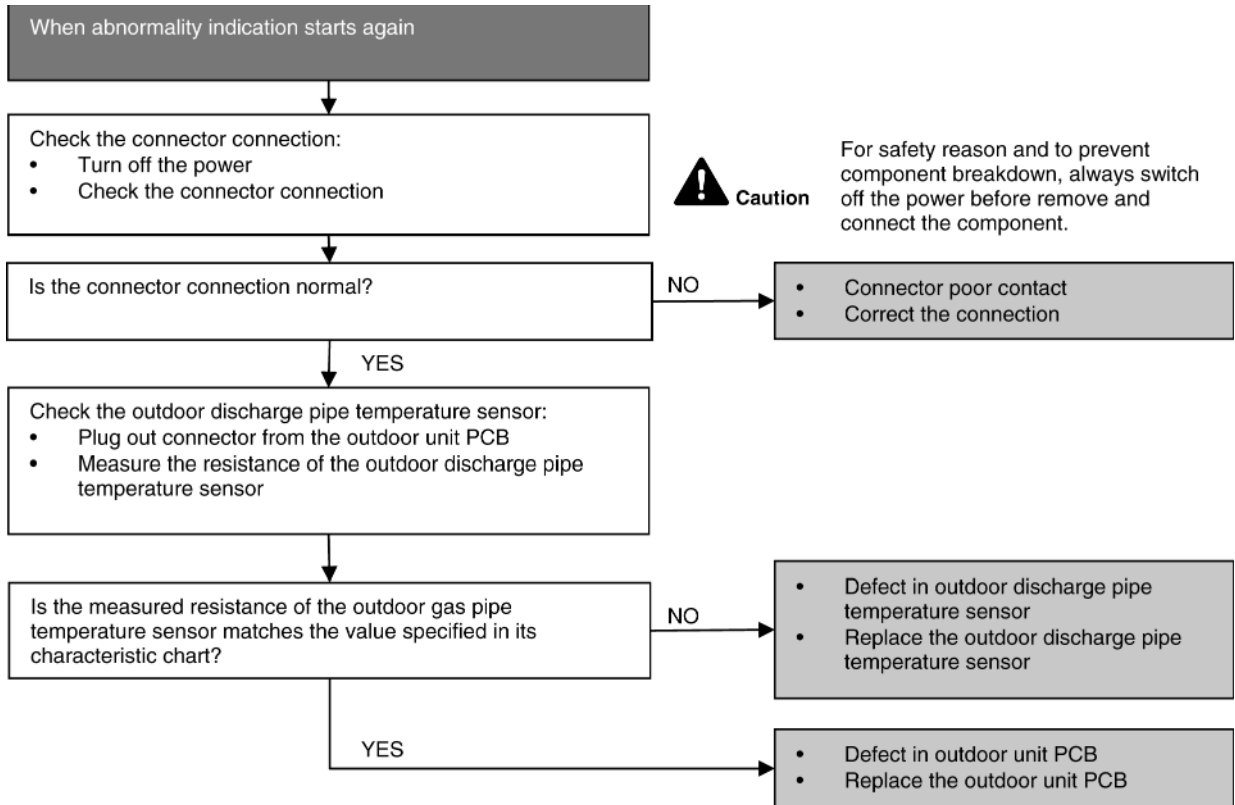

## 17.4.16 H37 (Outdoor Liquid Pipe Temperature Sensor Abnormality)

### Malfunction Decision Conditions

- During startup and operation of cooling and heating, the temperatures detected by the outdoor liquid pipe temperature sensor are used to determine sensor errors.

### Malfunction Caused

- Faulty connector connection.
- Faulty sensor.
- Faulty PCB.

### Troubleshooting

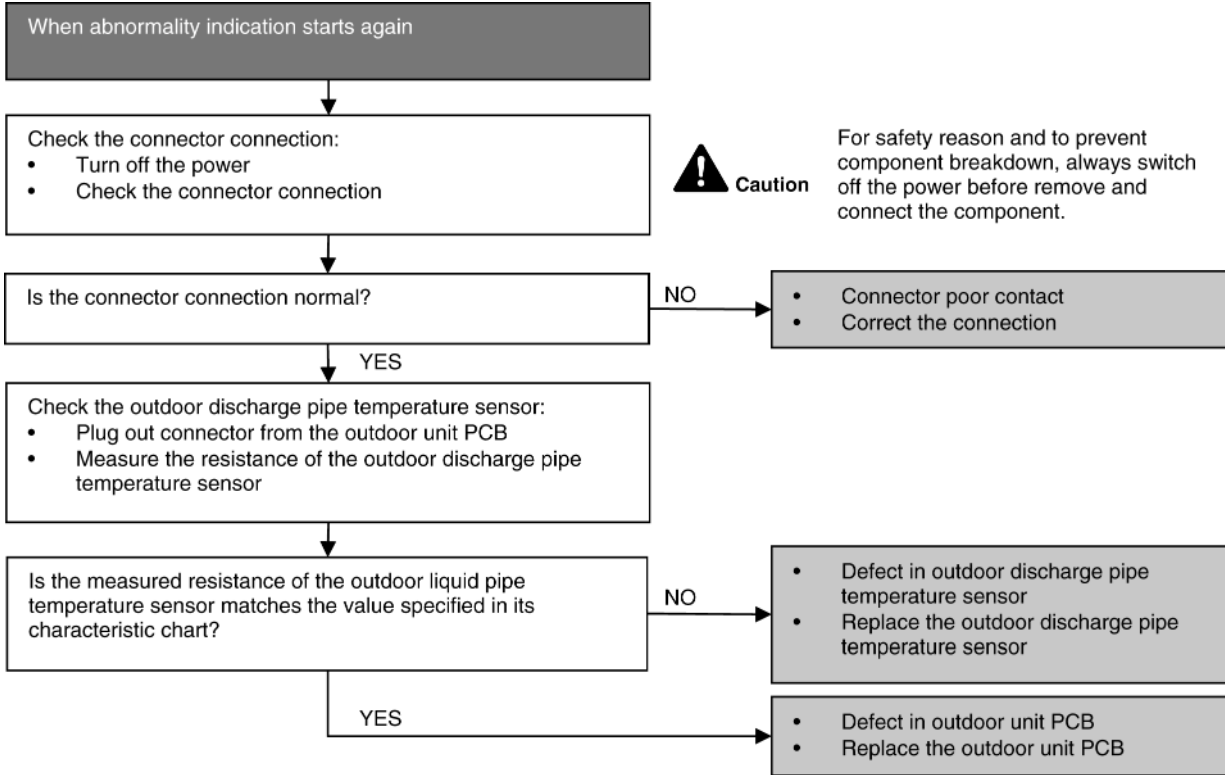

## 17.4.17 H85 (WLAN Module abnormality)

### Malfunction Decision Conditions

- Initial Setting: Main PCB does not receive WLAN module data for 90 secs.
- Normal Control: Main PCB does not receive WLAN module data for 10 mins repeating 2 times.
  - 5V power to WLAN module is turned off for 2s.
  - After 2s, 5V power to WLAN module is turned on & start initial setting.
  - WLAN LED Off & Timer LED blinking.

### Malfunction Caused

- Faulty lead wire connector connection.
- Faulty indoor unit PCB.
- Faulty WLAN module.

### Troubleshooting

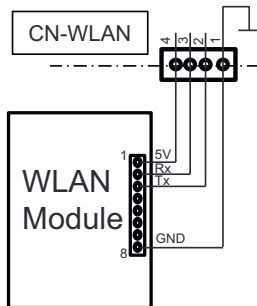
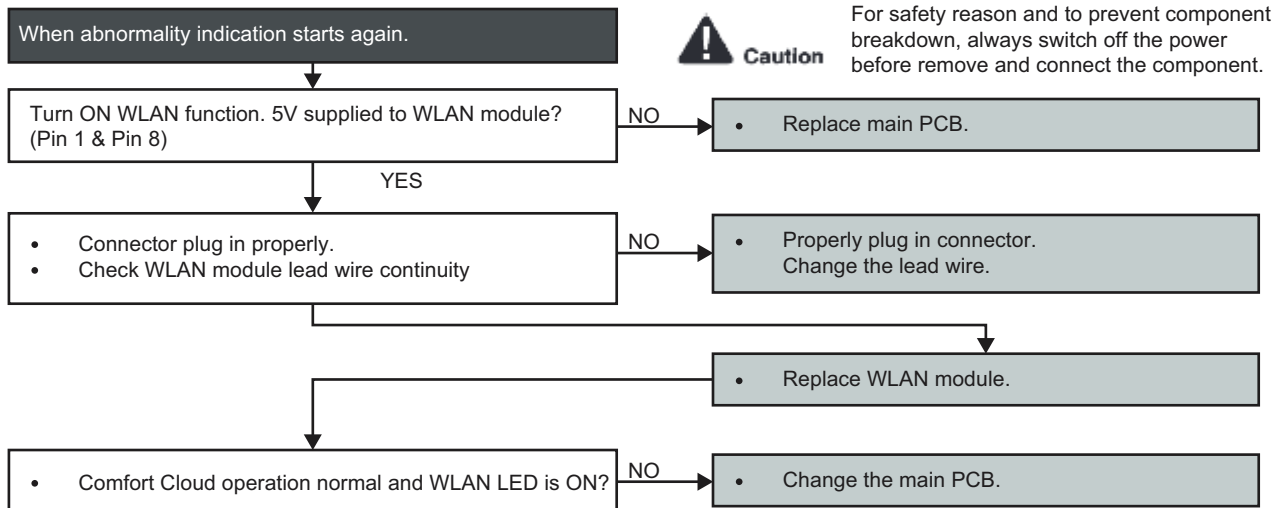

## 17.4.18 H97 (Outdoor Fan Motor – DC Motor Mechanism Locked)

### Malfunction Decision Conditions

- The rotation speed detected by the Hall IC during fan motor operation is used to determine abnormal fan motor.

### Malfunction Caused

- Operation stops due to short circuit inside the fan motor winding.
- Operation stops due to breaking of wire inside the fan motor.
- Operation stops due to breaking of fan motor lead wires.
- Operation stops due to Hall IC malfunction.
- Operation error due to faulty outdoor unit PCB.

### Troubleshooting

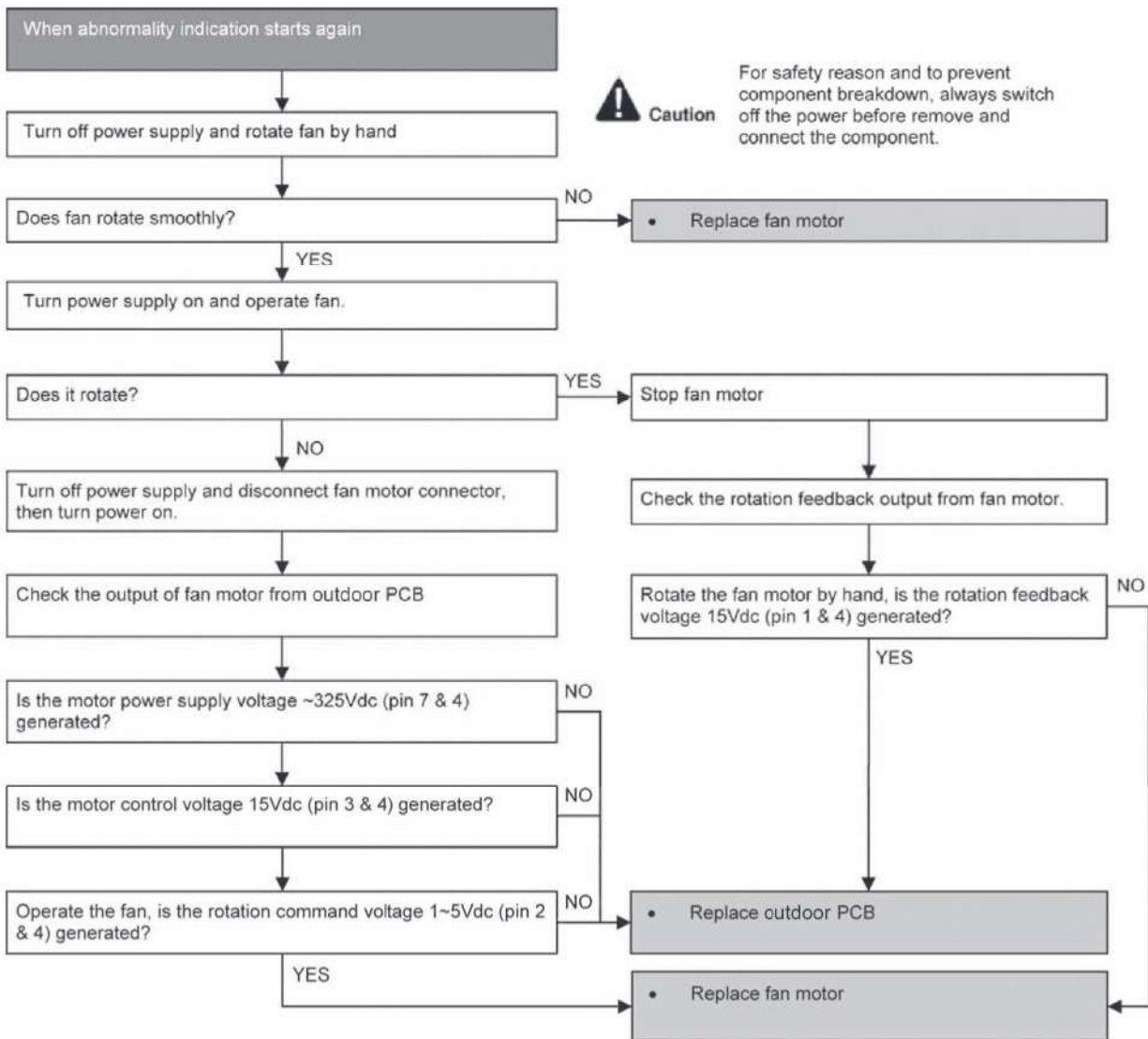

## 17.4.19 H98 (Error Code Stored in Memory and no alarm is triggered / no TIMER LED flashing)

### Malfunction Decision Conditions

- Indoor high pressure is detected when indoor heat exchanger is detecting very high temperature when the unit is operating in heating operation.
- Phenomena: unit is stopping and re-starting very often in heating mode

### Malfunction Caused

- Indoor heat exchanger thermistor
- Clogged air filter or heat exchanger
- Over-bent pipe (liquid side)

### Troubleshooting

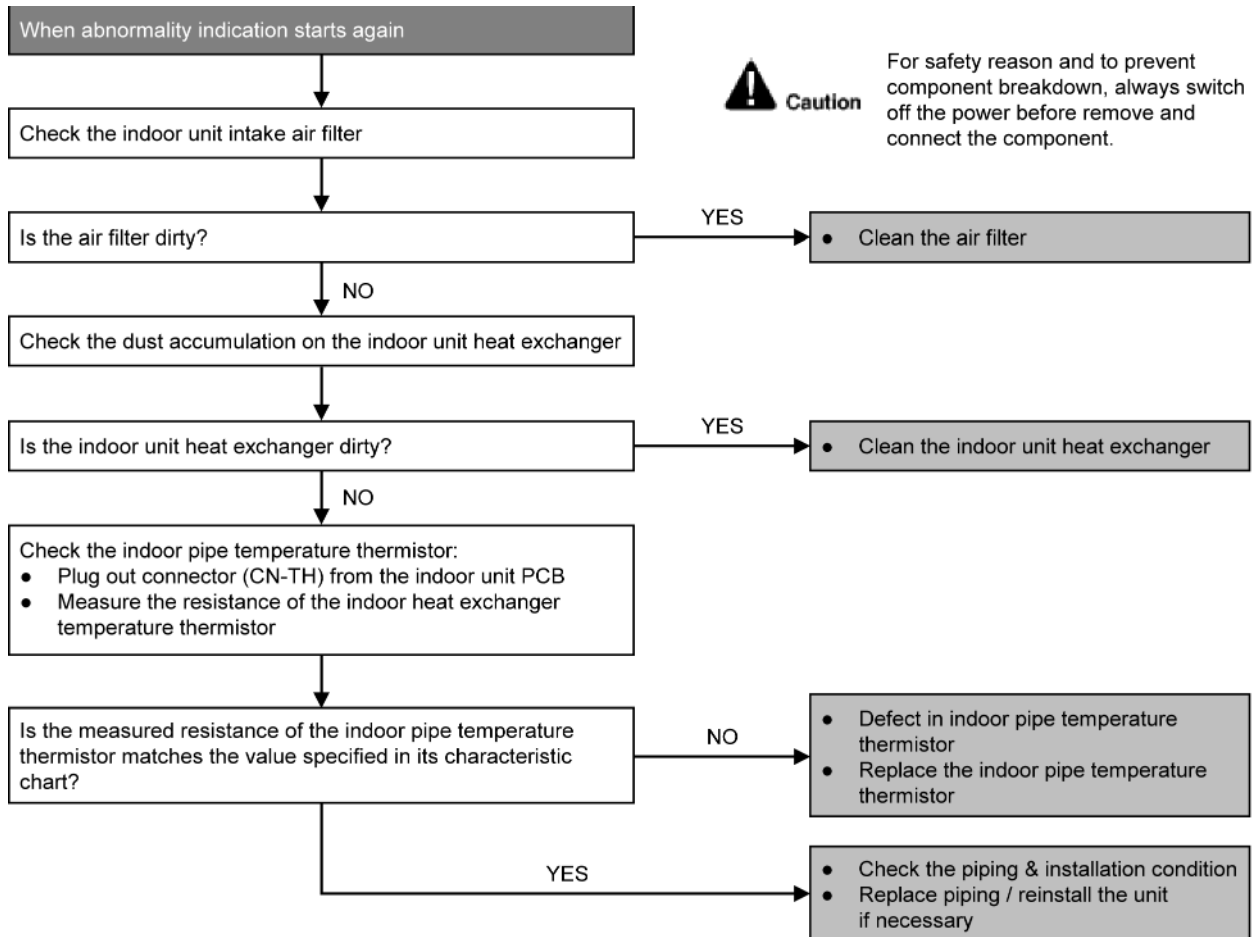

## 17.4.20 H99 (Indoor Freeze Prevention Protection: Cooling or Soft Dry)

Error Code will not display (no Timer LED blinking) but store in EEPROM

### Malfunction Decision Conditions

- Freeze prevention control takes place (when indoor pipe temperature is lower than 2°C)

### Malfunction Caused

- Air short circuit at indoor unit
- Clogged indoor unit air filter
- Dust accumulation on the indoor unit heat exchanger
- 2/3 way valve closed
- Faulty indoor unit fan motor
- Refrigerant shortage (refrigerant leakage)
- Clogged expansion valve or strainer
- Faulty indoor pipe temperature sensor
- Faulty indoor unit PCB

### Troubleshooting

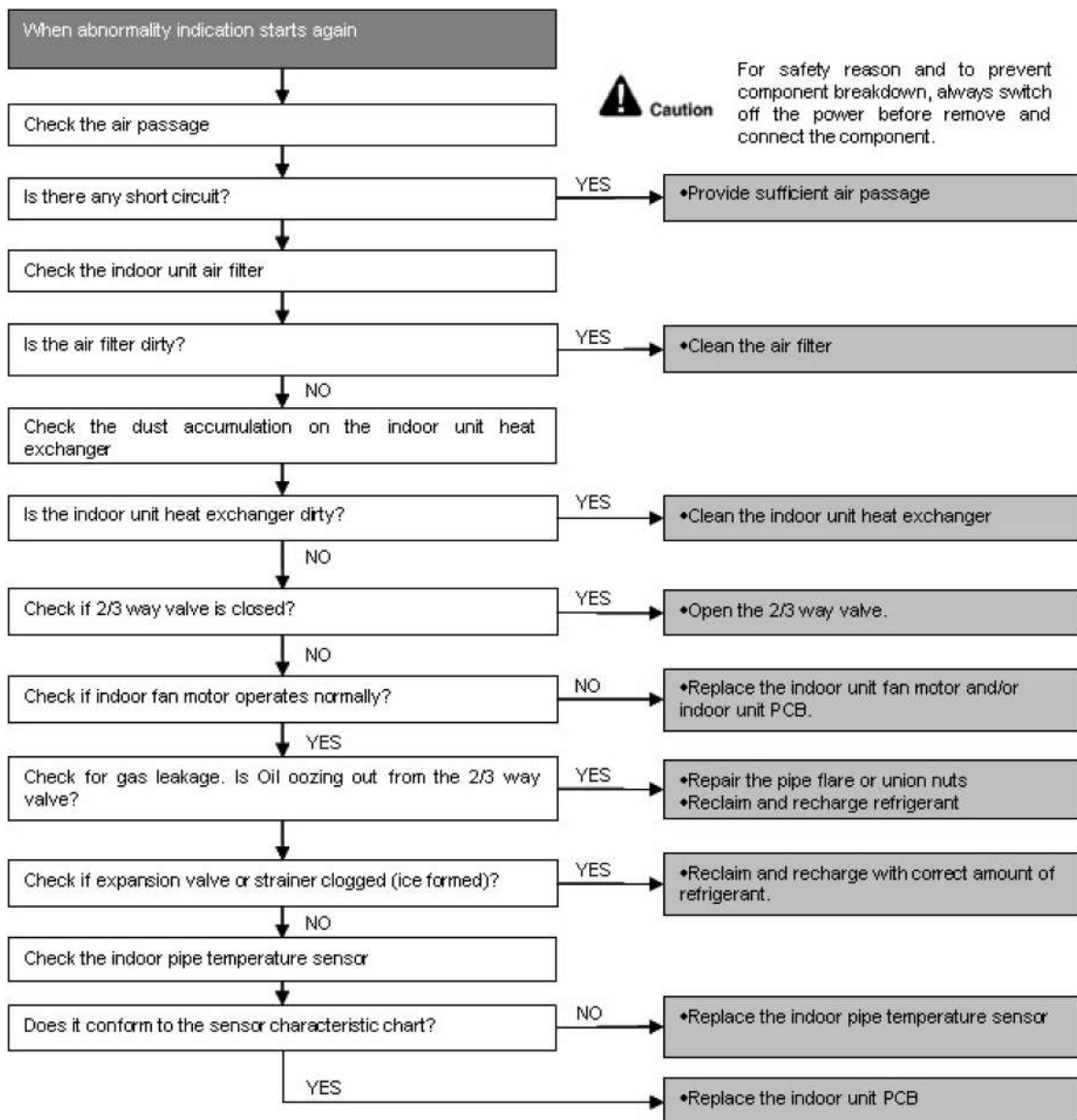

## 17.4.21 F11 (4-way Valve Switching Failure)

### Malfunction Decision Conditions

- When indoor heat exchanger is cold during heating (except deice) or when indoor heat exchanger is hot during cooling and compressor operating, the 4-way valve is detected as malfunction.

### Malfunction Caused

- Indoor heat exchanger (pipe) thermistor
- 4-way valve malfunction

### Troubleshooting

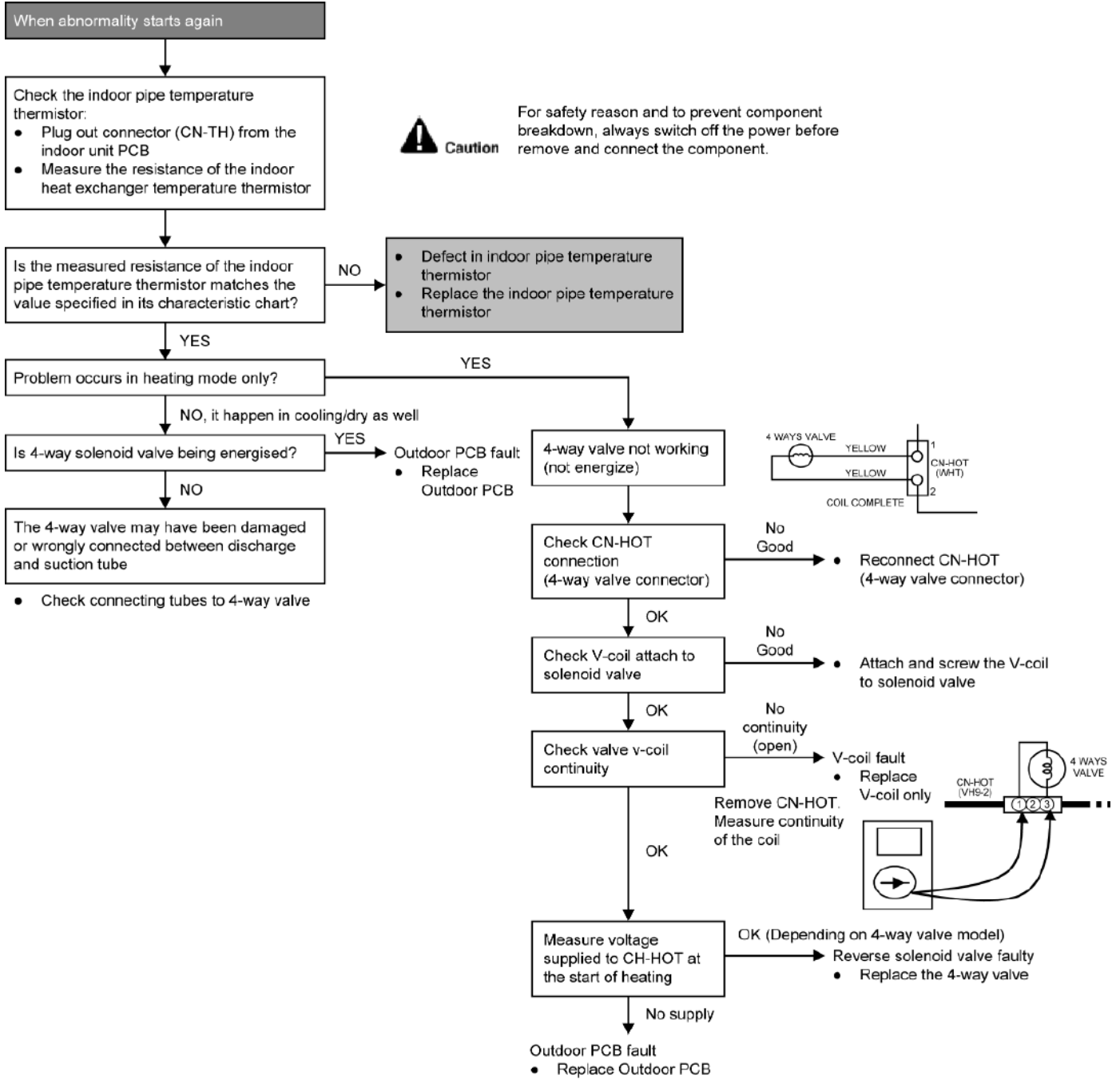

\* Check gas side pipe – for hot gas flow in cooling mode

## 17.4.22 F17 (Indoor Standby Units Freezing Abnormality)

### Malfunction Decision Conditions

- When the different between indoor intake air temperature and indoor pipe temperature is above 10°C or indoor pipe temperature is below -1.0°C.

### Remark:

When the indoor standby unit is freezing, the outdoor unit transfers F17 error code to the corresponding indoor unit and H39 to other indoor unit(s).

### Malfunction Caused

- Wrong wiring connection
- Faulty sensor
- Faulty expansion valve

### Troubleshooting

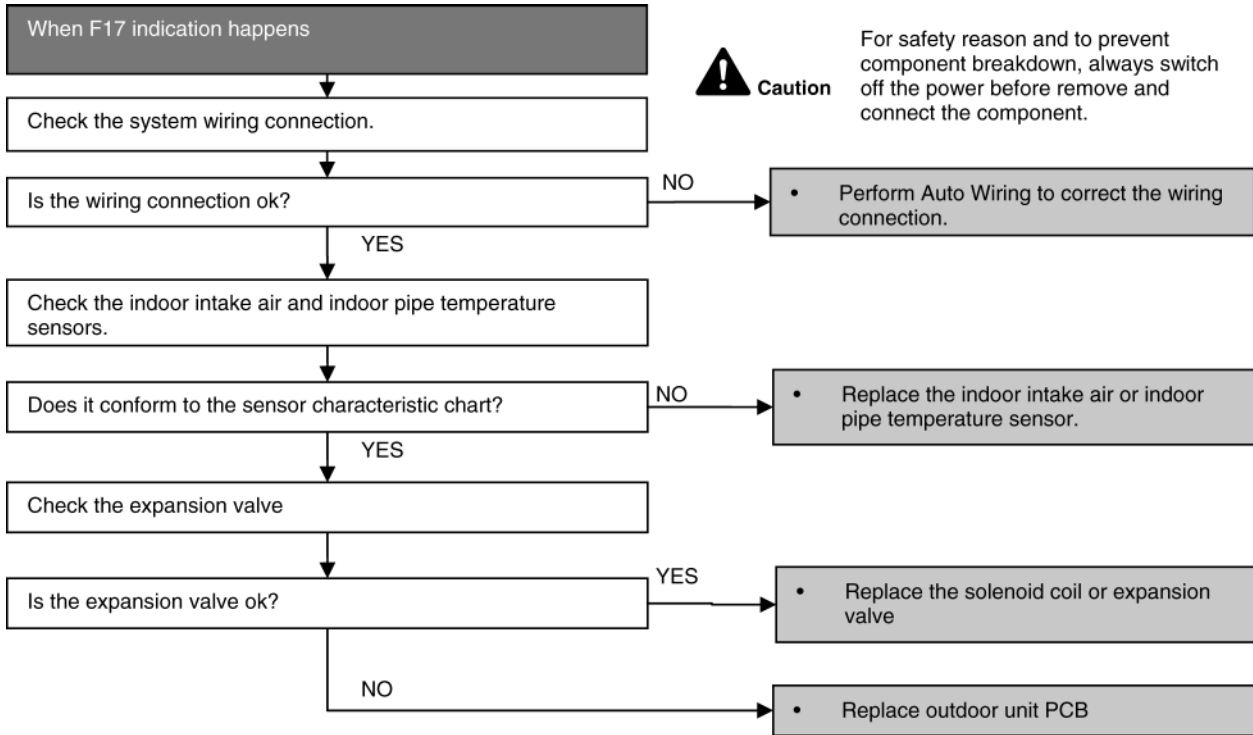

### 17.4.23 F90 (Power Factor Correction Protection)

#### Malfunction Decision Conditions

- To maintain DC voltage level supply to power transistor.
- To detect high DC voltage level after rectification.

#### Malfunction Caused

- During startup and operation of cooling and heating, when Power Factor Correction (PFC) protection circuitry at the outdoor unit main PCB senses abnormal DC voltage level for power transistors.
- When DC voltage detected is LOW, transistor switching will turn ON by controller to push-up the DC level.
- When DC voltage detected is HIGH (391Vdc – 425Vdc), active LOW signal will send by the controller to turn OFF relay RY-C.

#### Troubleshooting

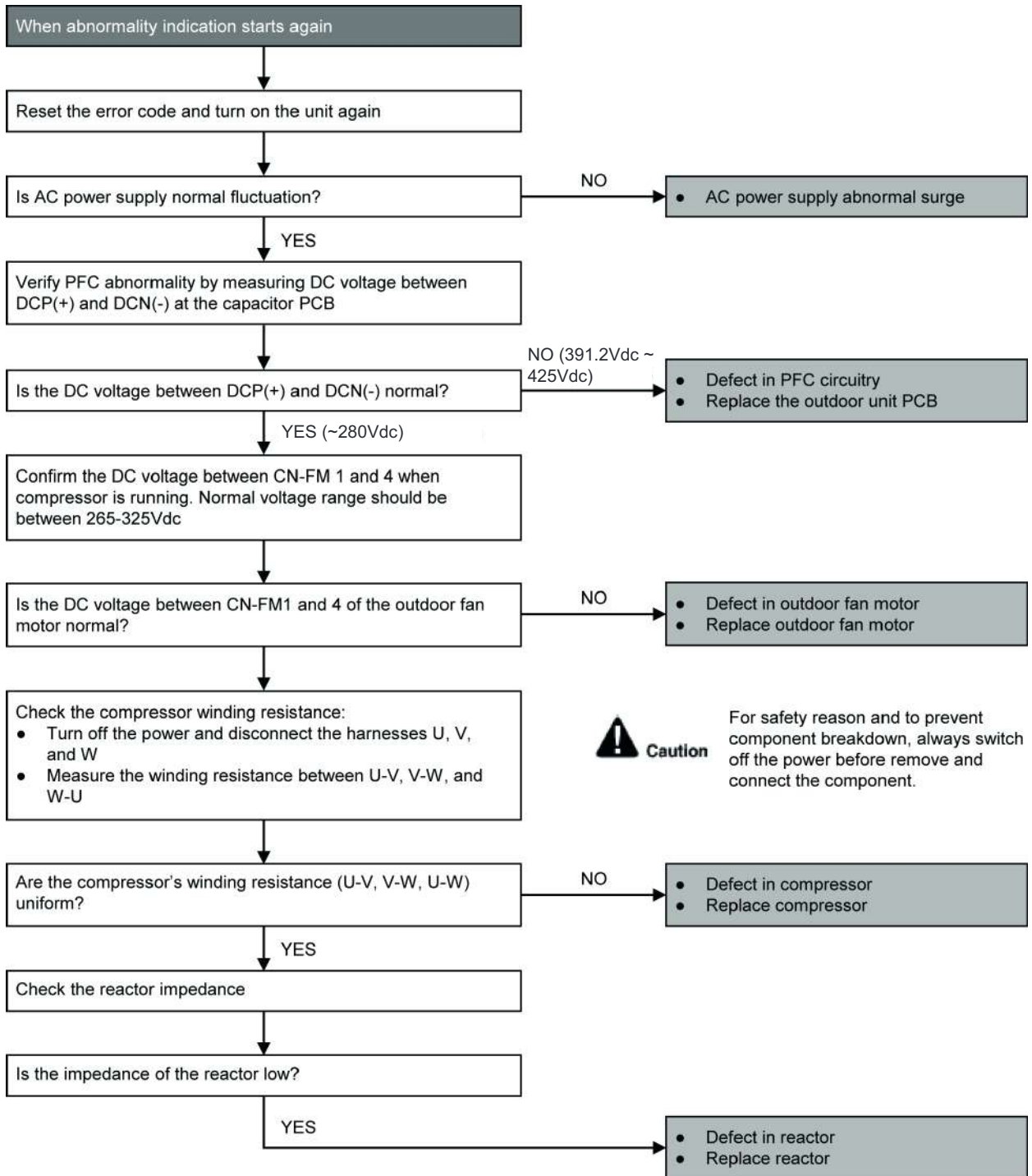

## 17.4.24 F91 (Refrigeration Cycle Abnormality)

### Malfunction Decision Conditions

- The input current is low while the compressor is running at higher than the setting frequency.

### Malfunction Caused

- Lack of gas.
- 3-way valve close.

### Troubleshooting

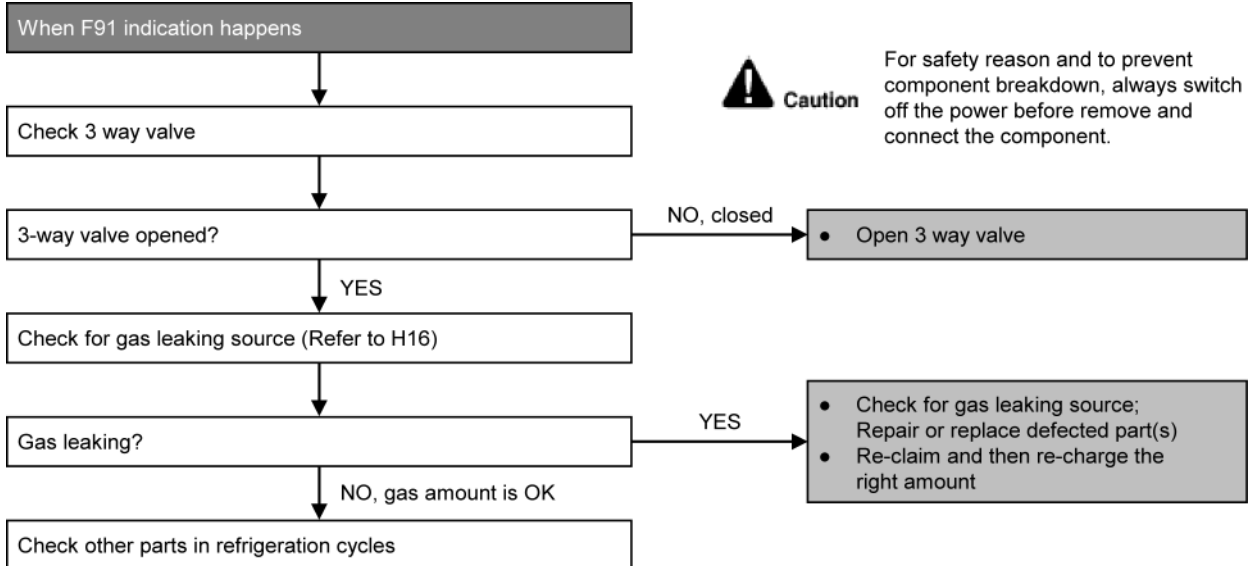

## 17.4.25 F93 (Compressor Rotation Failure)

### Malfunction Decision Conditions

- A compressor rotation failure is detected by checking the compressor running condition through the position detection circuit.

### Malfunction Caused

- Compressor terminal disconnect
- Faulty Outdoor PCB
- Faulty compressor

### Troubleshooting

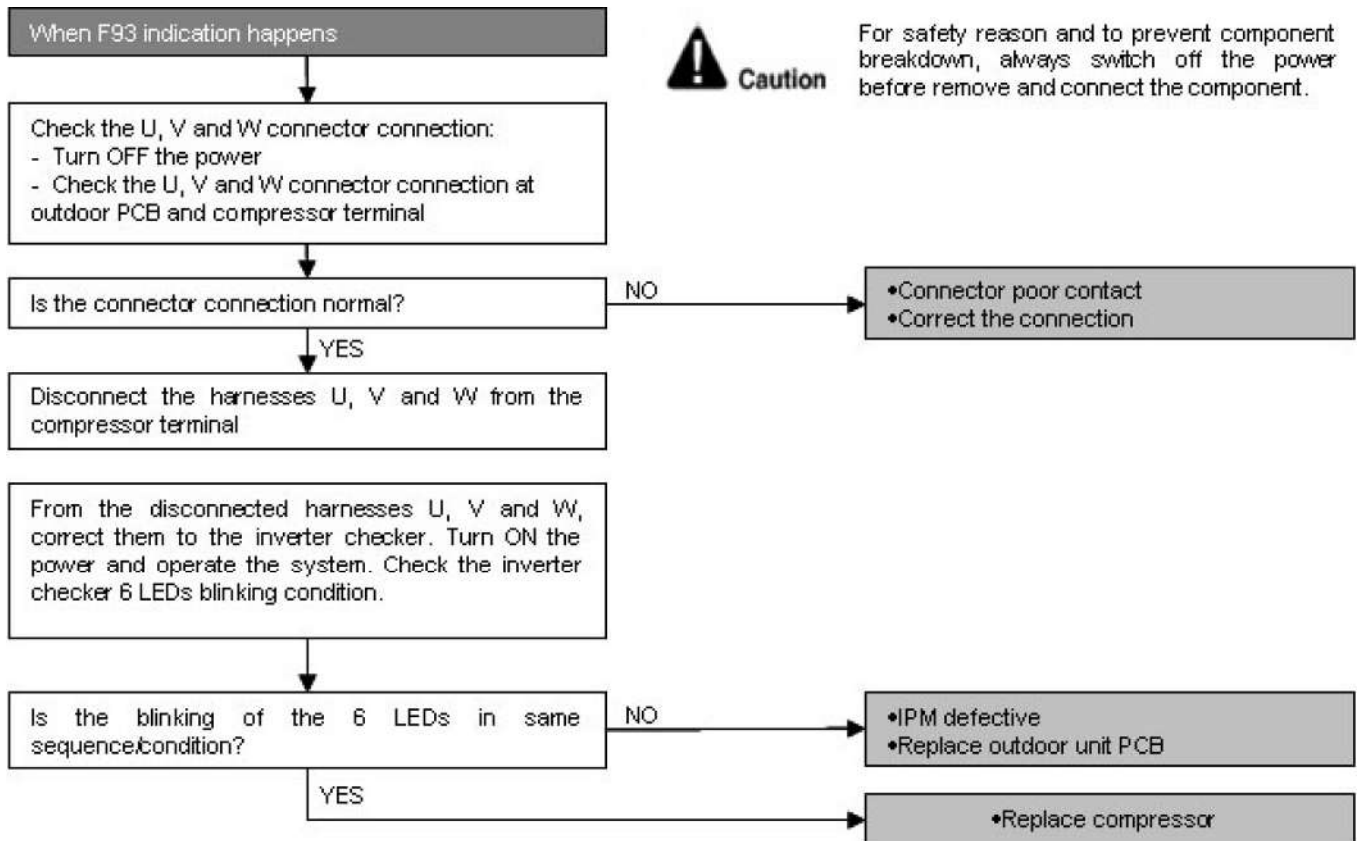

## 17.4.26 F95 (Outdoor High Pressure Protection: Cooling or Soft Dry)

### Malfunction Decision Conditions

- During operation of cooling or soft dry, when outdoor unit heat exchanger high temperature data is detected by the outdoor unit heat exchanger thermistor.

### Malfunction Caused

- Outdoor heat exchanger temperature rise due to short-circuit of hot discharge air flow.
- Outdoor heat exchanger temperature rise due to defective of outdoor fan motor.
- Outdoor heat exchange temperature rise due to defective outdoor heat exchanger thermistor.
- Outdoor heat exchanger temperature rise due to defective of outdoor unit PCB.

### Troubleshooting

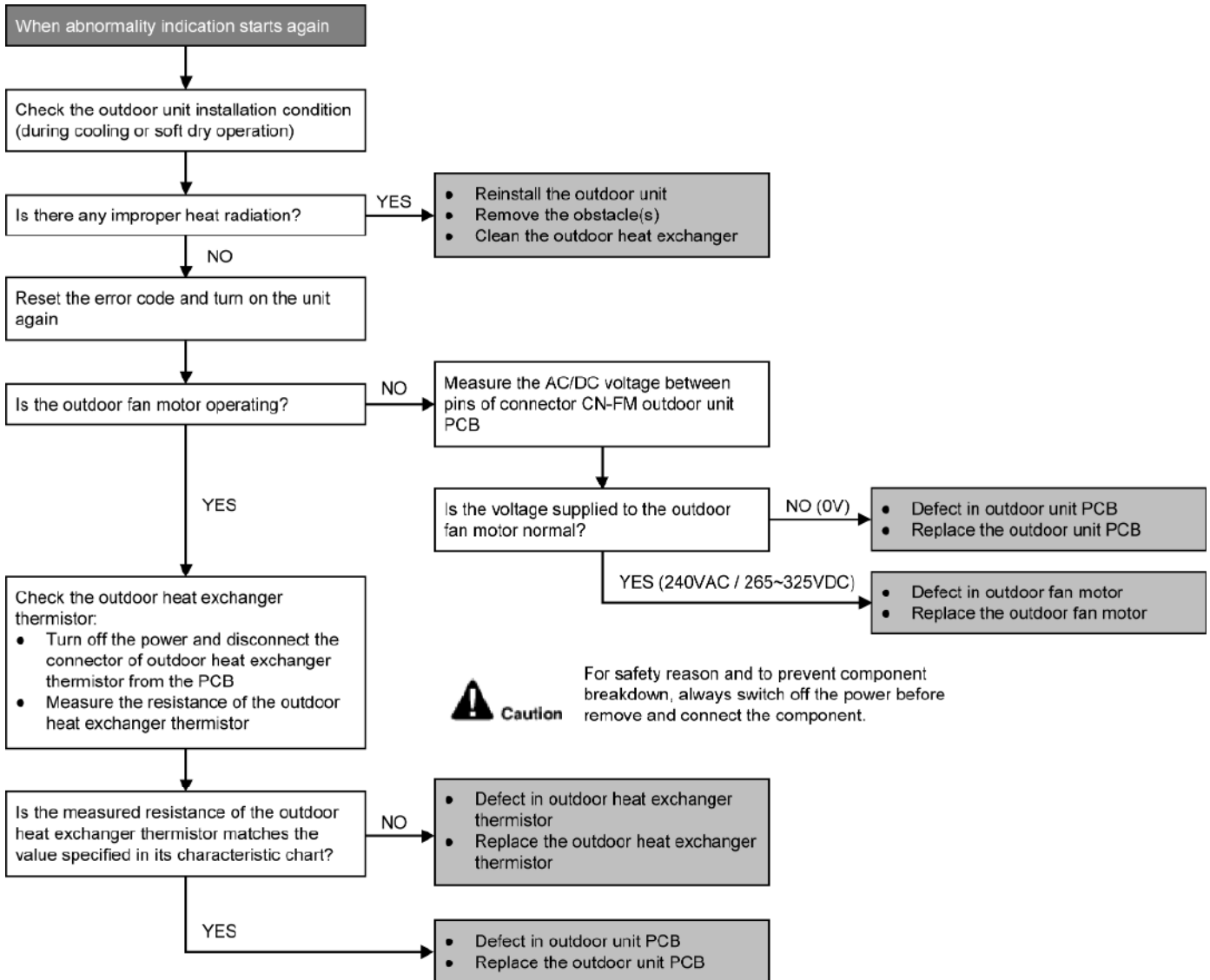

## 17.4.27 F96 (IPM Overheating)

### Malfunction Decision Conditions

- During operating of cooling and heating, when IPM temperature data (100°C) is detected by the IPM temperature sensor.

#### *Multi Models only*

- Compressor Overheating: During operation of cooling and heating, when the compressor OL is activated.
- Heat Sink Overheating: During operation of cooling and heating, when heat sink temperature data (90°C) is detected by the heat sink temperature sensor.

### Malfunction Caused

- IPM overheats due to short circuit of hot discharge air flow.
- IPM overheats due to defective of outdoor fan motor.
- IPM overheats due to defective of internal circuitry of IPM.
- IPM overheats due to defective IPM temperature sensor.

#### *Multi Models Only*

- Compressor OL connector poor contact.
- Compressor OL faulty.

### Troubleshooting

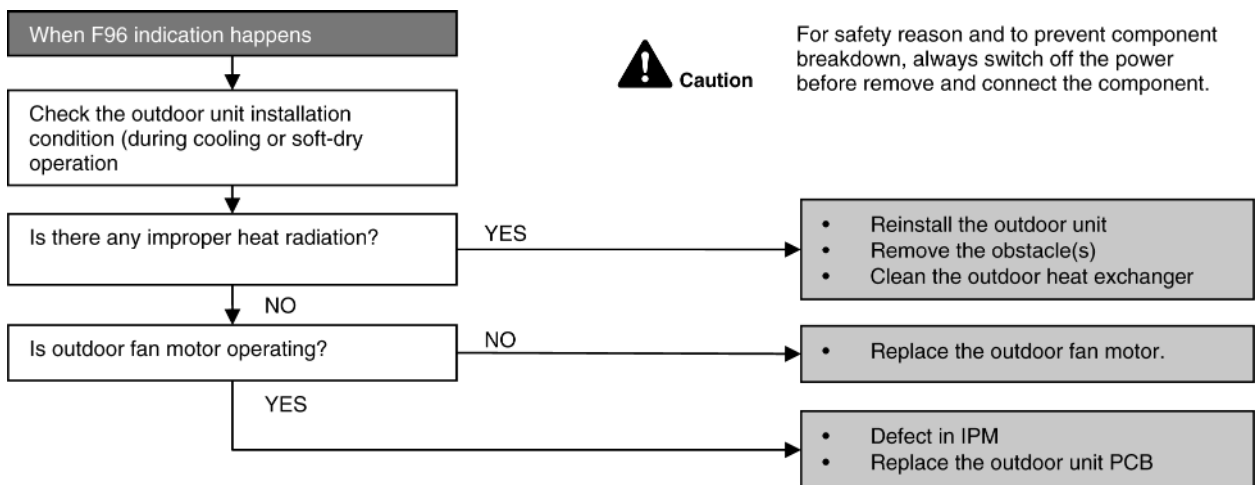

## 17.4.28 F97 (Compressor Overheating)

### Malfunction Decision Conditions

- During operation of cooling and heating, when compressor tank temperature data (112°C) is detected by the compressor tank temperature sensor.

### Malfunction Caused

- Faulty compressor tank temperature sensor
- 2/3 way valve closed
- Refrigerant shortage (refrigerant leakage)
- Faulty outdoor unit PCB
- Faulty compressor

### Troubleshooting

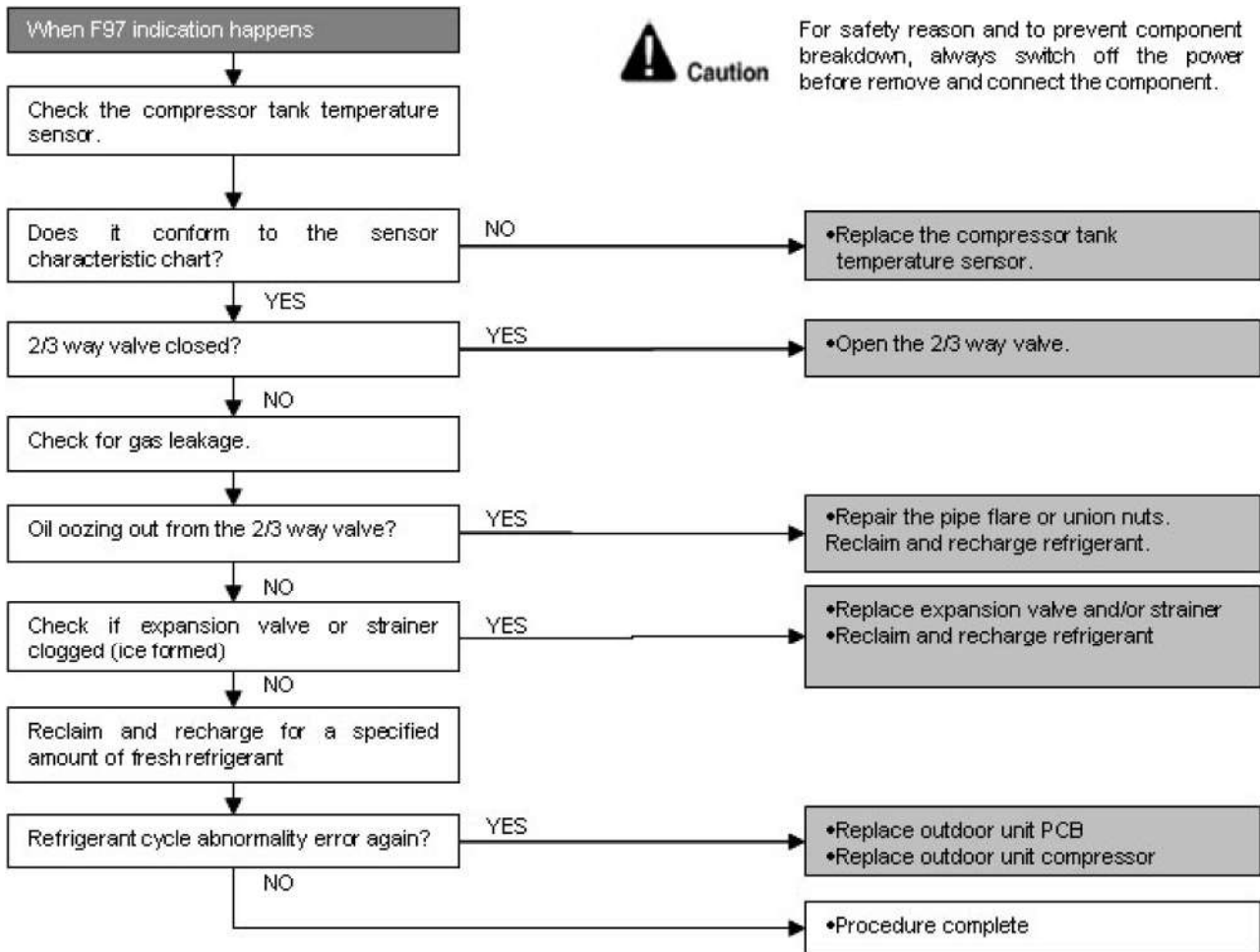

## 17.4.29 F98 (Input Over Current Detection)

### Malfunction Decision Conditions

- During operation of cooling and heating, when an input over-current (X value in Total Running Current Control) is detected by checking the input current value being detected by current transformer (CT) with the compressor running.

### Malfunction Caused

- Excessive refrigerant.
- Faulty outdoor unit PCB.

### Troubleshooting

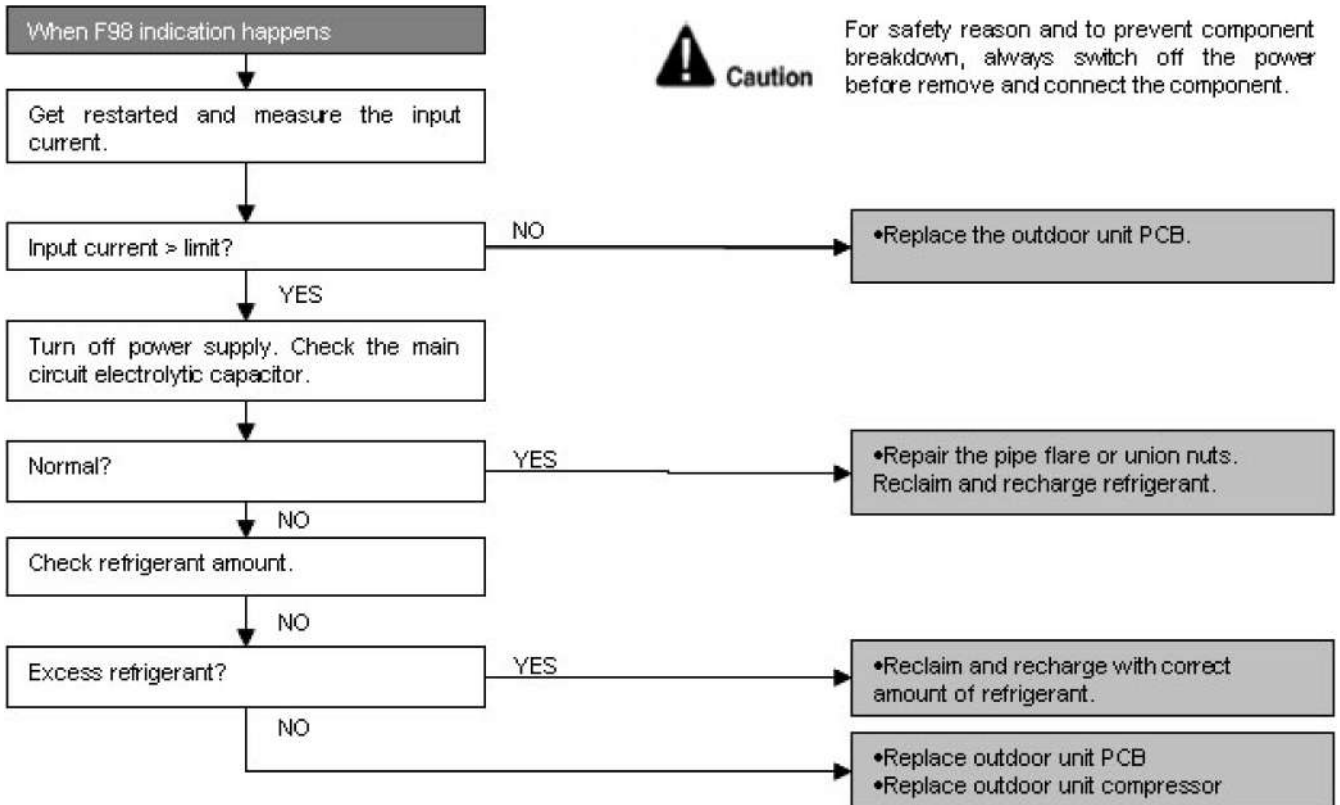

## 17.4.30 F99 (DC Peak Detection)

### Malfunction Decision Conditions

During startup and operation of cooling and heating, when inverter DC peak data is received by the outdoor internal DC Peak sensing circuitry.

### Malfunction Caused

- DC current peak due to compressor failure.
- DC current peak due to defective power transistor(s).
- DC current peak due to defective outdoor unit PCB.
- DC current peak due to short circuit.

### Troubleshooting

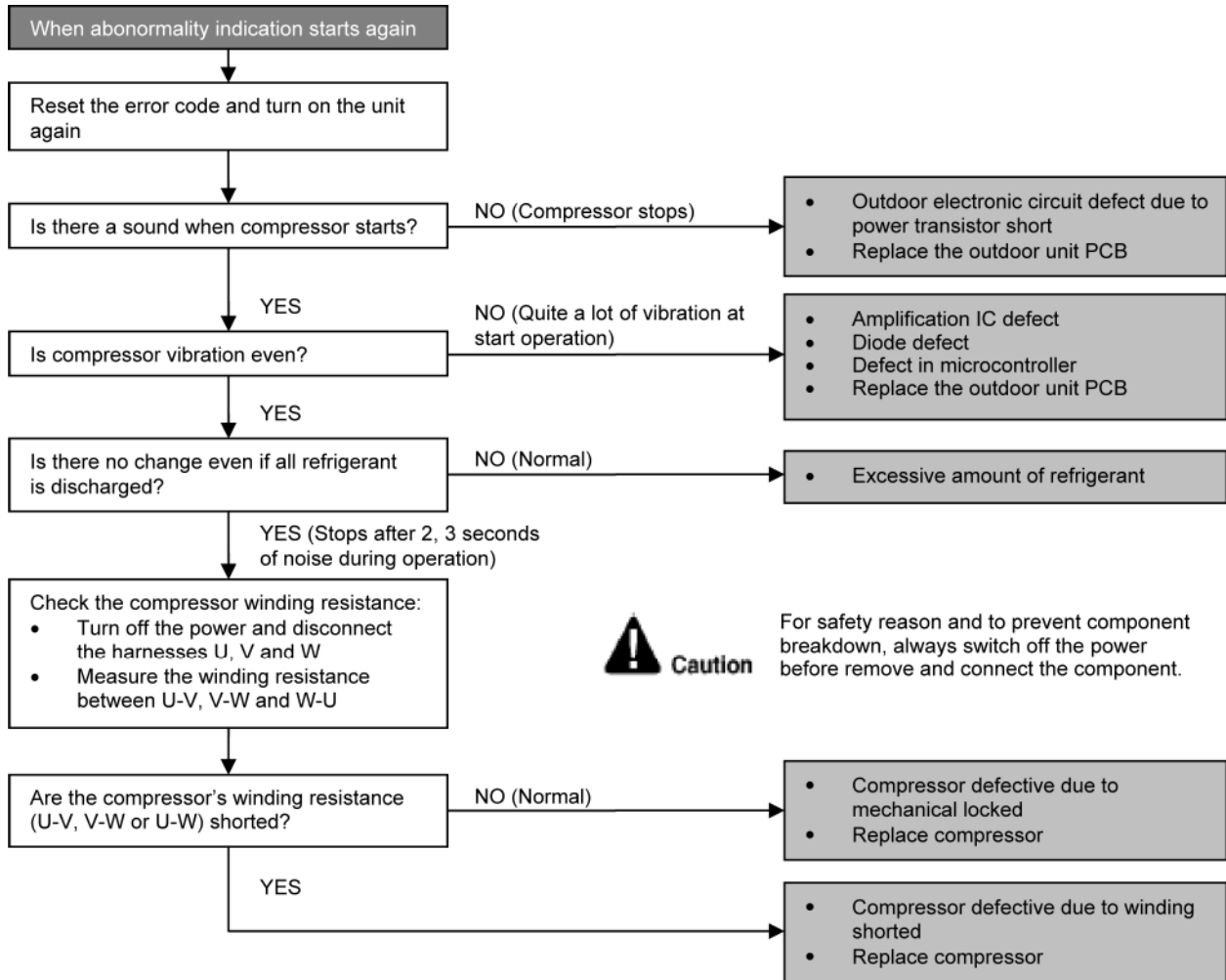

# 18. Disassembly and Assembly Instructions



**WARNING**

High Voltage is generated in the electrical parts area by the capacitor. Ensure that the capacitor has discharged sufficiently before proceeding with repair work. Failure to heed this caution may result in electric shocks.

## 18.1 CS-Z25YKEA CS-Z35YKEA CS-Z42YKEA

### 18.1.1 Indoor Electronic Controllers, Cross Flow Fan and Indoor Fan Motor Removal Procedures

#### 18.1.1.1 To Remove Front Grille

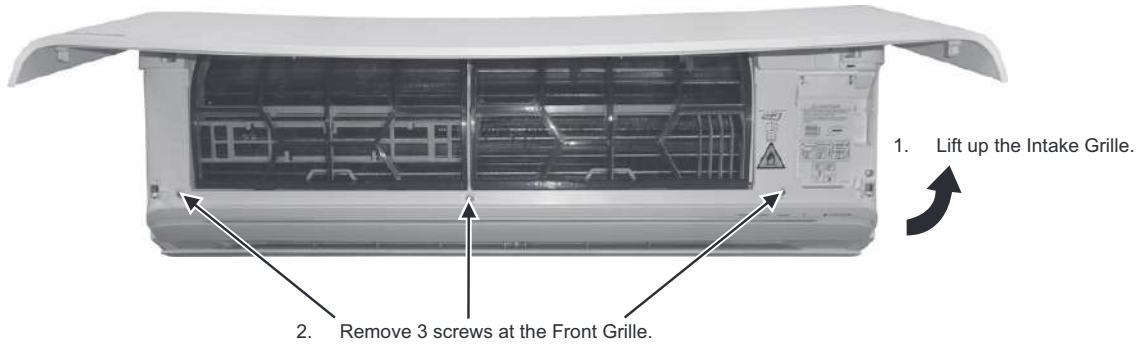

Figure 1

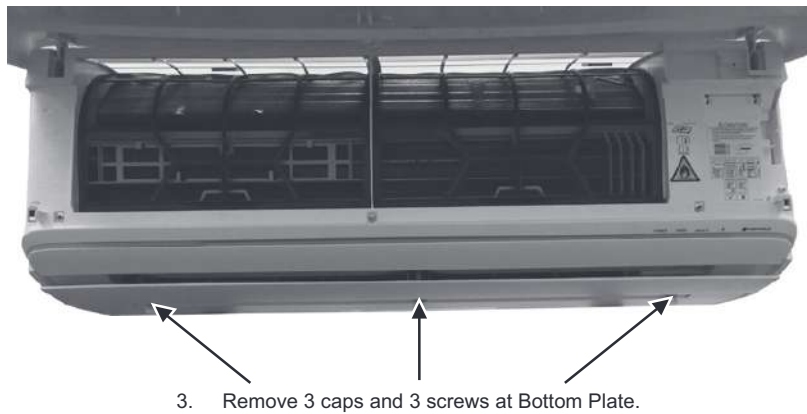

Figure 2



Figure 3

5. Open the hooks on top of the Front Grille.



Figure 4

6. Remove the Front Grille.



Figure 5

### 18.1.1.2 To Remove Electronic Controller



1. Remove the right side front cover first, then remove the second front cover.

Figure 6

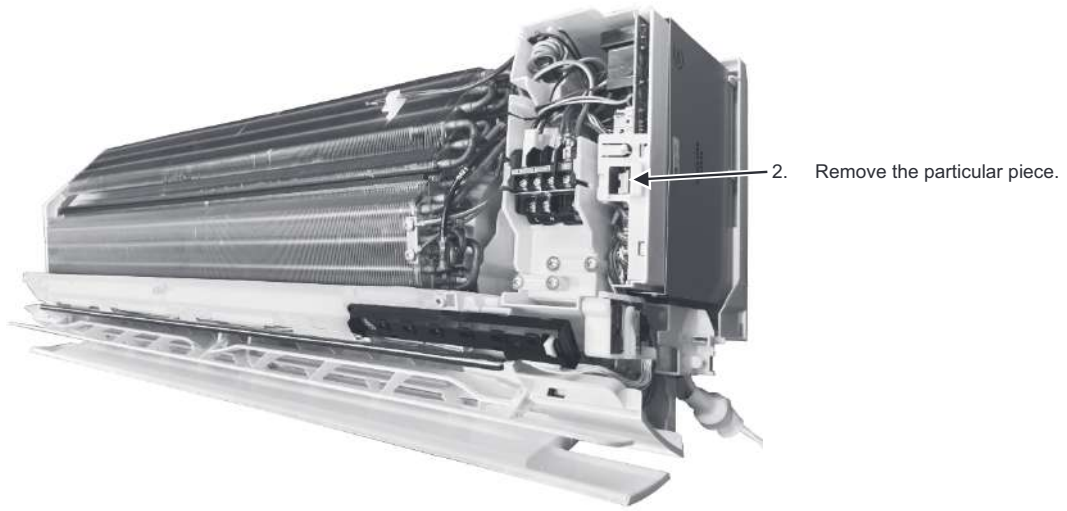

**Figure 7**

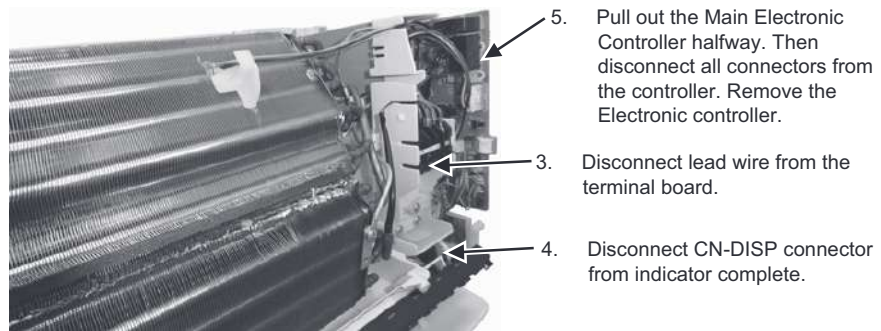

**Figure 8**

### 18.1.1.3 To Remove Discharge Grille

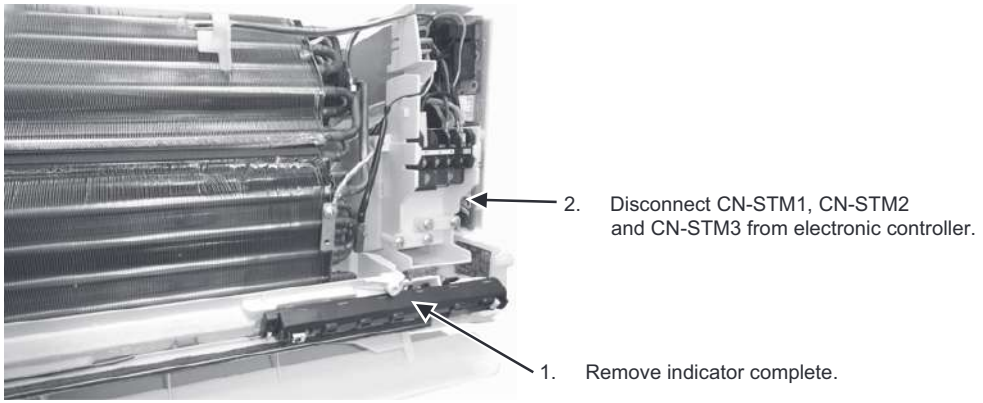

Figure 9

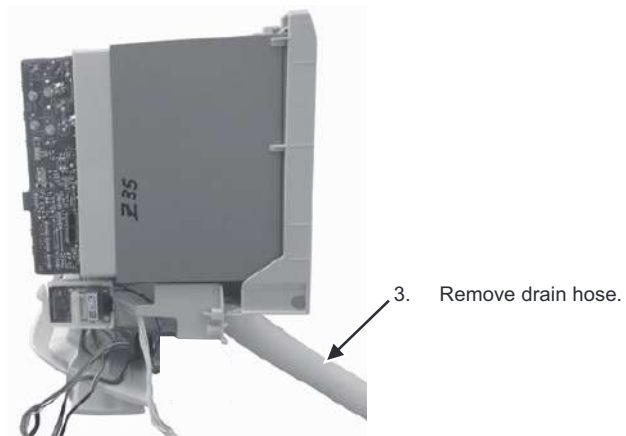

Figure 10

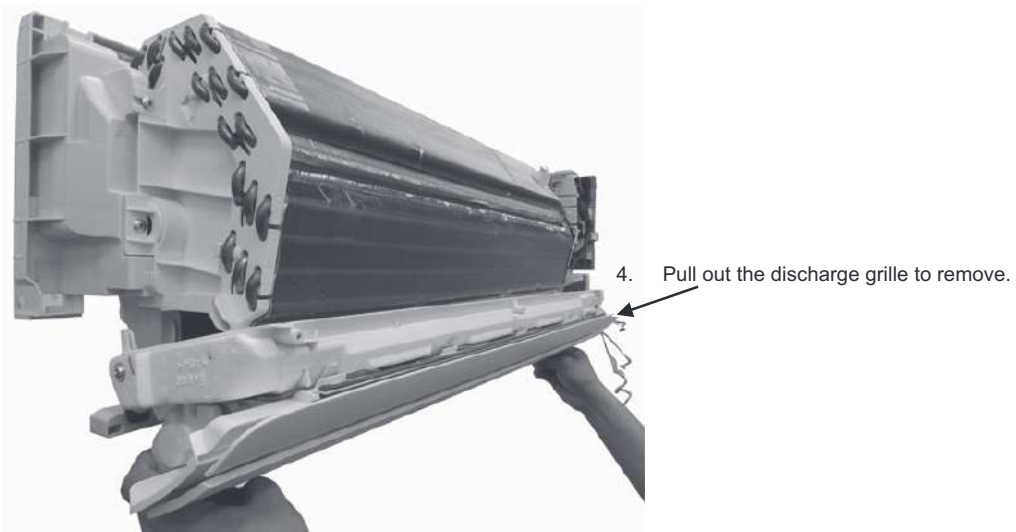

Figure 11

#### 18.1.1.4 To Remove Cross Flow Fan

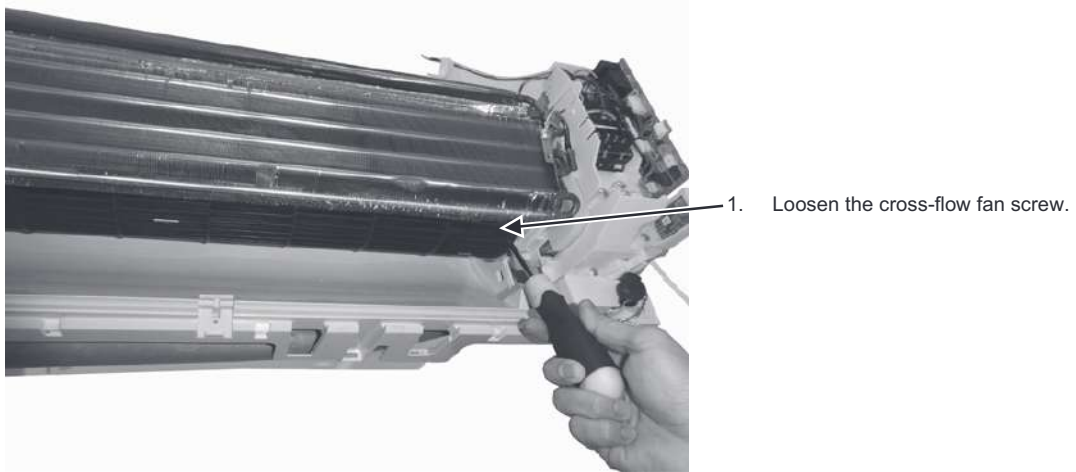

Figure 12

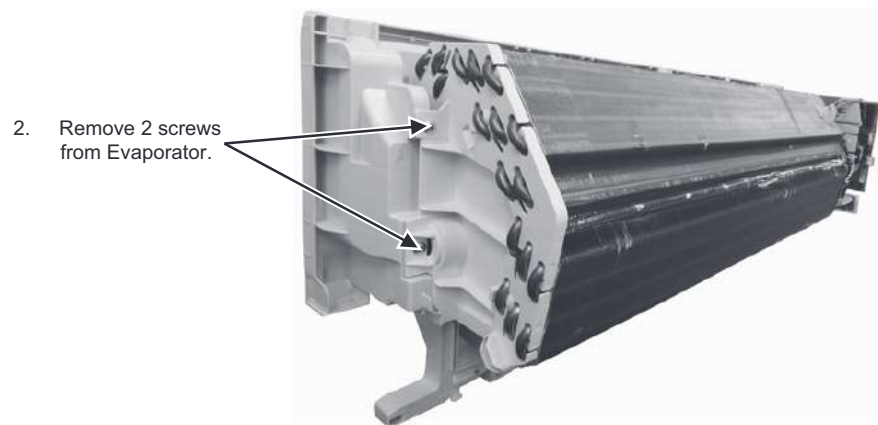

Figure 13

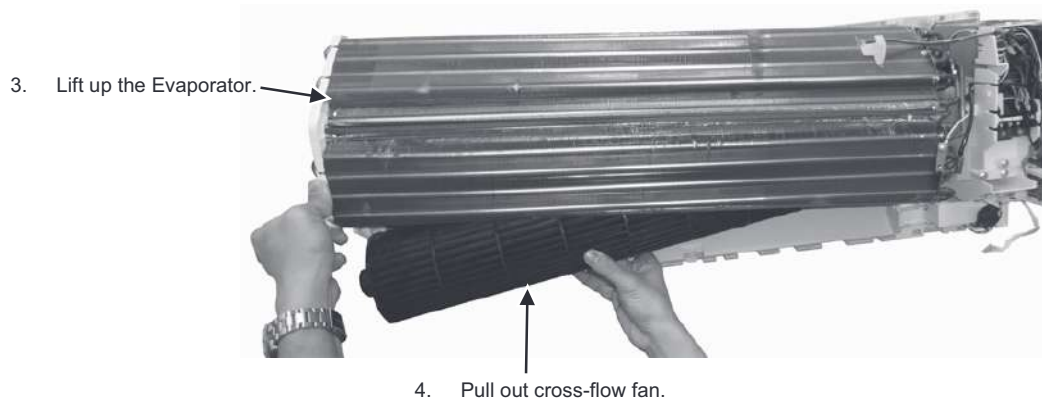

Figure 14

### 18.1.1.5 To Remove Fan Motor

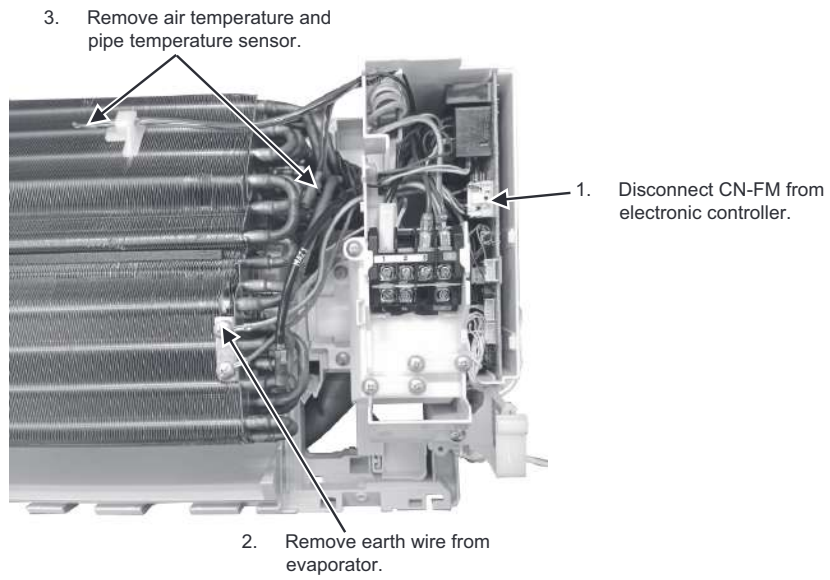

Figure 15

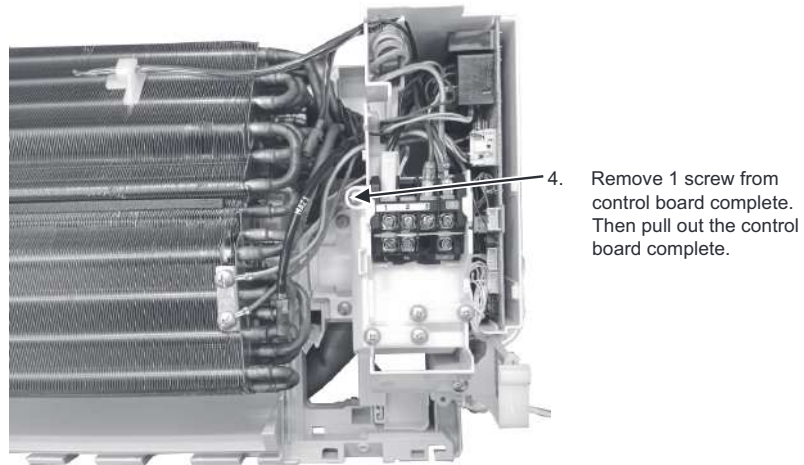

Figure 16

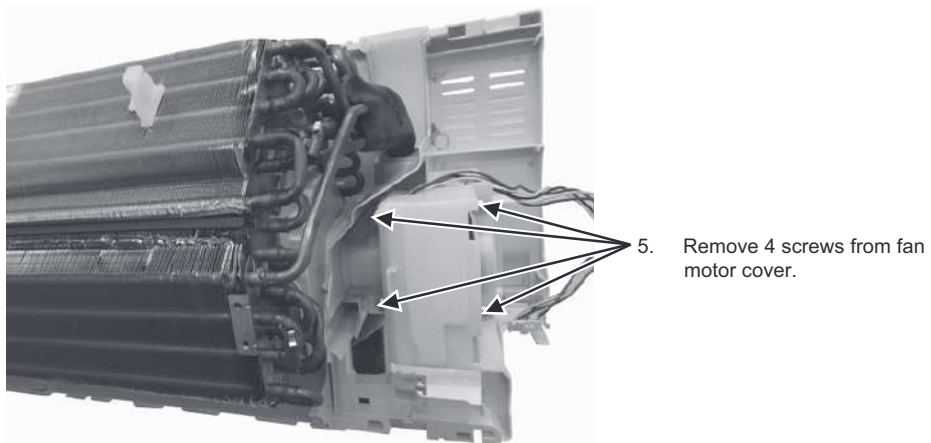

Figure 17

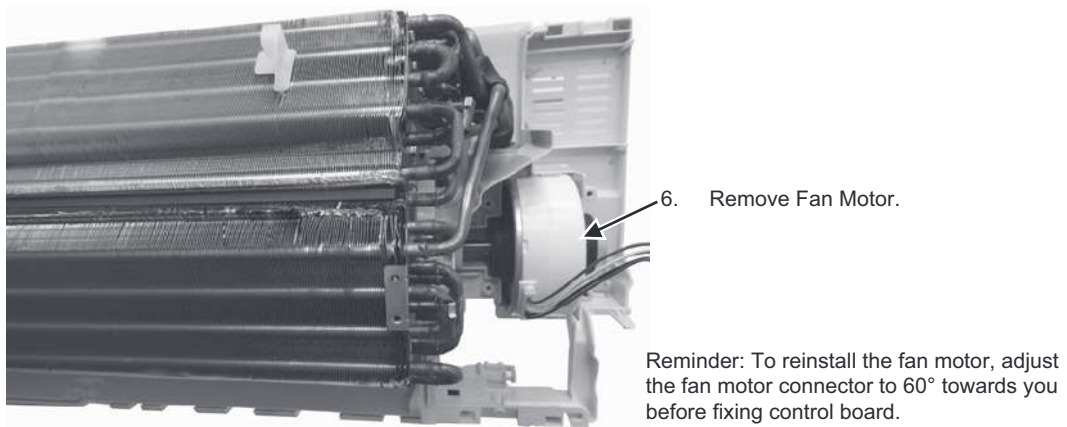
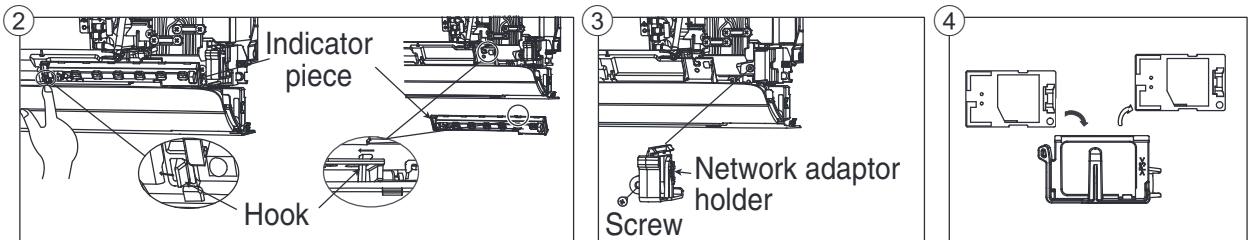

Figure 18

**18.1.1.6 To Replace Wireless LAN Module (Network Adaptor)**

- 1 Remove the front grille (refer how to take out front grille) from the unit.
- 2 Remove the indicator piece by releasing the hook.
- 3 Remove 1 mounting screw, then remove the network adaptor holder.
- 4 After that, network adaptor can be easily replaced.



Reminder: Serviceman or owner must setting again Panasonic Comfort Cloud app after replace Wireless LAN Module.

## 18.2 CS-Z50YKEA CS-Z71YKEA

### 18.2.1 Indoor Electronic Controllers, Cross Flow Fan and Indoor Fan Motor Removal Procedures

#### 18.2.1.1 To Remove Front Grille

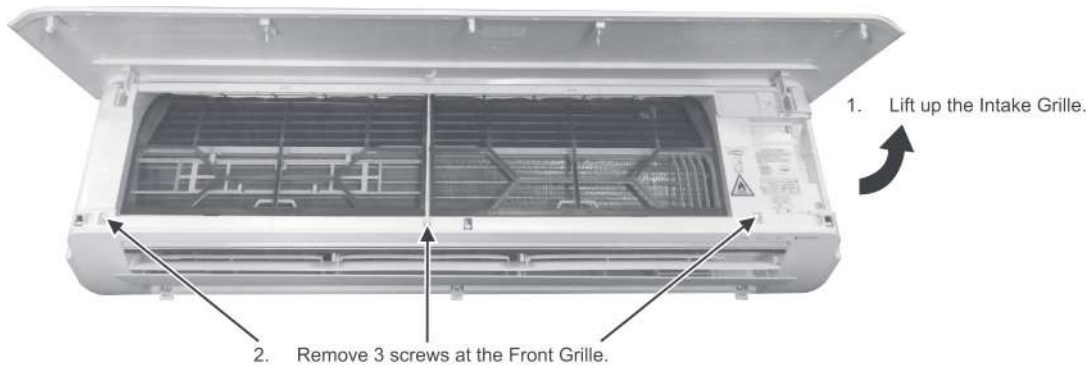

Figure 1

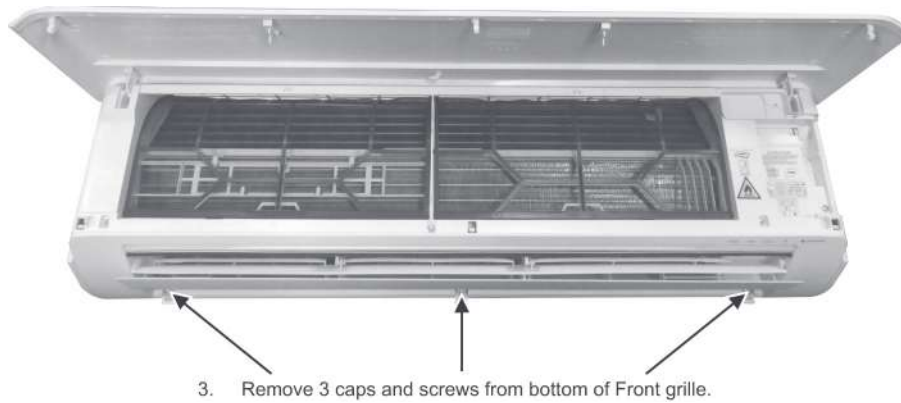

Figure 2

4. Unlock knob from front grille.



Figure 3



Figure 4

### 18.2.1.2 To Remove Electronic Controller



Figure 5

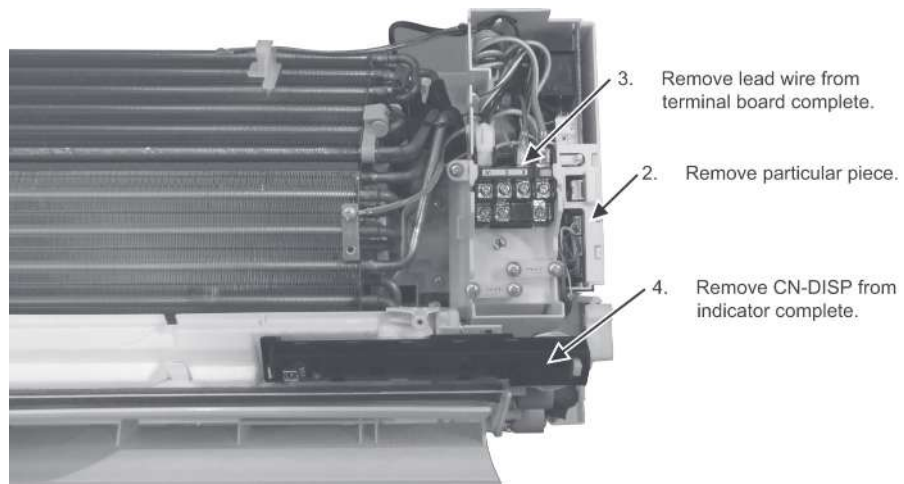
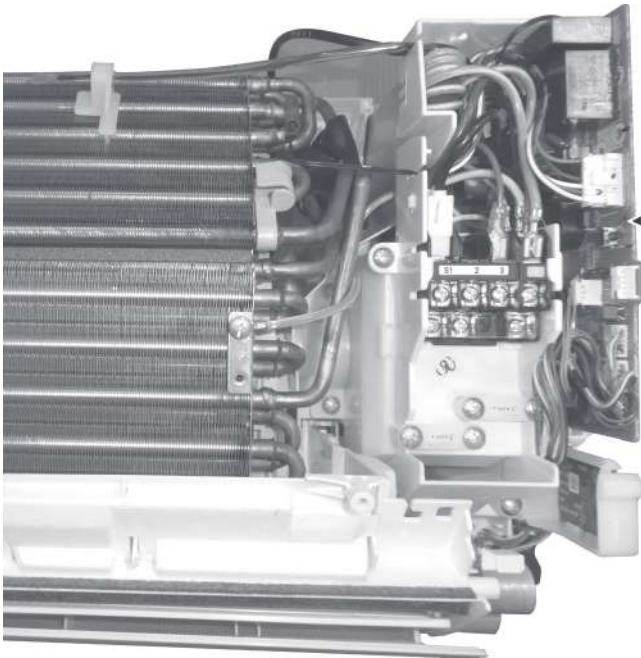

Figure 6



5. Pull PCB half way then remove all connectors, CN-WHT from PCB. Then Remove main electronic controller. Then remove PCB.

Figure 7

**18.2.1.3 To Remove Discharge Grille**

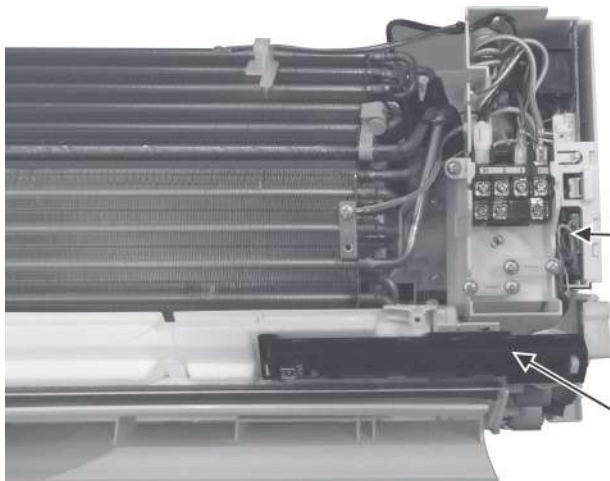

2. Remove CN-STM 1, 2, 3 from main PCB.  
1. Remove indicator complete.

Figure 8



3. Remove drain hose.

Figure 9

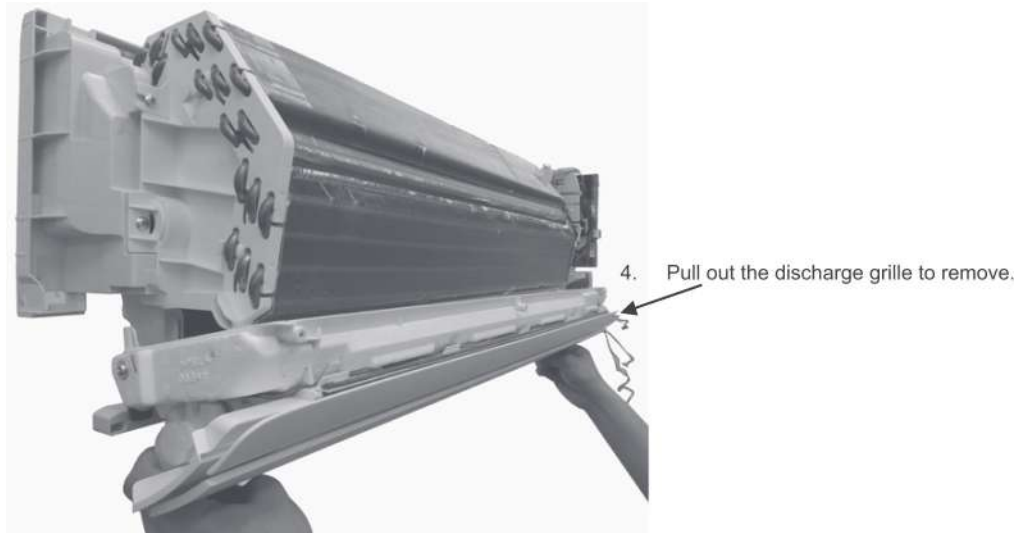

Figure 10

#### 18.2.1.4 To Remove Cross Flow Fan

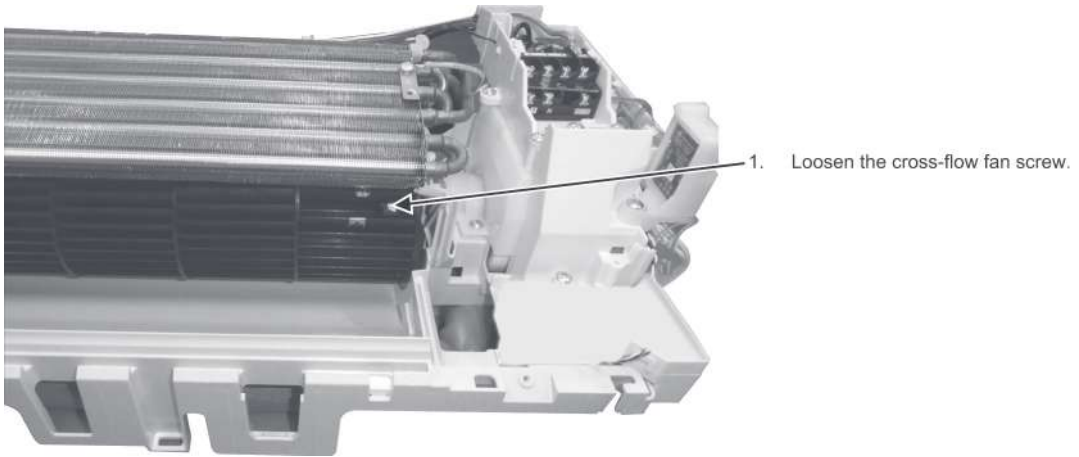

Figure 11

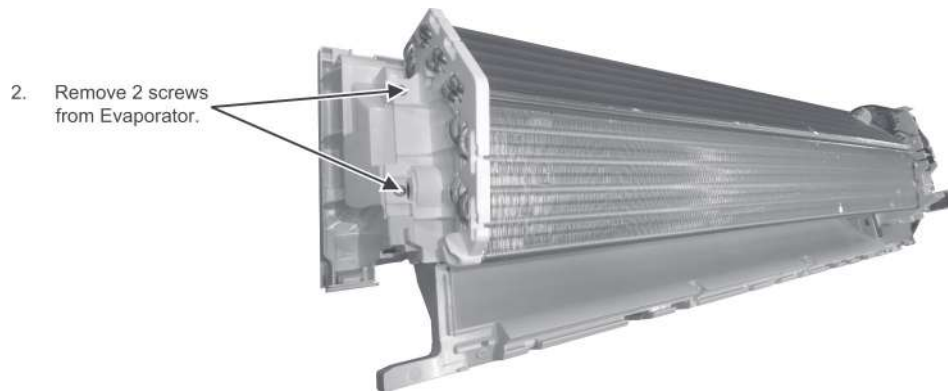

Figure 12

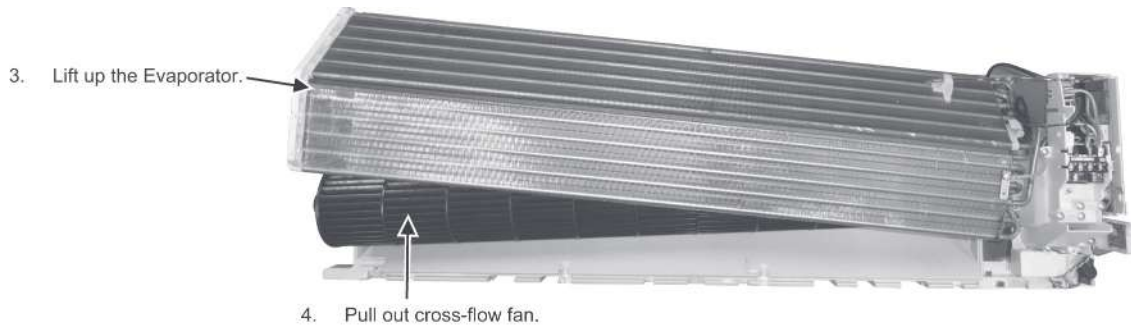

Figure 13

### 18.2.1.5 To Remove Fan Motor

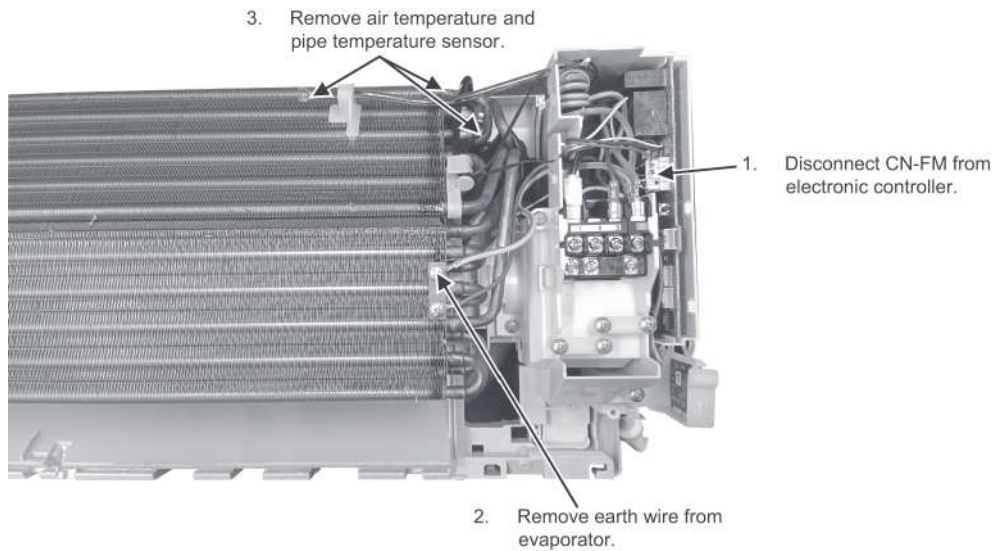

Figure 14

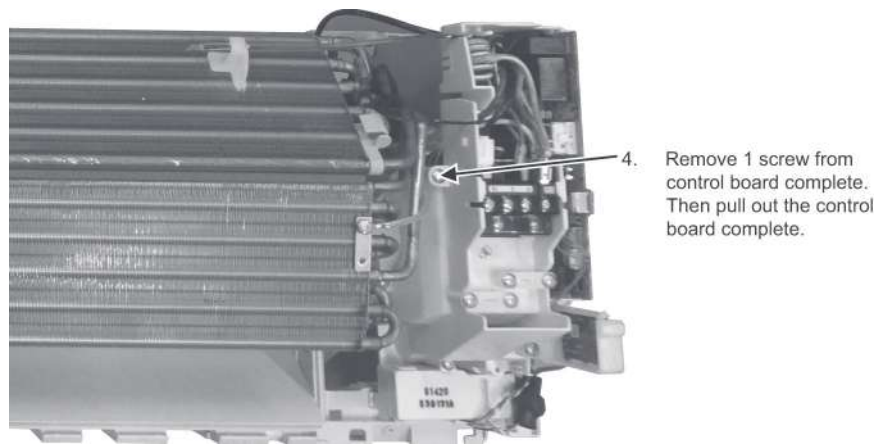

Figure 15

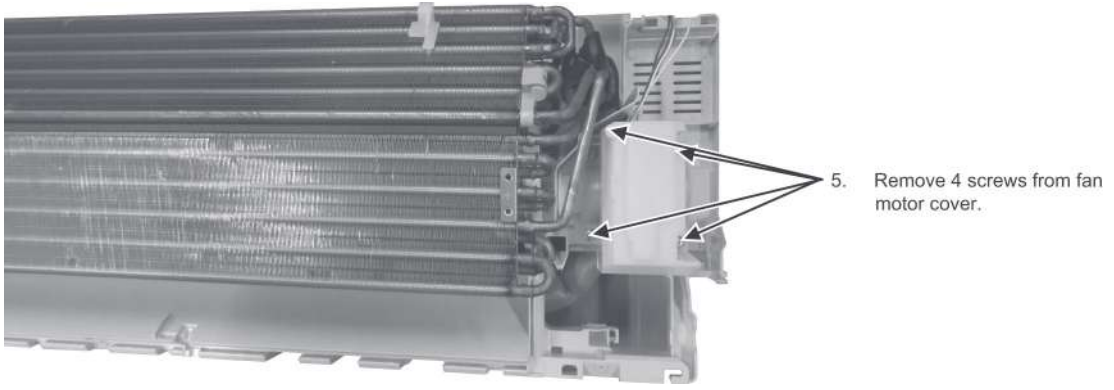

Figure 16

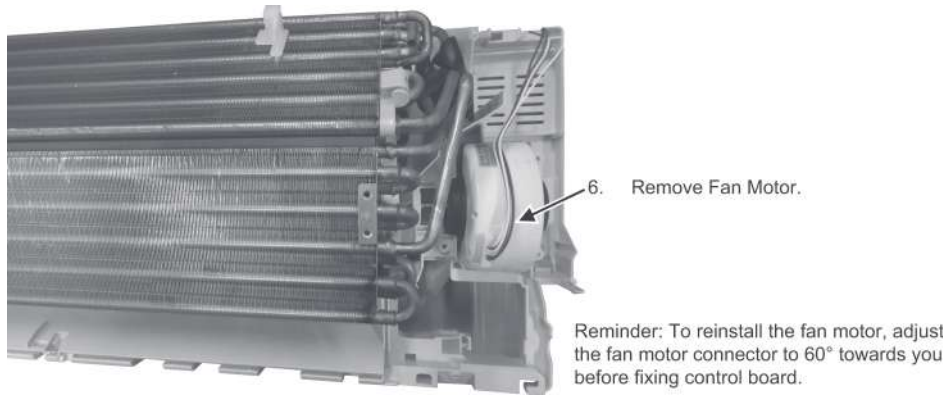

Figure 17

**18.2.1.6 To Remove NanoeX**

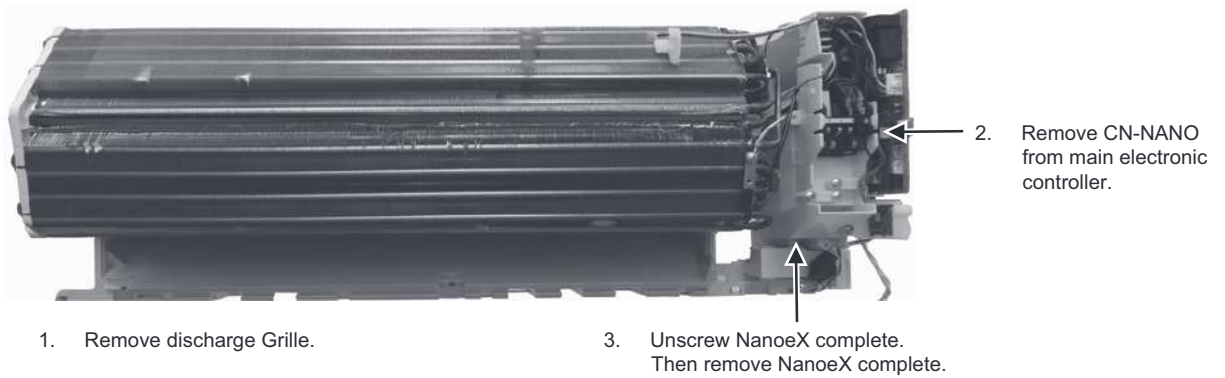
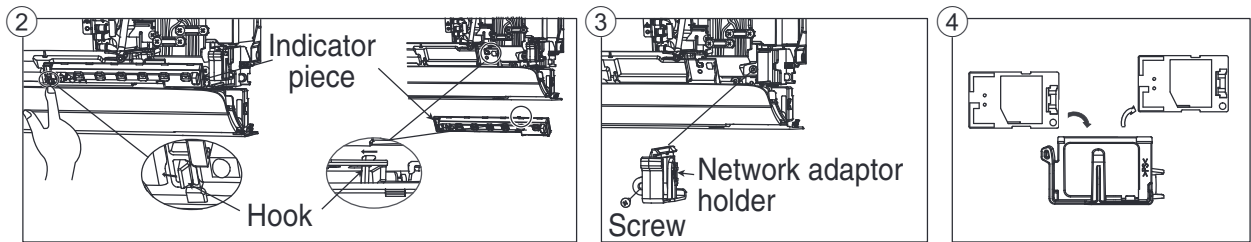

Figure 18

### 18.2.1.7 To Replace Wireless LAN Module (Network Adapter)

- 1 Remove the front grille (refer how to take out front grille) from the unit.
- 2 Remove the indicator piece by releasing the hook.
- 3 Remove 1 mounting screw, then remove the network adaptor holder.
- 4 After that, network adaptor can be easily replaced.



Reminder: Serviceman or owner must setting again Panasonic Comfort Cloud app after replace Wireless LAN Module.

### 18.3 To setup Wireless LAN Module and Panasonic Comfort Cloud

Note: Refer to Wireless LAN Module Setup Instructions [ACXF55-33580]

## 18.4 Outdoor Electronic Controller Removal Procedure

### 18.4.1 CU-Z25YKEA CU-Z35YKEA CU-Z42YKEA

⚠ Caution! When handling electronic controller, be careful of electrostatic discharge.

- 1 Remove the 5 screws of the Top Panel.

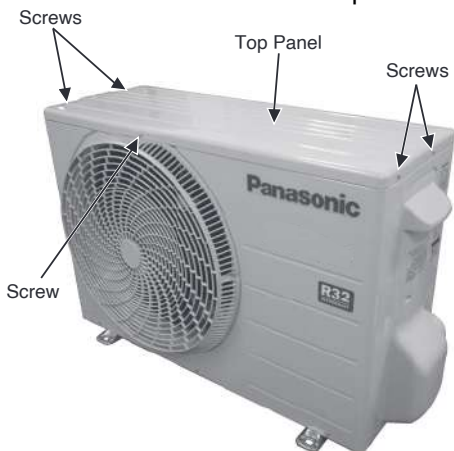

Fig. 1

- 2 Remove the 6 screws of the Front Panel.

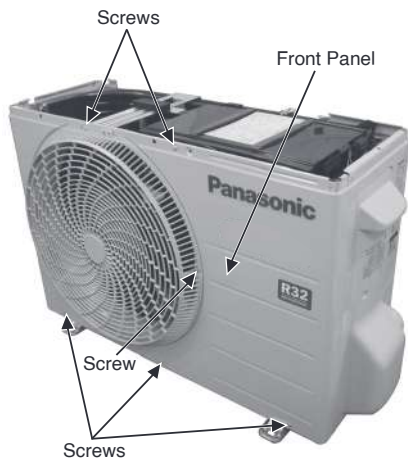

Fig. 2

- 3 Remove the screw of the Terminal Board Cover.
- 4 Remove the Top Cover of the Control Board by 4 hooks.

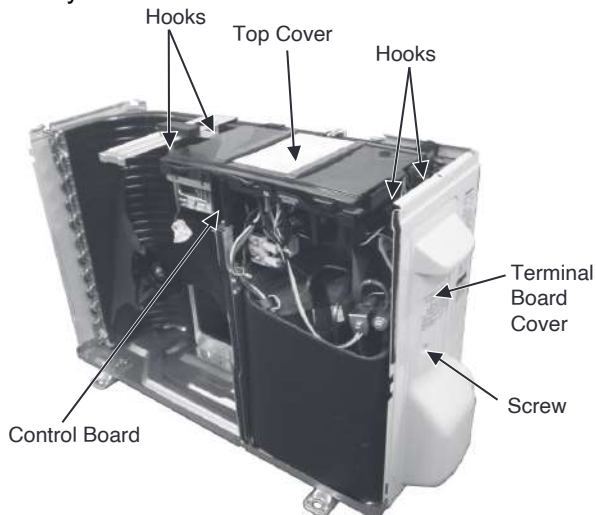

Fig. 3

- 5 Remove the Control Board as follows:

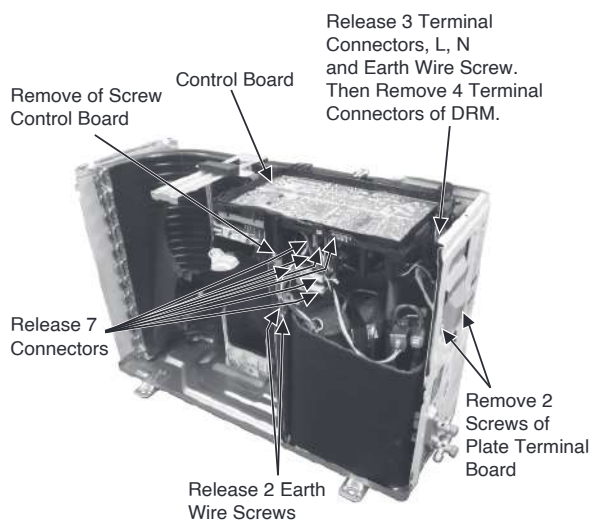

Fig. 4

Remove the Terminal Cover and 3 Terminal Compressor

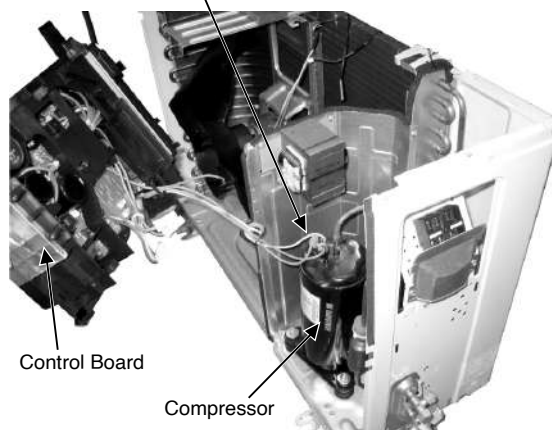

Fig. 5

Electronic Controller Control Board

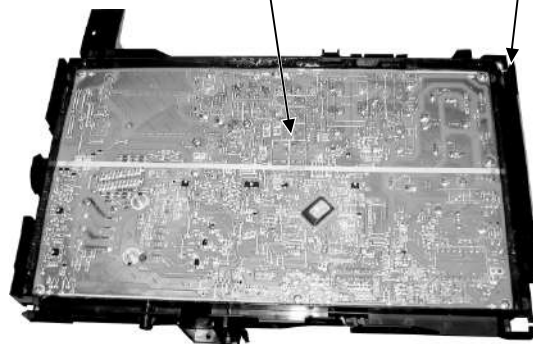

Fig. 6

## 18.4.2 CU-Z50YKEA CU-Z71YKEA

⚠ Caution! When handling electronic controller, be careful of electrostatic discharge.

- 1 Remove the 5 screws of the Top Panel.

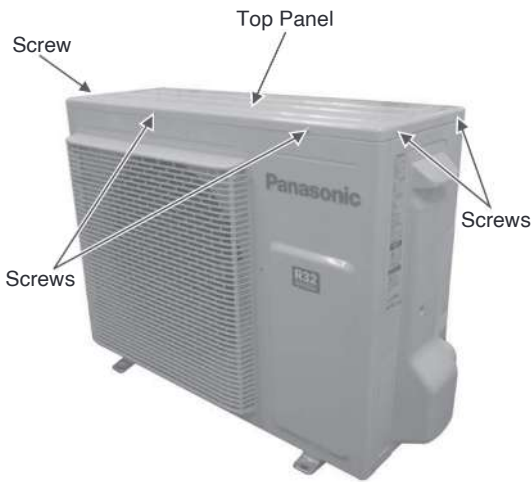

Fig. 1

- 5 Remove 2 screws for the plate of Terminal Board Cover.

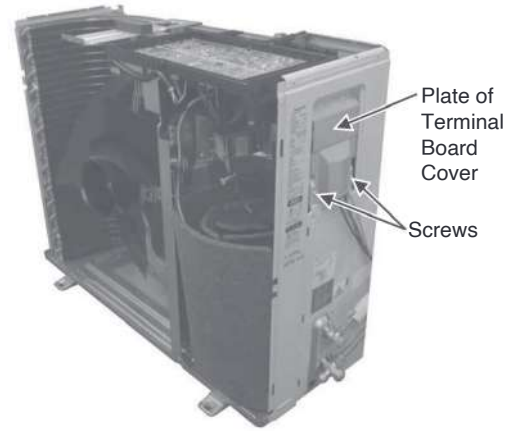

Fig. 4

- 2 Remove the 8 screws of the Front Panel.

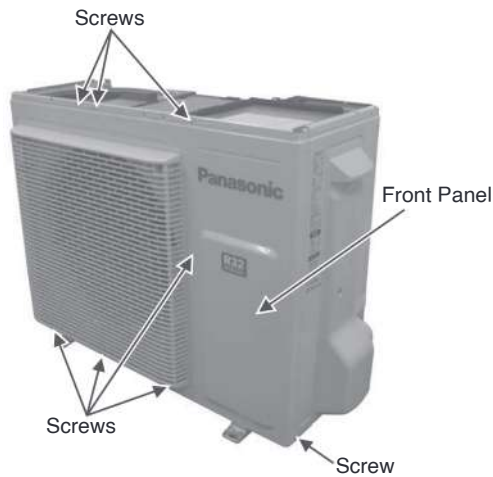

Fig. 2

- 6 Remove the Control Board.

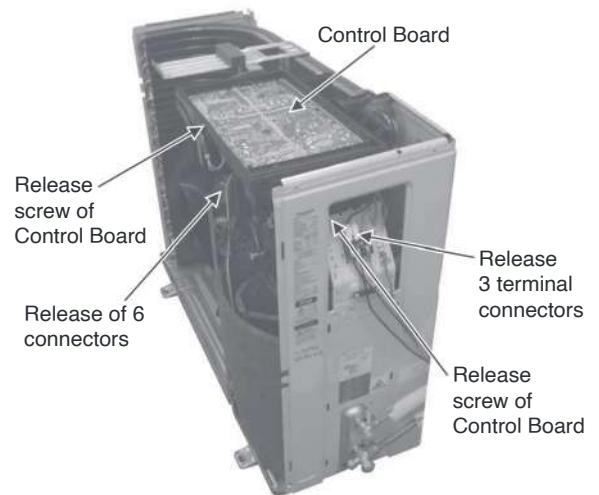

Fig. 5

- 3 Remove the screw of the Terminal Board Cover.

- 4 Remove the Top Cover of the Electronic Controller by 4 hooks.

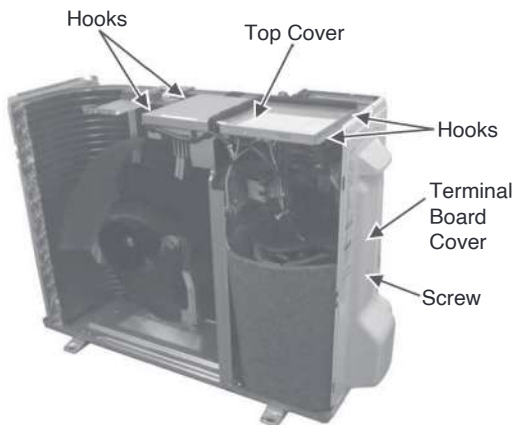

Fig. 3

- 7 Remove the 4 screws of the Electronic Controller.

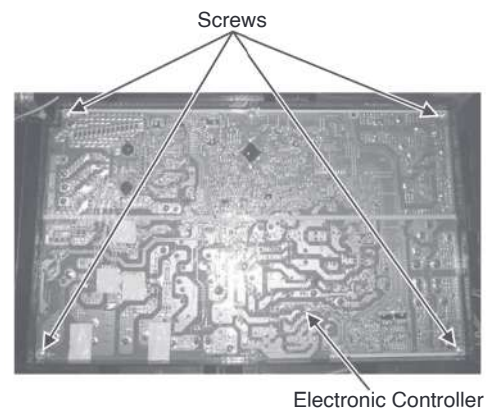

Fig. 6

# 19. Technical Data

Technical data provided are based on the air conditioner running under free frequency.

## 19.1 Cool Mode Performance Data

Unit setting: Standard piping length, Hi Fan, Cool mode at 16°C Voltage: 230V

### 19.1.1 CS-Z25YKEA CU-Z25YKEA

Indoor (°C)		Outdoor DB (°C)																	
DB	WB	-25			-20			-10			-7			0			5		
		TC	SHC	IP	TC	SHC	IP	TC	SHC	IP	TC	SHC	IP	TC	SHC	IP	TC	SHC	IP
27	19.0	2776	2412	389	2862	2450	381	2816	2724	411	3044	2626	371	3020	2667	398	2851	2627	357
	22.0	3106	1882	387	3146	1867	376	3351	1896	344	3108	1940	412	3327	2060	337	3186	2015	382
23	15.7	2443	2268	429	2404	1811	435	2716	2599	417	2513	2469	414	2625	2543	381	2590	2519	387
	18.4	2718	1793	377	2728	2277	388	2732	1937	417	2757	1937	408	2843	1966	404	2826	1986	404
20	13.3	2323	2290	387	2293	2265	382	2230	2188	367	2276	2237	434	2321	2276	435	2494	2442	376
	15.8	2432	1717	439	2458	1766	429	2391	1823	448	2511	1882	401	2659	1951	380	2666	1966	391

Indoor (°C)		Outdoor DB (°C)								
DB	WB	16			25			35		
		TC	SHC	IP	TC	SHC	IP	TC	SHC	IP
27	19.0	3041	2712	290	2955	2712	392	2500	2450	510
	22.0	3418	2105	276	3226	1999	390	2857	1870	507
23	15.7	2784	2657	303	2617	2580	400	2351	2309	505
	18.4	3139	2054	296	2885	1994	395	2498	1810	504
20	13.3	2618	2550	310	2391	2349	400	2163	2120	505
	15.8	2880	2050	304	2614	1926	397	2327	1773	505

(Dry bulb value based on 46% humidity)

### 19.1.2 CS-Z35YKEA CU-Z35YKEA

Indoor (°C)		Outdoor DB (°C)																	
DB	WB	-25			-20			-10			-7			0			5		
		TC	SHC	IP	TC	SHC	IP	TC	SHC	IP	TC	SHC	IP	TC	SHC	IP	TC	SHC	IP
27	19.0	3886	3022	649	4007	3069	635	3943	3414	685	4261	3290	618	4228	3342	663	3991	3292	596
	22.0	4348	2359	645	4404	2340	627	4691	2376	573	4351	2431	686	4657	2581	562	4460	2524	636
23	15.7	3420	2842	716	3365	2270	725	3803	3257	696	3518	3190	690	3675	3186	635	3625	3156	646
	18.4	3806	2247	629	3819	2853	646	3825	2427	695	3860	2426	679	3981	2463	673	3956	2488	674
20	13.3	3252	2870	644	3211	2838	636	3122	2964	612	3187	2998	724	3250	2986	724	3492	3138	626
	15.8	3405	2151	732	3441	2213	715	3347	2284	747	3516	2358	668	3722	2445	633	3732	2464	651

Indoor (°C)		Outdoor DB (°C)								
DB	WB	16			25			35		
		TC	SHC	IP	TC	SHC	IP	TC	SHC	IP
27	19.0	4257	3418	484	4137	3398	653	3500	3070	850
	22.0	4786	2638	459	4516	2504	650	4000	2343	845
23	15.7	3898	3329	506	3663	3233	667	3291	3030	841
	18.4	4395	2573	493	4038	2498	658	3498	2268	841
20	13.3	3665	3195	517	3347	3066	666	3028	2919	841
	15.8	4032	2569	507	3660	2413	662	3258	2222	842

(Dry bulb value based on 46% humidity)

### 19.1.3 CS-Z42YKEA CU-Z42YKEA

Indoor (°C)		Outdoor DB (°C)																	
DB	WB	-25			-20			-10			-7			0			5		
		TC	SHC	IP	TC	SHC	IP	TC	SHC	IP	TC	SHC	IP	TC	SHC	IP	TC	SHC	IP
27	19.0	4663	3316	839	4809	3368	822	4731	3746	887	5114	3610	800	5073	3667	858	4789	3612	771
	22.0	5218	2588	835	5285	2567	812	5629	2607	742	5222	2668	888	5589	2832	728	5352	2770	823
23	15.7	4104	3118	926	4038	2490	939	4564	3574	900	4222	3500	893	4410	3496	821	4350	3463	836
	18.4	4567	2466	813	4583	3130	837	4590	2663	900	4632	2662	879	4777	2703	871	4747	2730	872
20	13.3	3903	3149	834	3853	3114	823	3747	3252	791	3824	3289	937	3900	3276	937	4190	3444	810
	15.8	4086	2360	947	4129	2428	925	4017	2506	966	4219	2587	865	4467	2682	819	4478	2703	843

Indoor (°C)		Outdoor DB (°C)								
DB	WB	16			25			35		
		TC	SHC	IP	TC	SHC	IP	TC	SHC	IP
27	19.0	5108	3750	626	4964	3729	845	4200	3368	1100
	22.0	5743	2894	594	5419	2748	841	4800	2571	1094
23	15.7	4678	3653	654	4396	3547	863	3950	3324	1089
	18.4	5274	2824	638	4846	2741	851	4197	2488	1088
20	13.3	4398	3505	669	4016	3364	862	3633	3203	1088
	15.8	4838	2819	656	4391	2647	857	3910	2438	1089

(Dry bulb value based on 46% humidity)

### 19.1.4 CS-Z50YKEA CU-Z50YKEA

Indoor (°C)		Outdoor DB (°C)																	
DB	WB	-25			-20			-10			-7			0			5		
		TC	SHC	IP	TC	SHC	IP	TC	SHC	IP	TC	SHC	IP	TC	SHC	IP	TC	SHC	IP
27	19.0	5430	4387	1026	5587	4452	1053	5497	4469	1082	5620	4639	1072	5757	4473	935	5632	4343	1036
	22.0	5895	3117	1081	6202	3448	960	6225	3272	954	6271	3273	981	6233	3298	967	6104	3198	1093
23	15.7	4304	3556	1155	5178	4413	1011	5142	4007	980	5164	4027	995	5094	4005	959	5202	4067	1008
	18.4	5298	3072	1180	5345	3409	1103	5567	3255	925	5587	3257	1061	5486	3224	1015	5641	3271	1043
20	13.3	3798	3722	526	4525	4162	870	3989	3498	807	3957	3531	945	3825	3571	636	3430	3188	588
	15.8	4281	2690	559	5093	3402	1041	5005	3125	1061	4238	2759	926	4472	2841	765	3952	2657	621

Indoor (°C)		Outdoor DB (°C)								
DB	WB	16			25			35		
		TC	SHC	IP	TC	SHC	IP	TC	SHC	IP
27	19.0	5986	4583	810	5610	5004	1062	5000	4149	1360
	22.0	6582	3404	774	6157	3248	1077	5501	3014	1377
23	15.7	5208	4055	836	5029	3938	1072	4542	3835	1360
	18.4	5722	3246	814	5495	3234	1091	4949	3003	1373
20	13.3	5074	4973	855	4632	3841	1076	4219	3658	1357
	15.8	5326	3228	833	5004	3134	1099	4498	2917	1373

(Dry bulb value based on 46% humidity)

### 19.1.5 CS-Z71YKEA CU-Z71YKEA

Indoor (°C)		Outdoor DB (°C)																	
DB	WB	-25			-20			-10			-7			0			5		
		TC	SHC	IP	TC	SHC	IP	TC	SHC	IP	TC	SHC	IP	TC	SHC	IP	TC	SHC	IP
27	19.0	7577	5570	1513	8370	5789	1314	8643	5917	1199	8861	6013	1219	8660	5951	1354	8257	5784	1566
	22.0	8225	4188	1594	9086	4626	1385	9496	4742	1298	9887	4970	1115	9377	4778	1400	8950	4516	1651
23	15.7	6006	4779	1702	6634	5279	1479	7076	5445	1317	8143	6115	1131	7663	5803	1389	7628	5743	1522
	18.4	7392	4128	1740	8166	4560	1512	8473	4768	1178	8809	4945	1206	8253	4670	1470	8271	4620	1576
20	13.3	5085	4501	419	5059	4532	470	5401	4664	638	6238	5361	1075	5755	5173	921	5029	4502	888
	15.8	5973	3615	824	6598	3993	716	7099	4325	1287	6682	4190	1052	6728	4115	1107	5794	3752	938

Indoor (°C)		Outdoor DB (°C)								
DB	WB	16			25			35		
		TC	SHC	IP	TC	SHC	IP	TC	SHC	IP
27	19.0	8256	5725	1440	7658	5541	1806	7100	5351	2240
	22.0	9078	4522	1376	8405	4269	1831	7811	4122	2268
23	15.7	7183	5386	1488	6865	5177	1823	6450	5245	2240
	18.4	7892	4312	1449	7501	4251	1856	7027	4107	2261
20	13.3	6998	6858	1521	6323	5050	1830	5992	5003	2235
	15.8	7345	4287	1482	6831	4120	1868	6387	3989	2261

(Dry bulb value based on 46% humidity)

TC - Total Cooling Capacity (W)

SHC - Sensible Heat Capacity (W)

IP - Input Power (W)

## 19.2 Heat Mode Performance Data

Unit setting: Standard piping length, Hi Fan, Heat mode at 30°C Voltage: 230V

### 19.2.1 CS-Z25YKEA CU-Z25YKEA

Indoor (°C)	Outdoor WB (°C)									
DB	-15		-7		2		7		12	
	TC	IP	TC	IP	TC	IP	TC	IP	TC	IP
24	2333	986	2867	1101	3523	1126	3160	696	3405	704
20	2435	960	3050	1100	3620	1120	3400	700	3672	702
16	2488	923	3242	1097	3887	1120	3624	699	3934	697

### 19.2.2 CS-Z35YKEA CU-Z35YKEA

Indoor (°C)	Outdoor WB (°C)									
DB	-15		-7		2		7		12	
	TC	IP	TC	IP	TC	IP	TC	IP	TC	IP
24	2705	1204	3196	1301	4087	1337	3718	894	4006	905
20	2823	1172	3400	1300	4200	1330	4000	900	4320	903
16	2884	1126	3614	1297	4510	1330	4263	899	4628	897

### 19.2.3 CS-Z42YKEA CU-Z42YKEA

Indoor (°C)	Outdoor WB (°C)									
DB	-15		-7		2		7		12	
	TC	IP	TC	IP	TC	IP	TC	IP	TC	IP
24	3033	1404	3863	1601	4797	1659	4926	1342	5307	1357
20	3165	1366	4110	1600	4930	1650	5300	1350	5724	1355
16	3233	1313	4369	1596	5294	1650	5649	1348	6132	1345

### 19.2.4 CS-Z50YKEA CU-Z50YKEA

Indoor (°C)	Outdoor WB (°C)									
DB	-15		-7		2		7		12	
	TC	IP	TC	IP	TC	IP	TC	IP	TC	IP
24	3995	1690	4352	1884	5583	2130	5441	1399	5597	1393
20	4129	1628	4800	1880	5800	2120	5800	1400	6054	1393
16	4461	1541	4964	1876	6226	1800	5713	1392	6475	1399

### 19.2.5 CS-Z71YKEA CU-Z71YKEA

Indoor (°C)	Outdoor WB (°C)									
DB	-15		-7		2		7		12	
	TC	IP	TC	IP	TC	IP	TC	IP	TC	IP
24	5017	2422	5941	2758	6925	2740	7747	2205	8307	2202
20	5297	2295	6310	2600	7390	2740	8200	2210	8899	2202
16	5531	2176	6155	2658	7762	2657	8890	2203	9445	2203

TC - Total Cooling Capacity (W)

SHC - Sensible Heat Capacity (W)

IP - Input Power (W)

## 20. Service Data

Service data provided are based on the air conditioner running under rated frequency during forced cooling / forced heating mode.

### 20.1 Cool Mode Outdoor Air Temperature Characteristic

Condition

- Indoor room temperature: 27°C Dry Bulb/19°C Wet Bulb
- Unit setting: Standard piping length, forced cooling at 16°C, Hi fan
- Compressor frequency: Rated for cooling operation
- Piping length: 5m
- Voltage: 230V

#### 20.1.1 CS-Z25YKEA CU-Z25YKEA

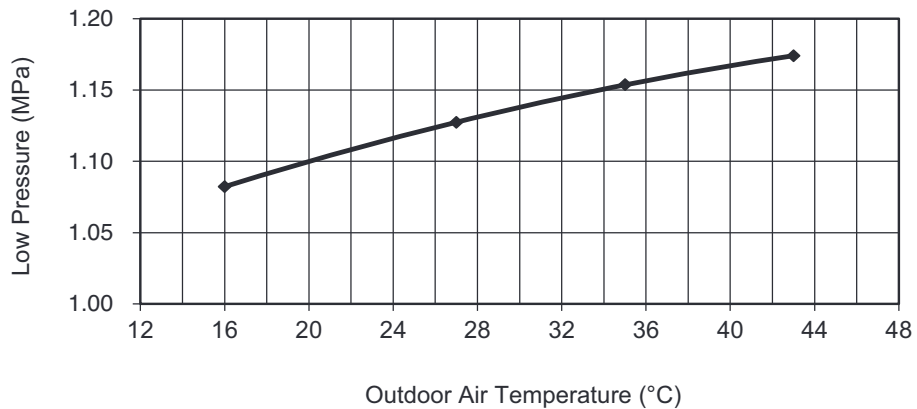
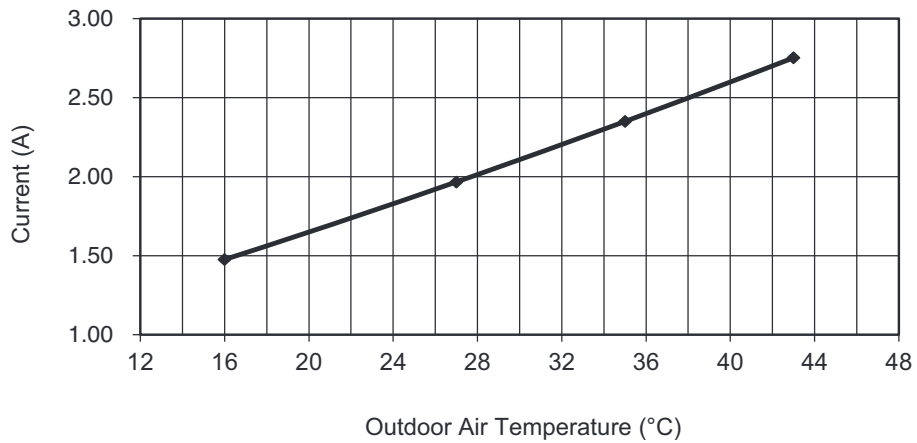
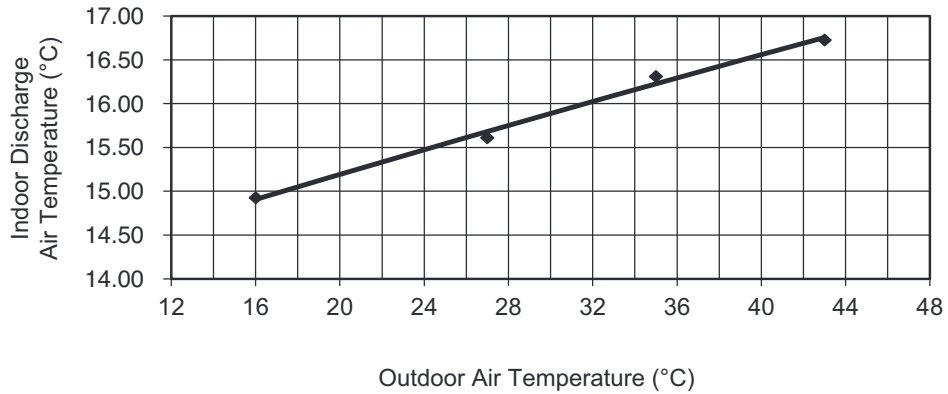

## 20.1.2 CS-Z35YKEA CU-Z35YKEA

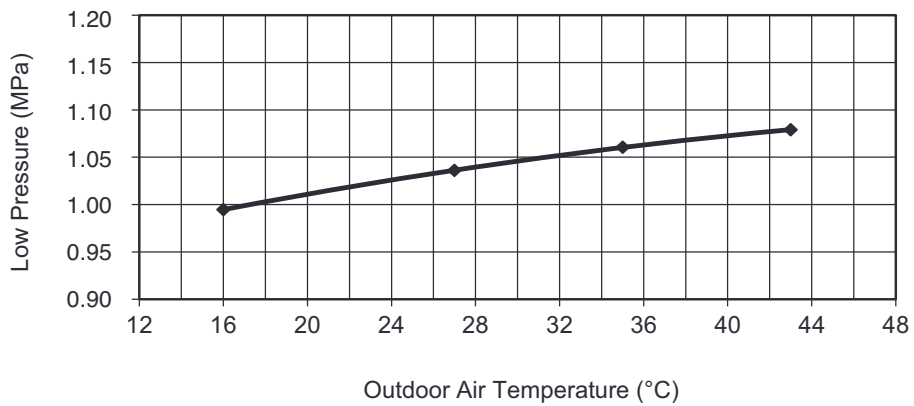
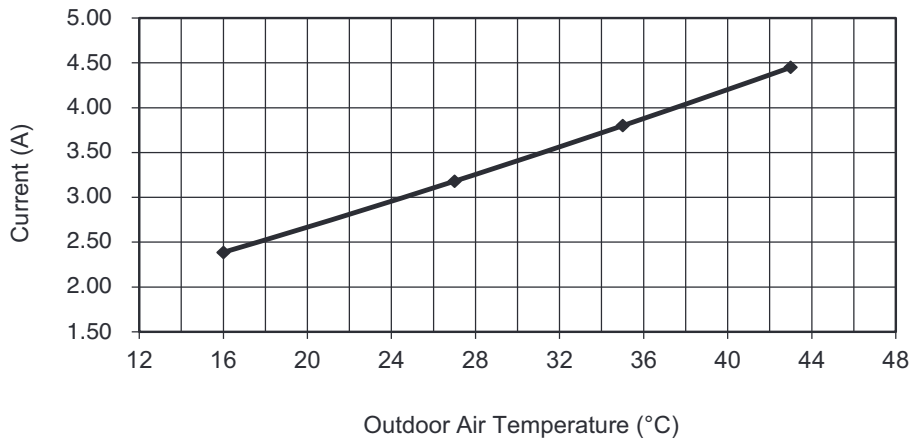
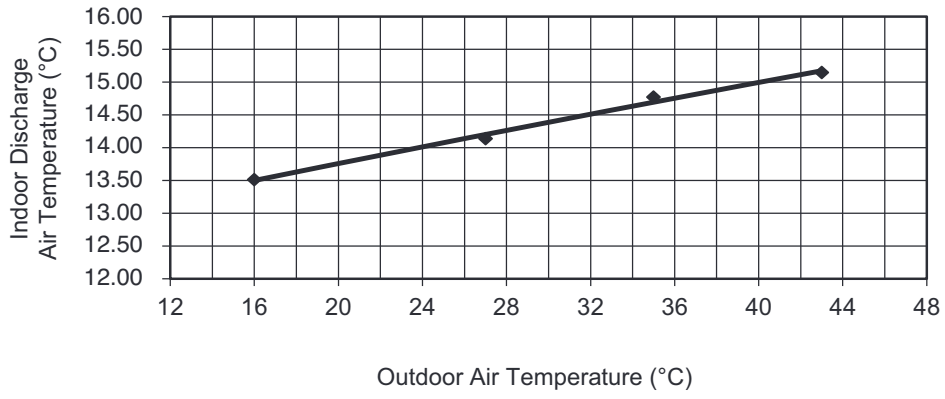

### 20.1.3 CS-Z42YKEA CU-Z42YKEA

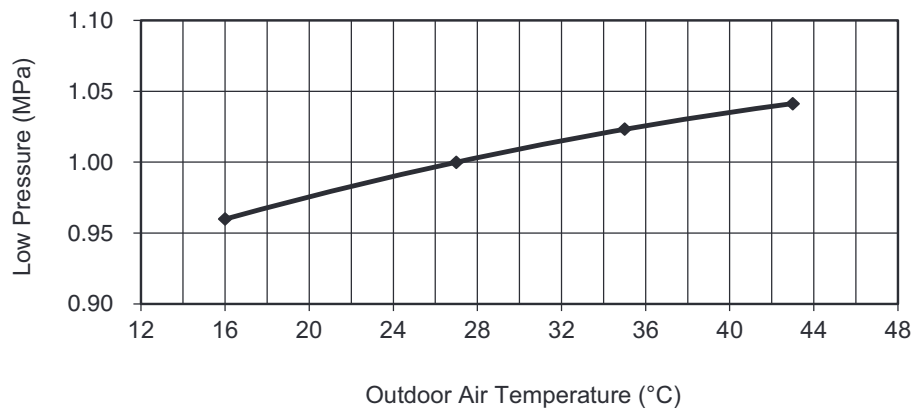
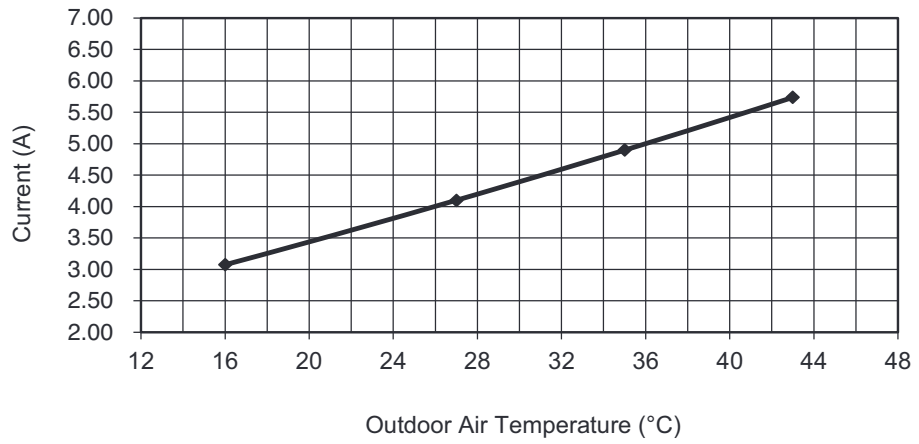
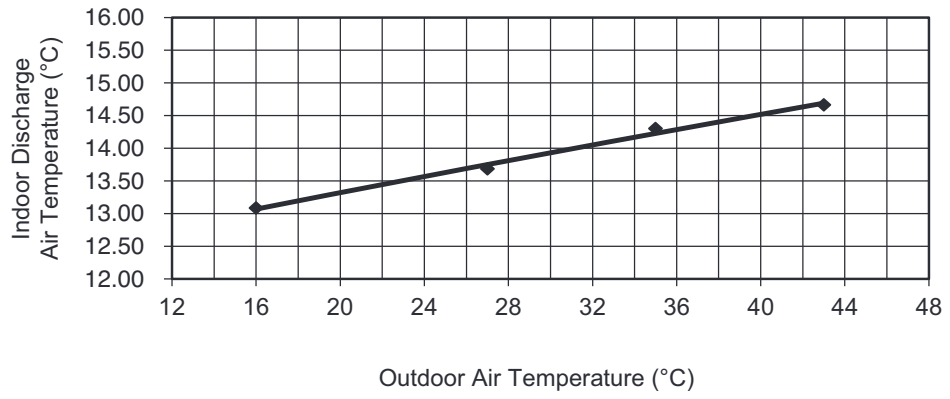

### 20.1.4 CS-Z50YKEA CU-Z50YKEA

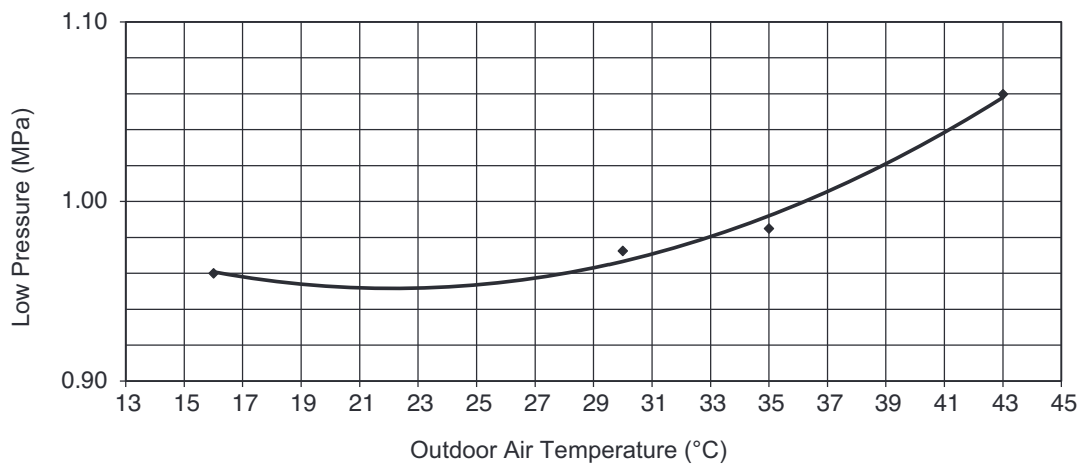
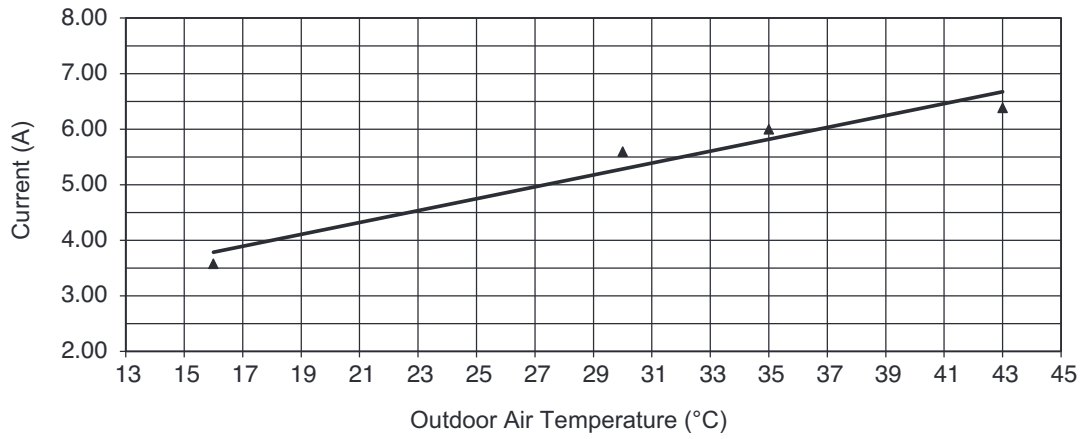
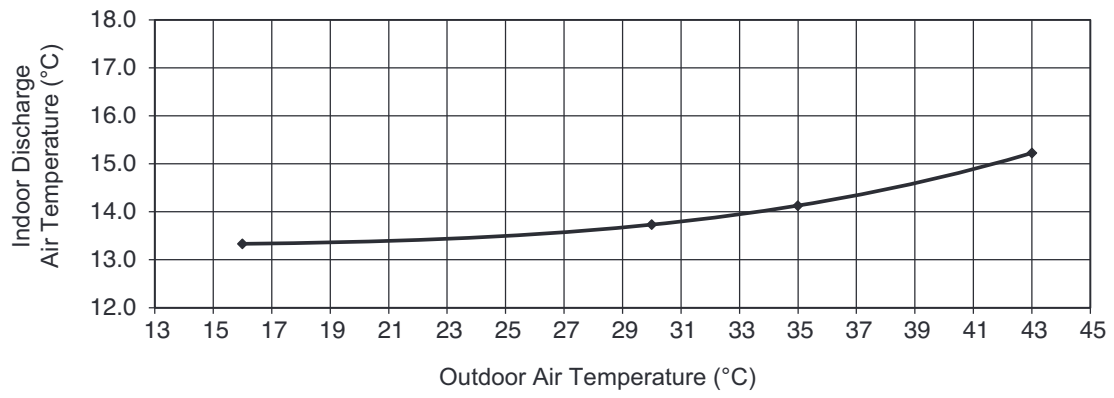

### 20.1.5 CS-Z71YKEA CU-Z71YKEA

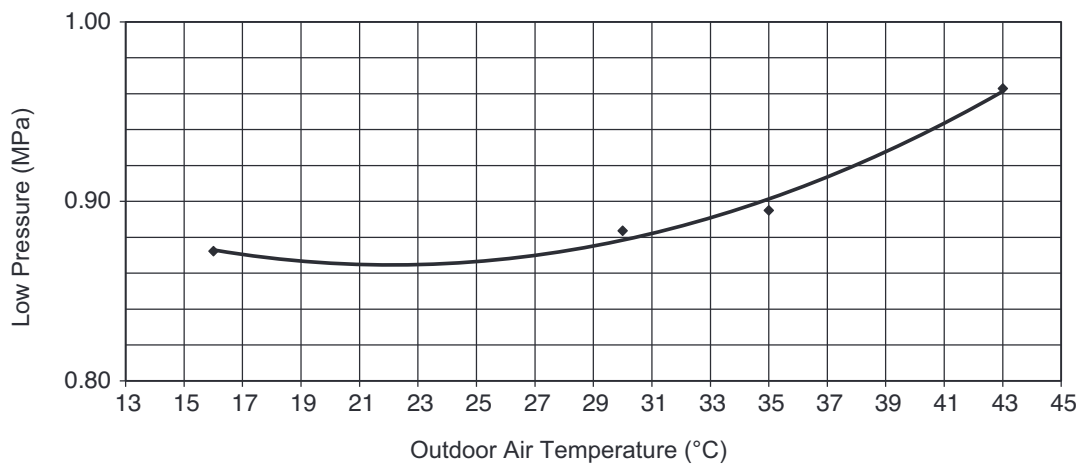
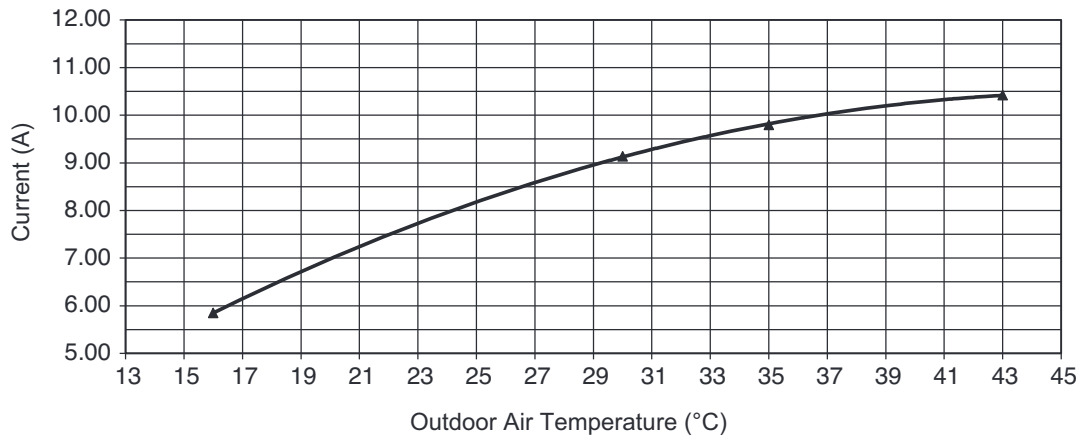
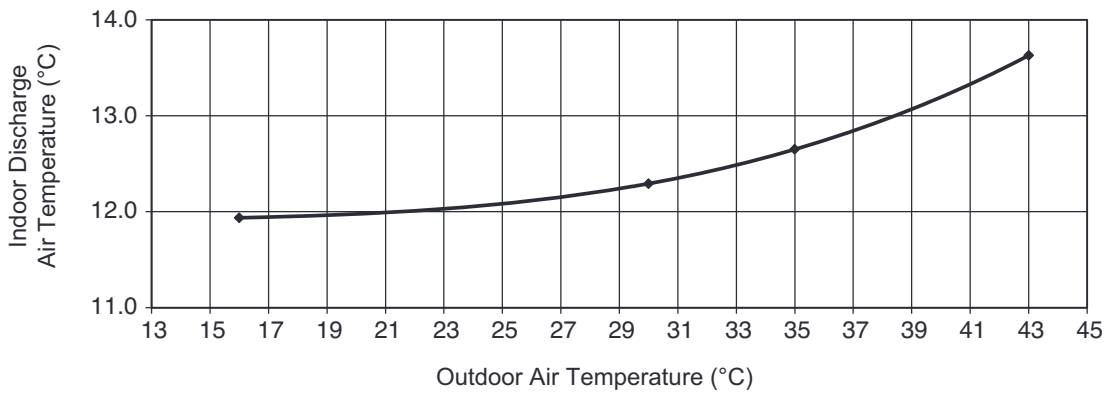

## 20.2 Heat Mode Outdoor Air Temperature Characteristic

### Condition

- Indoor room temperature: 20°C Dry Bulb/ -°C Wet Bulb
- Unit setting: Standard piping length, forced heating at 30°C, Hi fan
- Compressor frequency: Rated for Heating operation
- Piping length: 5m
- Voltage: 230V

### 20.2.1 CS-Z25YKEA CU-Z25YKEA

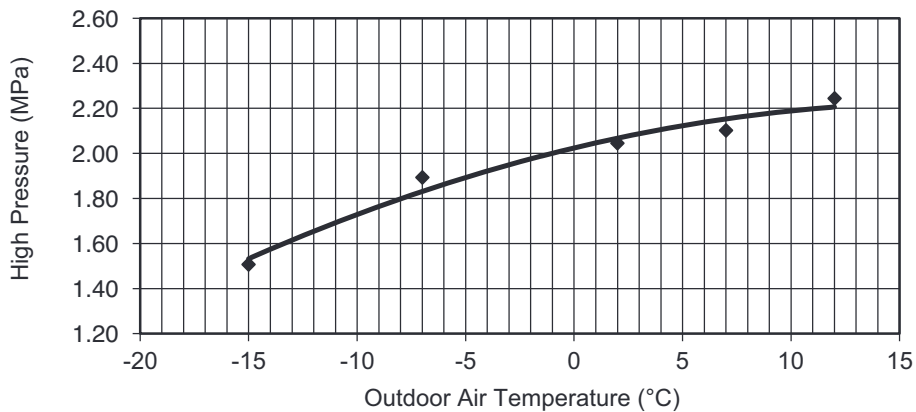
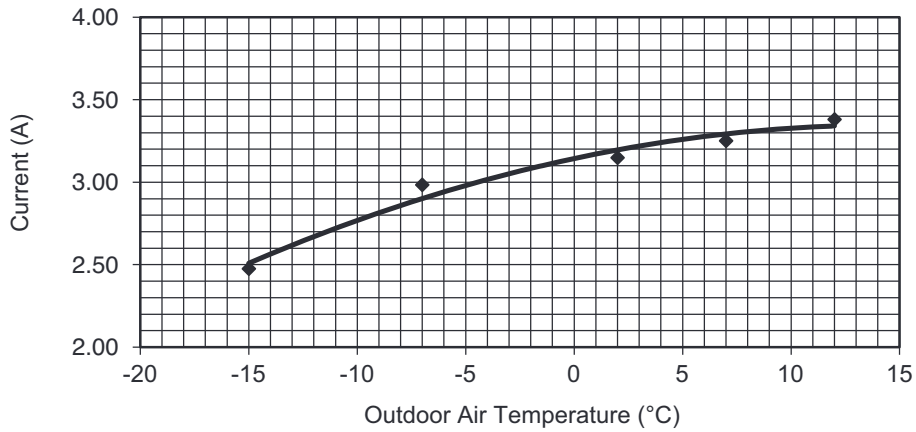
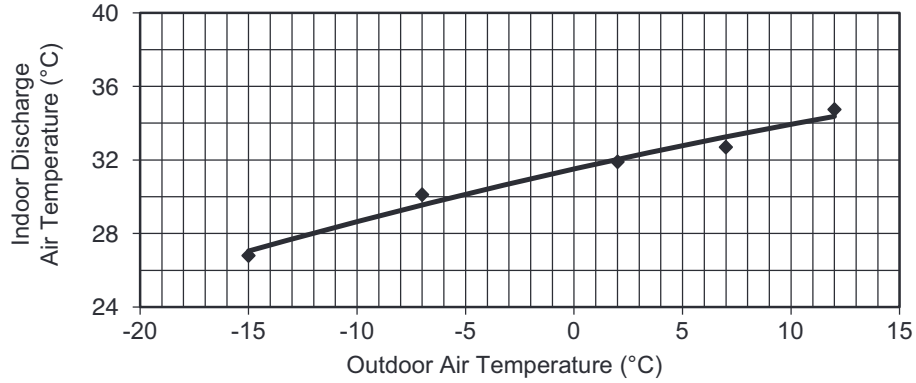

## 20.2.2 CS-Z35YKEA CU-Z35YKEA

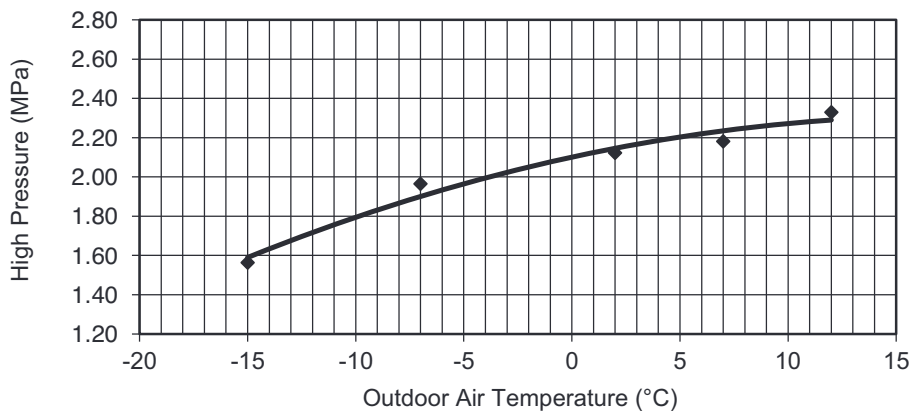
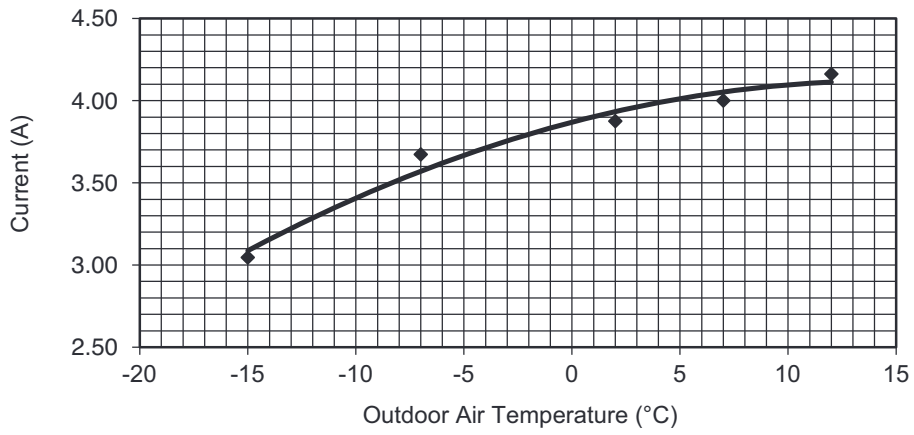
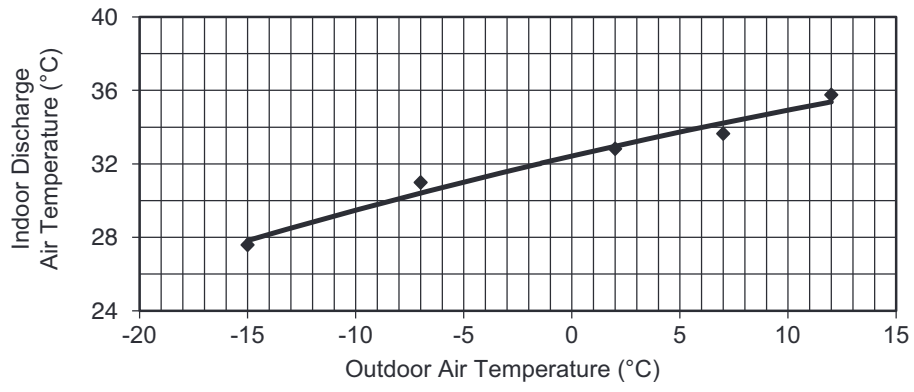

### 20.2.3 CS-Z42YKEA CU-Z42YKEA

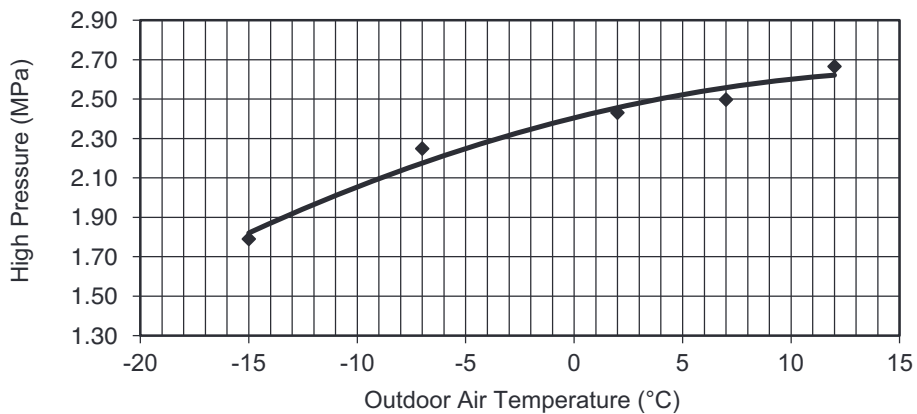
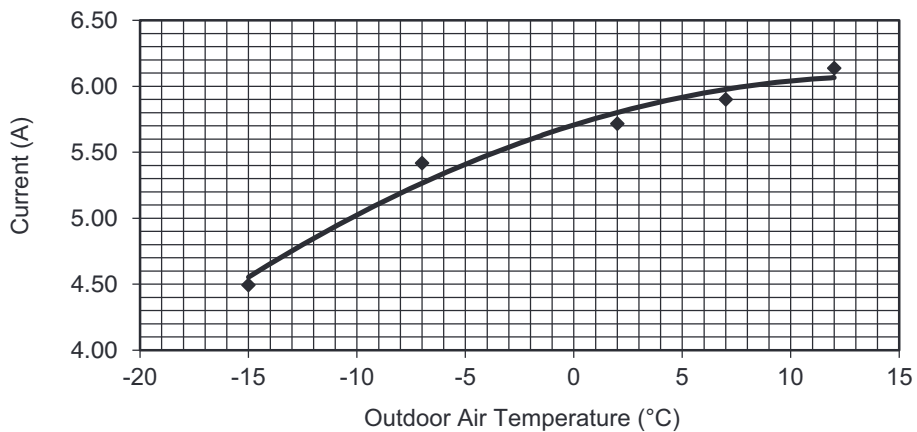
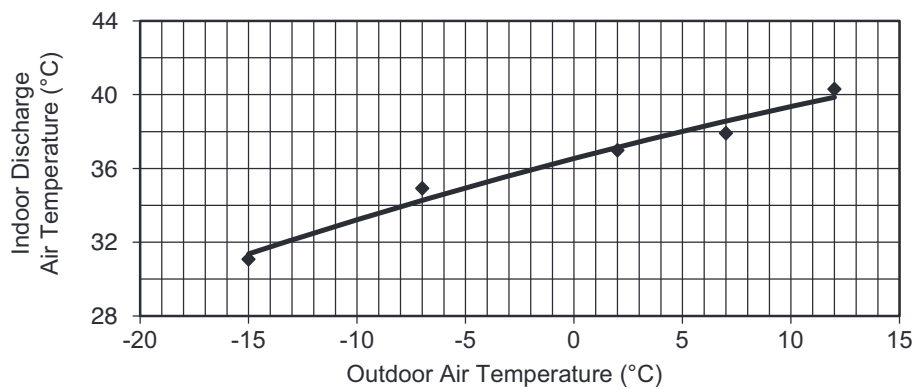

## 20.2.4 CS-Z50YKEA CU-Z50YKEA

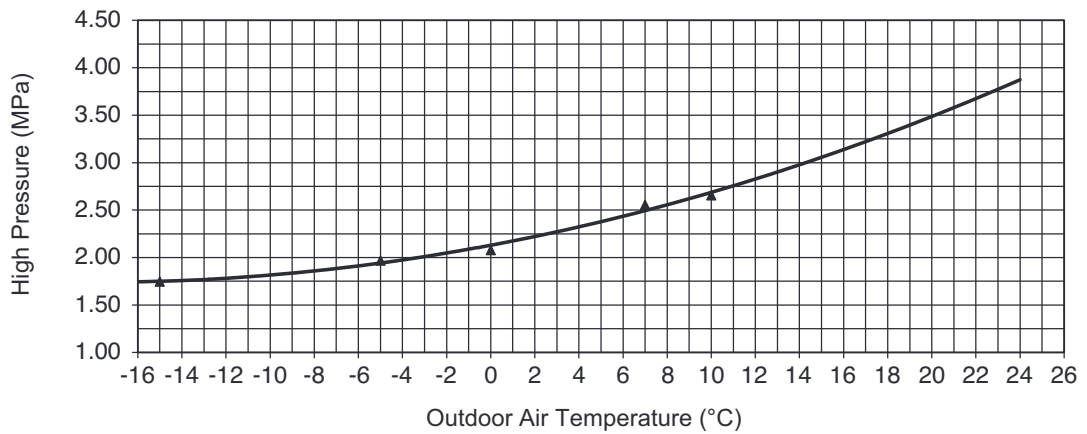
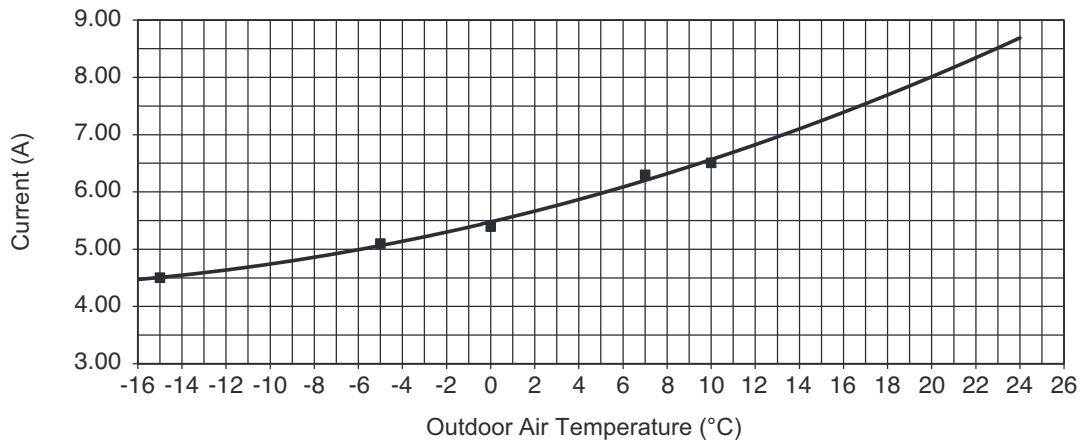
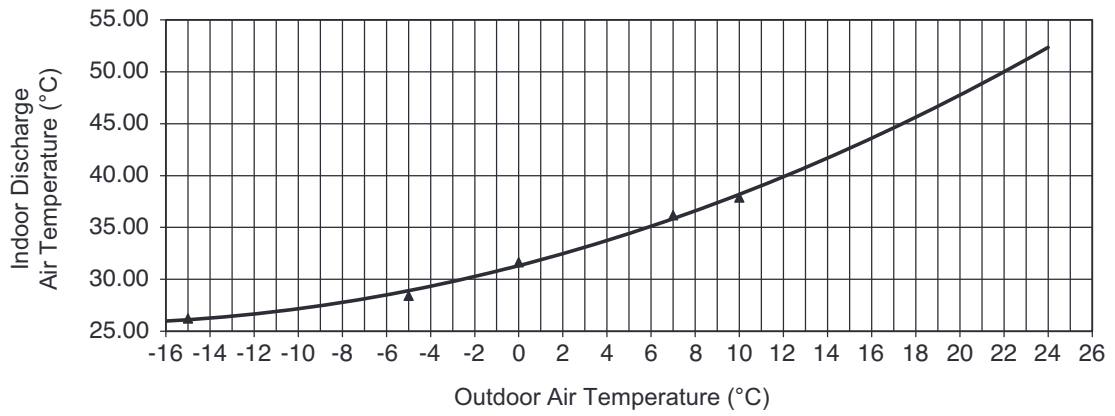

## 20.2.5 CS-Z71YKEA CU-Z71YKEA

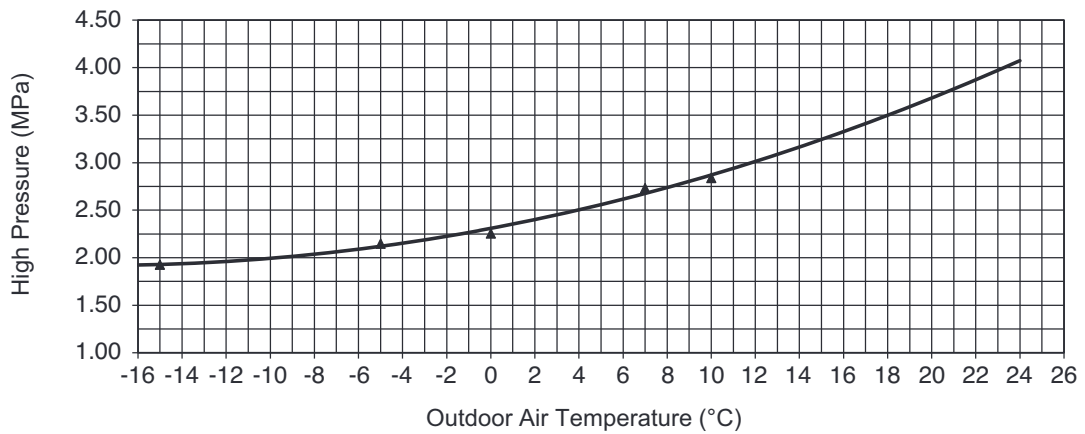
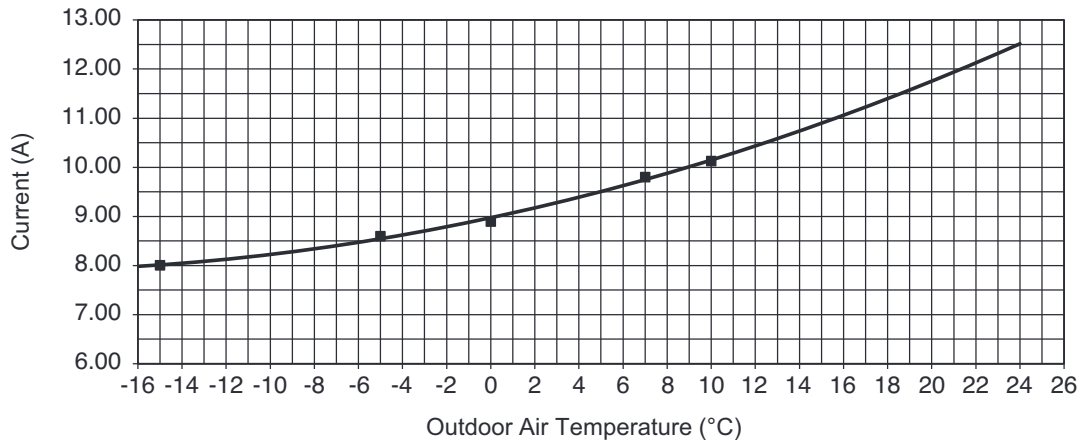
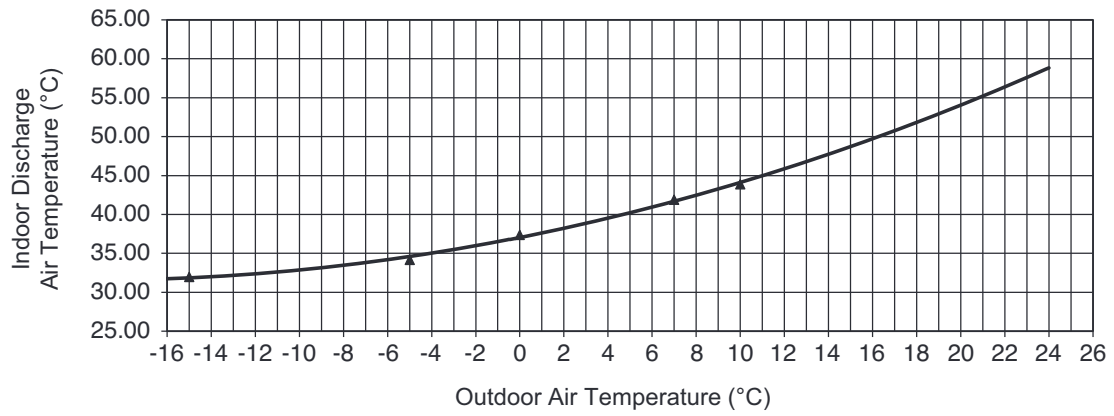

## 20.3 Piping Length Correction Factor

### 20.3.1 CS-Z25YKEA CU-Z25YKEA CS-Z35YKEA CU-Z35YKEA CS-Z42YKEA CU-Z42YKEA

The characteristic of the unit has to be corrected in accordance with the piping length.

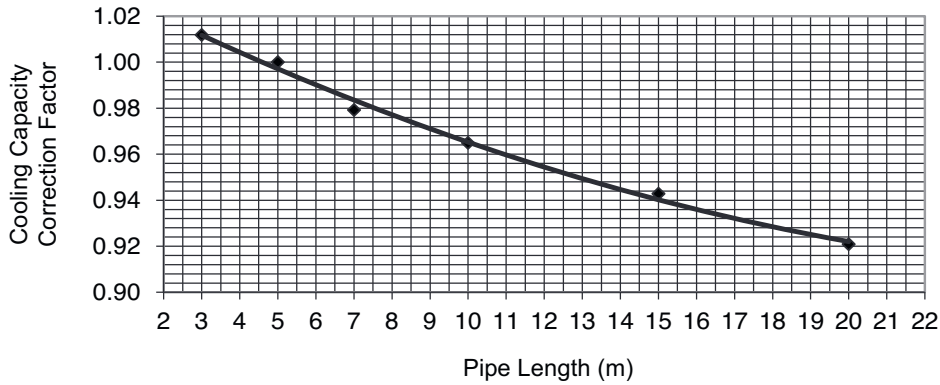

Cooling Capacity

3	1.0119
5	1.0000
7	0.9792
10	0.9650
15	0.9429
20	0.9209

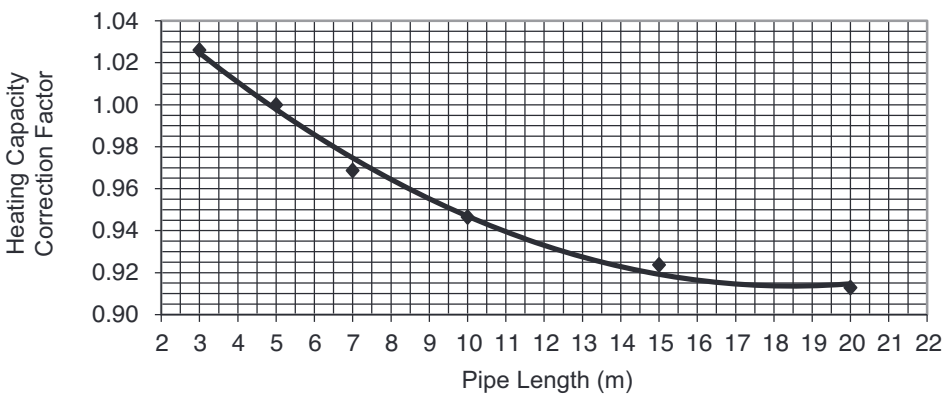

Heating Capacity

3	1.0261
5	1.0000
7	0.9687
10	0.9465
15	0.9237
20	0.9128

Note: The graphs show the factor after added right amount of additional refrigerant.

### 20.3.2 CS-Z50YKEA CU-Z50YKEA CS-Z71YKEA CU-Z71YKEA

The characteristic of the unit has to be corrected in accordance with the piping length.

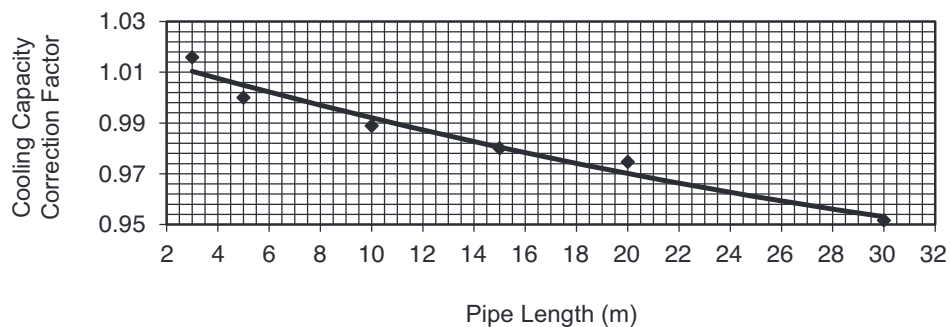

Cooling Capacity

3	1.0159
5	1.0000
10	0.9889
15	0.9800
20	0.9746
30	0.951634

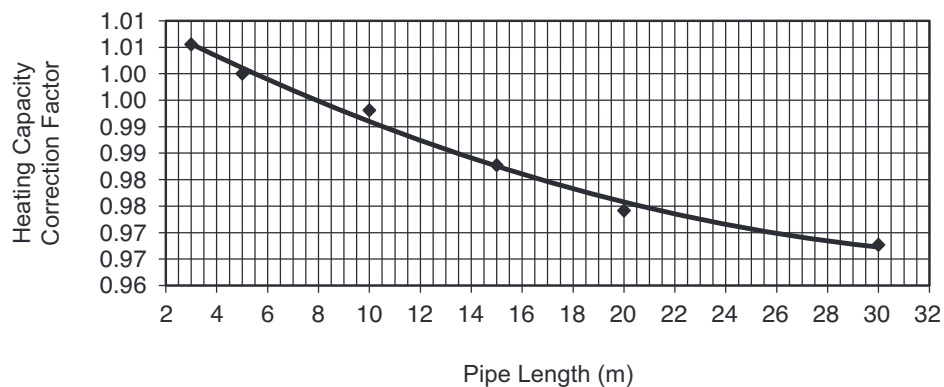

Heating Capacity

3	1.0056
5	1.0000
10	0.9931
15	0.9828
20	0.9741
30	0.9677

Note: The graphs show the factor after added right amount of additional refrigerant.

# 21. Exploded View and Replacement Parts List

## 21.1 Indoor Unit

### 21.1.1 CS-Z25YKEA CS-Z35YKEA CS-Z42YKEA

40  
CWH55025J  
▼▼▼▼▼  
CWH55051AJ  
▼▼

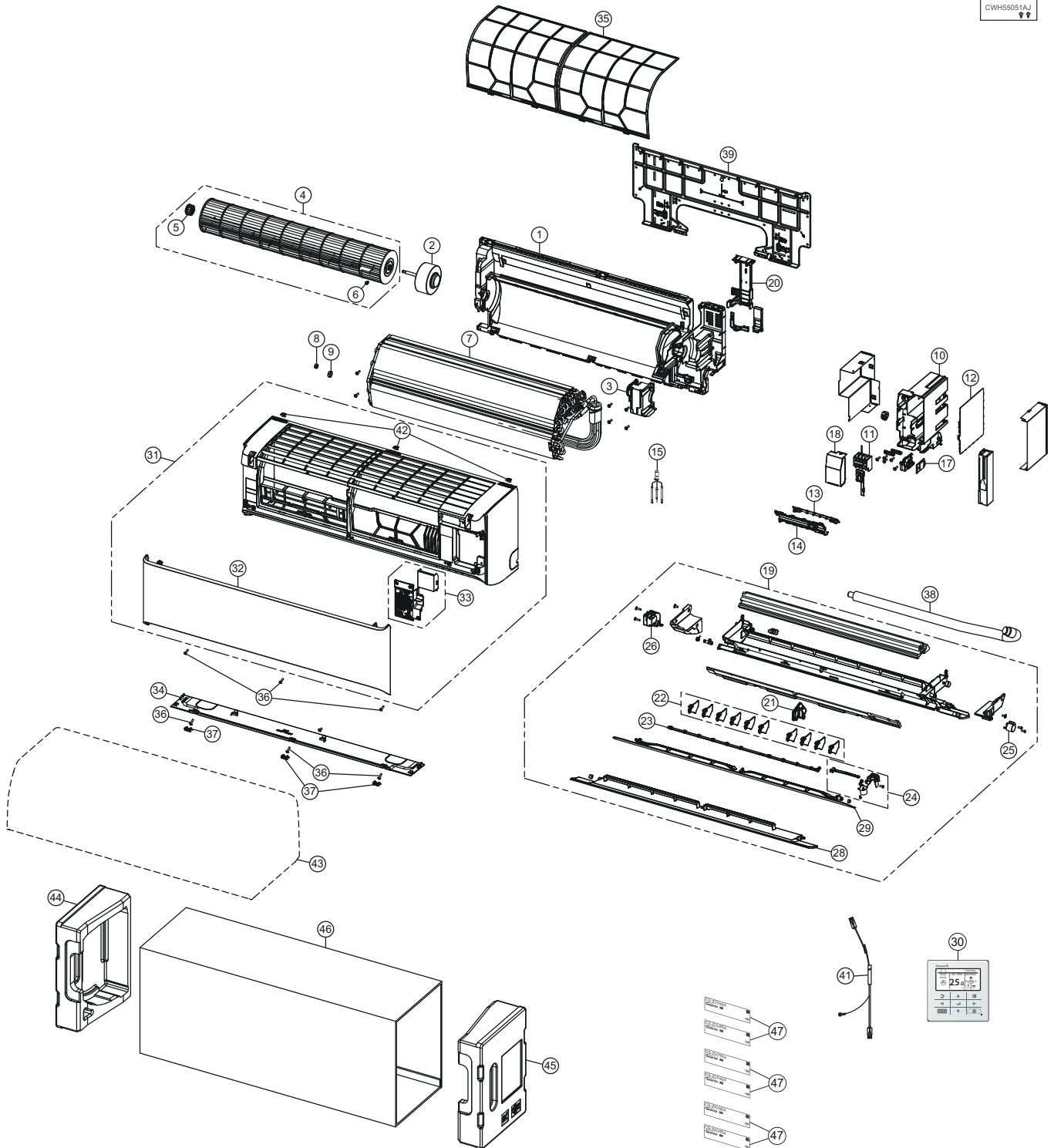

#### Note

The above exploded view is for the purpose of parts disassembly and replacement.  
The non-numbered parts are not kept as standard service parts.

SAFETY	REF. NO.	PART NAME & DESCRIPTION	QTY.	CS-Z25YKEA	CS-Z35YKEA	CS-Z42YKEA	REMARK
	1	CHASSIS COMPLETE	1	ACXD50C04160	←	←	
⚠	2	FAN MOTOR	1	L6CBYYYYL0311	←	←	
	3	FAN MOTOR BRACKET	1	ACXD54-04360	←	←	
	4	CROSS-FLOW FAN COMPLETE	1	ACXH02C01330	←	←	
	5	BEARING ASSY	1	CWH64K1010	←	←	
	6	SCREW - CROSS-FLOW FAN	1	CWH551146	←	←	
	7	EVAPORATOR	1	ACXB30C32570	←	ACXB30C35700	
	8	FLARE NUT (LIQUID)	1	CWT251048	←	←	
	9	FLARE NUT (GAS)	1	CWT251049	←	CWT251032	
	10	CONTROL BOARD CASING	1	ACXH10-08620	←	←	
⚠	11	TERMINAL BOARD COMPLETE	1	ACXA28C05840	←	←	
⚠	12	ELECTRONIC CONTROLLER - MAIN	1	ACXA73C81170	ACXA73C81180	ACXA73C81190	
⚠	13	ELECTRONIC CONTROLLER-INDICATOR	1	ACXA73-42840	←	←	
	14	INDICATOR HOLDER	1	ACXD93-22430	←	←	
⚠	15	SENSOR COMPLETE	1	CWA50C3226	←	←	
⚠	17	ELECTRONIC CONTROLLER-WIFI	1	ACXA73-28520	←	←	
	18	CONTROL BOARD COVER	1	ACXH13-08680	←	←	
	19	DISCHARGE GRILLE COMPLETE	1	ACXE20C06080	←	←	
	20	BACK COVER CHASSIS	1	ACXD93-22420	←	←	
	21	FULCRUM	1	ACXH62-00790	←	←	
	22	VERTICAL VANE	10	ACXE24-04000	←	←	
	23	CONNECTING BAR	1	ACXE26-02550	←	←	
⚠	24	AIR SWING MOTOR ASSY	1	ACXA98K00220	←	←	
⚠	25	AIR SWING MOTOR	1	ACXA98-02420	←	←	
⚠	26	GEAR-COMplete	1	ACXH68C00520	←	←	
	28	HORIZONTAL VANE COMPLETE - OUTER VANE	1	ACXE24C04660	←	←	
	29	HORIZONTAL VANE COMPLETE - INNER VANE	1	ACXE24C04670	←	←	
⚠	30	REMOTE CONTROL COMPLETE	1	ACXA75C22390	←	←	
	31	FRONT GRILLE COMPLETE	1	ACXE10C16110	←	←	
	32	INTAKE GRILLE ASSY	1	ACXE22K09860	←	←	
	33	GRILLE DOOR COMPLETE	1	ACXE14C01440	←	←	
	34	PARTICULAR PLATE	1	ACXD90-26390	←	←	
	35	AIR FILTER	2	ACXD00-02990	←	←	
	36	SCREW - FRONT GRILLE	6	XTT4+16CFJ	←	←	
	37	CAP - FRONT GRILLE	3	ACXH52-04000	←	←	
	38	DRAIN HOSE	1	ACXH85-00210	←	←	
	39	INSTALLATION PLATE	1	ACXH36-00840	←	←	
	40	BAG COMPLETE - INSTALLATION SCREW	1	CWH82C1942	←	←	
⚠	41	REMOTE CONTROL - CABEL	1	ACXA22-00600	←	←	
	42	PARTICULAR PIECE -LOCK	3	ACXD93-18690	←	←	
	43	BAG	1	ACXG86-05760	←	←	
	44	SHOCK ABSORBER - LEFT	1	ACXG70-12960	←	←	
	45	SHOCK ABSORBER - RIGHT	1	ACXG70-12970	←	←	

SAFETY	REF. NO.	PART NAME & DESCRIPTION	QTY.	CS-Z25YKEA	CS-Z35YKEA	CS-Z42YKEA	REMARK
	46	C.C.CASE	1	ACXG50-57101	←	←	
	47	MODEL LABEL	2	ACXF85-85490	ACXF85-85500	ACXF85-85510	

(NOTE)

- All parts are supplied from PAPAMY, Malaysia (Vendor Code: 00029488).
- "O" marked parts are recommended to be kept in stock.

## 21.1.2 CS-Z50YKEA CS-Z71YKEA

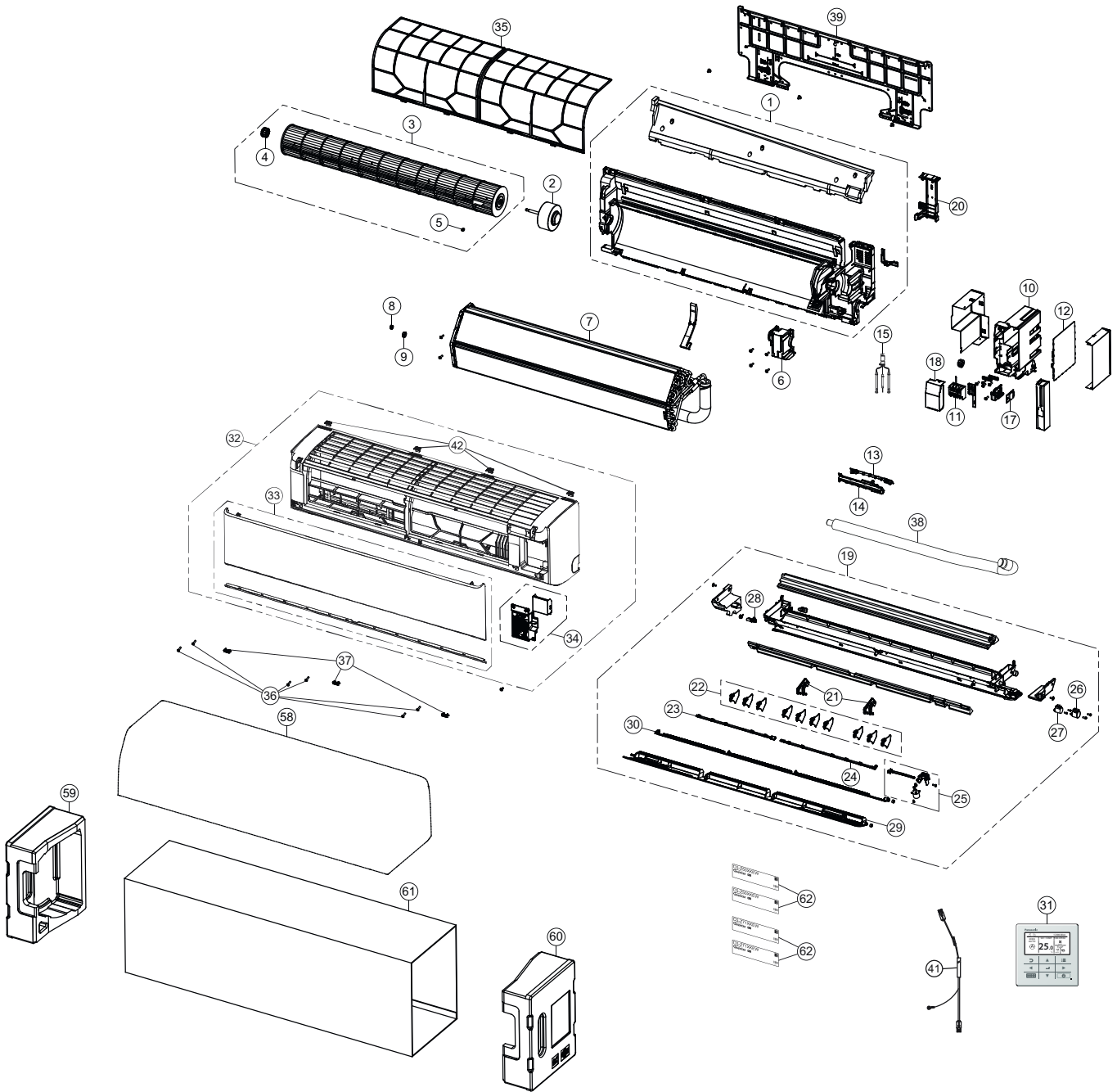

**Note**  
 The above exploded view is for the purpose of parts disassembly and replacement.  
 The non-numbered parts are not kept as standard service parts.

SAFETY	REF. NO.	PART NAME & DESCRIPTION	QTY.	CS-Z50YKEA	CS-Z71YKEA	REMARK
	1	CHASSIS COMPLETE	1	ACXD50C04220	←	
⚠	2	FAN MOTOR	1	L6CBYYL0376	L6CBYYL0411	O
	3	CROSS-FLOW FAN COMPLETE	1	ACXH02C01450	←	
	4	BEARING ASSY	1	CWH64K1006	←	
	5	SCREW - CROSS-FLOW FAN	1	CWH551146	←	
	6	FAN MOTOR BRACKET	1	ACXD54-04360	←	
	7	EVAPORATOR	1	ACXB30C33300	ACXB30C35590	
	8	FLARE NUT (LIQUID)	1	CWT251048	←	
	9	FLARE NUT (GAS)	1	CWT251032	CWT251033	
	10	CONTROL BOARD CASING	1	ACXH10-08620	←	
⚠	11	TERMINAL BOARD COMPLETE	1	ACXA28C05910	←	O
⚠	12	ELECTRONIC CONTROLLER - MAIN	1	ACXA73C81200	ACXA73C81210	O
⚠	13	ELECTRONIC CONTROLLER-INDICATOR	1	ACXA73-42840	←	O
	14	INDICATOR HOLDER	1	ACXD93-22840	←	
⚠	15	SENSOR COMPLETE	1	ACXA50C17750	CWA50C2664	O
⚠	17	ELECTRONIC CONTROLLER-WIFI	1	ACXA73-28520	←	O
	18	CONTROL BOARD COVER	1	ACXH13-08680	←	
	19	DISCHARGE GRILLE COMPLETE	1	ACXE20C06380	←	
	20	BACK COVER CHASSIS	1	ACXD93-22420	←	
	21	FULCRUM	2	ACXH62-00810	←	
	22	VERTICAL VANE	10	ACXE24-04000	←	
	23	CONNECTING BAR - LEFT	1	ACXE26-02640	←	
	24	CONNECTING BAR - RIGHT	1	ACXE26-02650	←	
⚠	25	AIR SWING MOTOR ASSY	1	ACXA98K00220	←	O
⚠	26	AIR SWING MOTOR	1	ACXA98-02980	←	O
⚠	27	AIR SWING MOTOR	1	ACXA98-02950	←	O
	29	HORIZONTAL VANE COMPLETE - OUTER	1	ACXE24C04910	←	
	30	HORIZONTAL VANE COMPLETE - INNER	1	ACXE24C04760	←	
⚠	31	REMOTE CONTROL COMPLETE	1	ACXA75C22390	←	O
	32	FRONT GRILLE COMPLETE	1	ACXE10C15900	ACXE10C15740	
	33	INTAKE GRILLE ASSY	1	ACXE22C04450	←	
	34	GRILLE DOOR COMPLETE	1	ACXE14C01440	←	
	35	AIR FILTER	2	ACXD00-03050	←	
	36	SCREW - FRONT GRILLE	6	XTT4+16CFJ	←	
	37	CAP - FRONT GRILLE	3	ACXH52-04000	←	
	38	DRAIN HOSE	1	ACXH85-00210	←	
	39	INSTALLATION PLATE	1	ACXH36-00880	←	
	40	BAG COMPLETE - INSTALLATION SCREW	1	CWH82C1942	←	
⚠	41	REMOTE CONTROL - CABEL	1	ACXA22-00600	←	O
	42	PARTICULAR PIECE -LOCK	4	ACXD93-18690	←	
	58	BAG	1	ACXG86-05770	←	
	59	SHOCK ABSORBER - LEFT	1	ACXG70-13280	←	
	60	SHOCK ABSORBER - RIGHT	1	ACXG70-13290	←	

SAFETY	REF. NO.	PART NAME & DESCRIPTION	QTY.	CS-Z50YKEA	CS-Z71YKEA	REMARK
	61	C.C.CASE	1	ACXG50-57181	←	
	62	MODEL LABEL	2	ACXF85-85520	ACXF85-85530	

(NOTE)

- All parts are supplied from PAPAMY, Malaysia (Vendor Code: 00029488).
- "O" marked parts are recommended to be kept in stock.

## 21.2 Outdoor Unit

### 21.2.1 CU-Z25YKEA CU-Z35YKEA CU-Z42YKEA

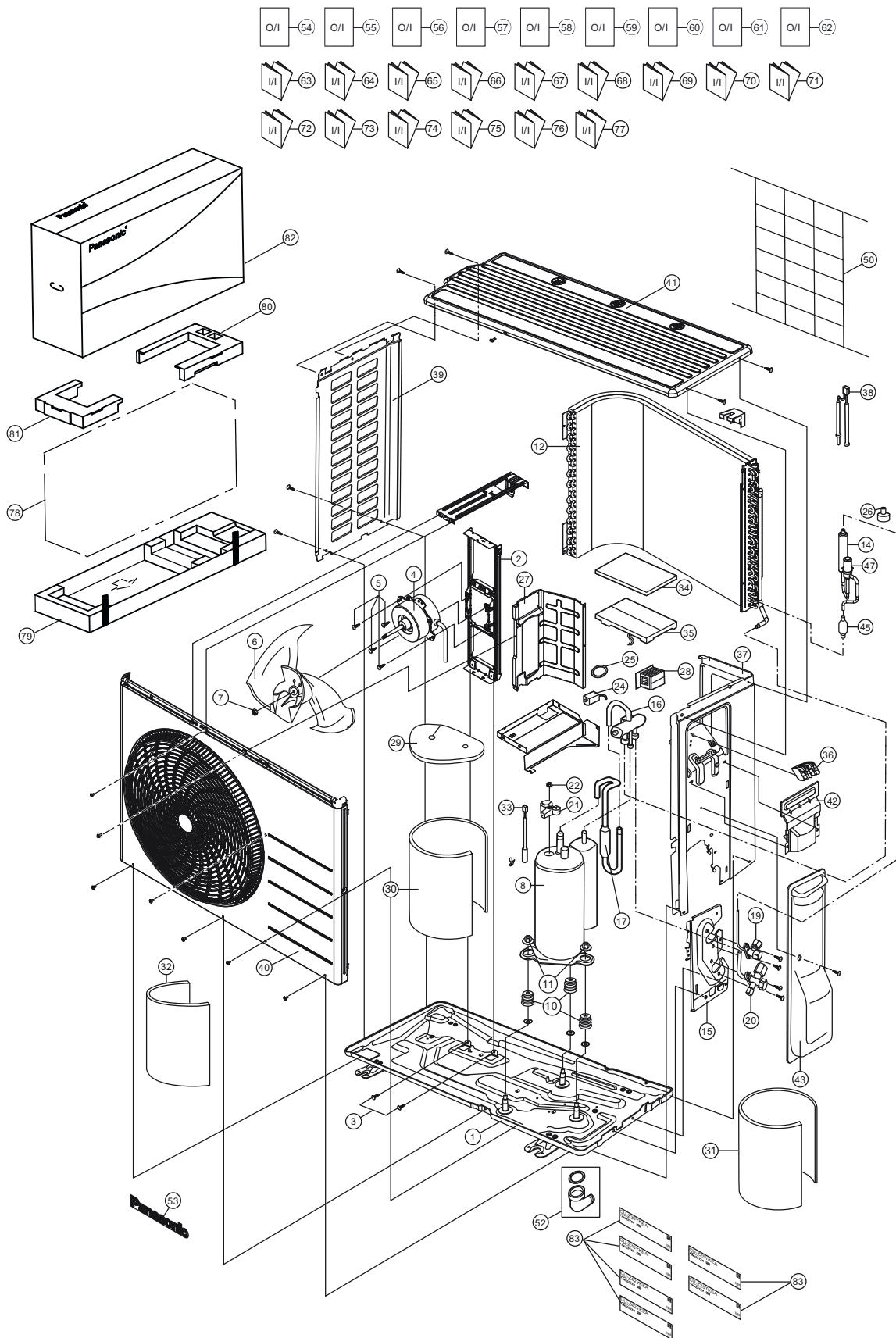

#### Note

The above exploded view is for the purpose of parts disassembly and replacement.  
The non-numbered parts are not kept as standard service parts.

SAFETY	REF. NO.	PART NAME & DESCRIPTION	QTY.	CU-Z25YKEA	CU-Z35YKEA	CU-Z42YKEA	REMARK
	1	CHASSIS COMPLETE	1	CWD52K1399	←	←	
	2	FAN MOTOR BRACKET	1	CWD541157	←	←	
	3	SCREW - FAN MOTOR BRACKET	2	ACXH55-07140	←	←	
⚠	4	FAN MOTOR	1	L6CAYYYL0156	←	←	
	5	SCREW - FAN MOTOR MOUNT	4	CWH55252J	←	←	
	6	PROPELLER FAN ASSY	1	CWH03K1100	←	←	
	7	NUT - PROPELLER FAN	1	CWH56053J	←	←	
⚠	8	COMPRESSOR	1	9RS102XRA21	←	←	
	10	ANTI - VIBRATION BUSHING	3	CWH50077	←	←	
	11	NUT - COMPRESSOR MOUNT	3	CWH561096	←	←	
	12	CONDENSER	1	ACXB32C23130	←	←	
	14	DISCHARGE MUFFLER	1	CWB121021	←	←	
	15	HOLDER COUPLING	1	CWH351233	←	←	
	16	4-WAYS VALVE	1	ACXB00-01290	←	←	
	17	DISCHARGE MUFFLER (4 W.VALVE)	1	CWB121010	←	←	
	19	2-WAYS VALVE (LIQUID)	1	ACXB02-03310	←	←	
	20	3-WAY VALVE (GAS)	1	ACXB01-04540	←	ACXB01-02280	
	21	TERMINAL COVER	1	CWH171039A	←	←	
	22	NUT - TERMINAL COVER	1	CWH7080300J	←	←	
⚠	24	V-COIL COMPLETE - 4-WAY VALVE	1	ACXA43C00250	←	←	
⚠	26	V-COIL COMPLETE - EXP. VALVE	1	ACXA43C06110	←	←	
	27	SOUND PROOF BOARD	1	CWH151428	←	←	
⚠	28	REACTOR	1	G0C392J00037	←	G0C392J00050	
	29	SOUND PROOF MATERIAL - COMP. TOP	1	CWG302314	←	←	
	30	SOUND PROOF MATERIAL - COMP. BODY	1	ACXG30-11540	←	←	
	31	SOUND PROOF MATERIAL - SOUND PROOF BOARD	1	ACXG30-11800	←	←	
	32	SOUND PROOF MATERIAL - CABINET SIDE PLATE	1	CWG302994	←	←	
⚠	33	SENSOR CO-COMP TEMP	1	ACXA50C17380	←	←	
	34	CONTROL BOARD COVER-TOP	1	ACXH13-00450	←	←	
⚠	35	ELECTRONIC CONTROLLER - MAIN	1	ACXA73C83680R	ACXA73C83690R	ACXA73C83700R	
⚠	36	TERMINAL BOARD ASSY	1	CWA28K1036J	←	←	
	37	CABINET SIDE PLATE CO.	1	ACXE04C00460	←	←	
⚠	38	SENSOR CO-AIR TEMP AND PIPE TEMP	1	CWA50C3079	←	←	
	39	CABINET SIDE PLATE	1	CWE041858A	←	←	
	40	CABINET FRONT PLATE CO.	1	CWE06C1566	←	←	
	41	CABINET TOP PLATE	1	CWE031230A	←	←	
	42	PLATE - C. B. COVER TERMINAL	1	CWH131301	←	←	
	43	CONTROL BOARD COVER CO.	1	CWH13C1359	←	←	
	45	STRAINER	1	CWB11094	←	←	
	47	EXPANSION VALVE	1	ACXB05-01080	←	←	
	50	WIRE NET	1	ACXD04-00040A	←	←	
	52	ACCESSORY-COMPLETE	1	ACXH82C21740	←	←	
	53	BADGE	1	CWE373439	←	←	
	54	OPERATING INSTRUCTION	1	ACXF55-32680	←	←	
	55	OPERATING INSTRUCTION	1	ACXF55-32690	←	←	
	56	OPERATING INSTRUCTION	1	ACXF55-33180	←	←	

SAFETY	REF. NO.	PART NAME & DESCRIPTION	QTY.	CU-Z25YKEA	CU-Z35YKEA	CU-Z42YKEA	REMARK
	57	OPERATING INSTRUCTION	1	ACXF55-32700	←	←	
	58	OPERATING INSTRUCTION	1	ACXF55-32710	←	←	
	59	OPERATING INSTRUCTION	1	ACXF55-30282	←	←	
	60	OPERATING INSTRUCTION	1	ACXF55-30292	←	←	
	61	OPERATING INSTRUCTION	1	ACXF55-30302	←	←	
	62	OPERATING INSTRUCTION	1	ACXF55-28413	←	←	
	63	INSTALLATION INSTRUCTION	1	ACXF60-45640	←	←	
	64	INSTALLATION INSTRUCTION	1	ACXF60-45650	←	←	
	65	INSTALLATION INSTRUCTION	1	ACXF60-45660	←	←	
	66	INSTALLATION INSTRUCTION	1	ACXF60-45670	←	←	
	67	INSTALLATION INSTRUCTION	1	ACXF60-45680	←	←	
	68	INSTALLATION INSTRUCTION	1	ACXF60-45690	←	←	
	69	INSTALLATION INSTRUCTION	1	ACXF60-45700	←	←	
	70	INSTALLATION INSTRUCTION	1	ACXF60-45710	←	←	
	71	INSTALLATION INSTRUCTION	1	ACXF60-45720	←	←	
	72	INSTALLATION INSTRUCTION	1	ACXF60-45730	←	←	
	73	INSTALLATION INSTRUCTION	1	ACXF60-45740	←	←	
	74	INSTALLATION INSTRUCTION	1	ACXF60-45750	←	←	
	75	INSTALLATION INSTRUCTION	1	ACXF60-45760	←	←	
	76	INSTALLATION INSTRUCTION	1	ACXF60-45770	←	←	
	77	INSTALLATION INSTRUCTION	1	ACXF60-45780	←	←	
	78	BAG	1	ACXG86-05700	←	←	
	79	BASE BOARD-COMPLETE	1	ACXG62C02400	←	←	
	80	SHOCK ABSORBER - RIGHT	1	ACXG70-14420A	←	←	
	81	SHOCK ABSORBER - LEFT	1	ACXG70-14430A	←	←	
	82	C.C.CASE	1	ACXG50-48862	←	←	
	83	MODEL LABEL	2	ACXF85-85670	ACXF85-85680	ACXF85-85690	

(NOTE)

- All parts are supplied from PAPAMY, Malaysia (Vendor Code: 00029488).
- "O" marked parts are recommended to be kept in stock.

## 21.2.2 CU-Z50YKEA

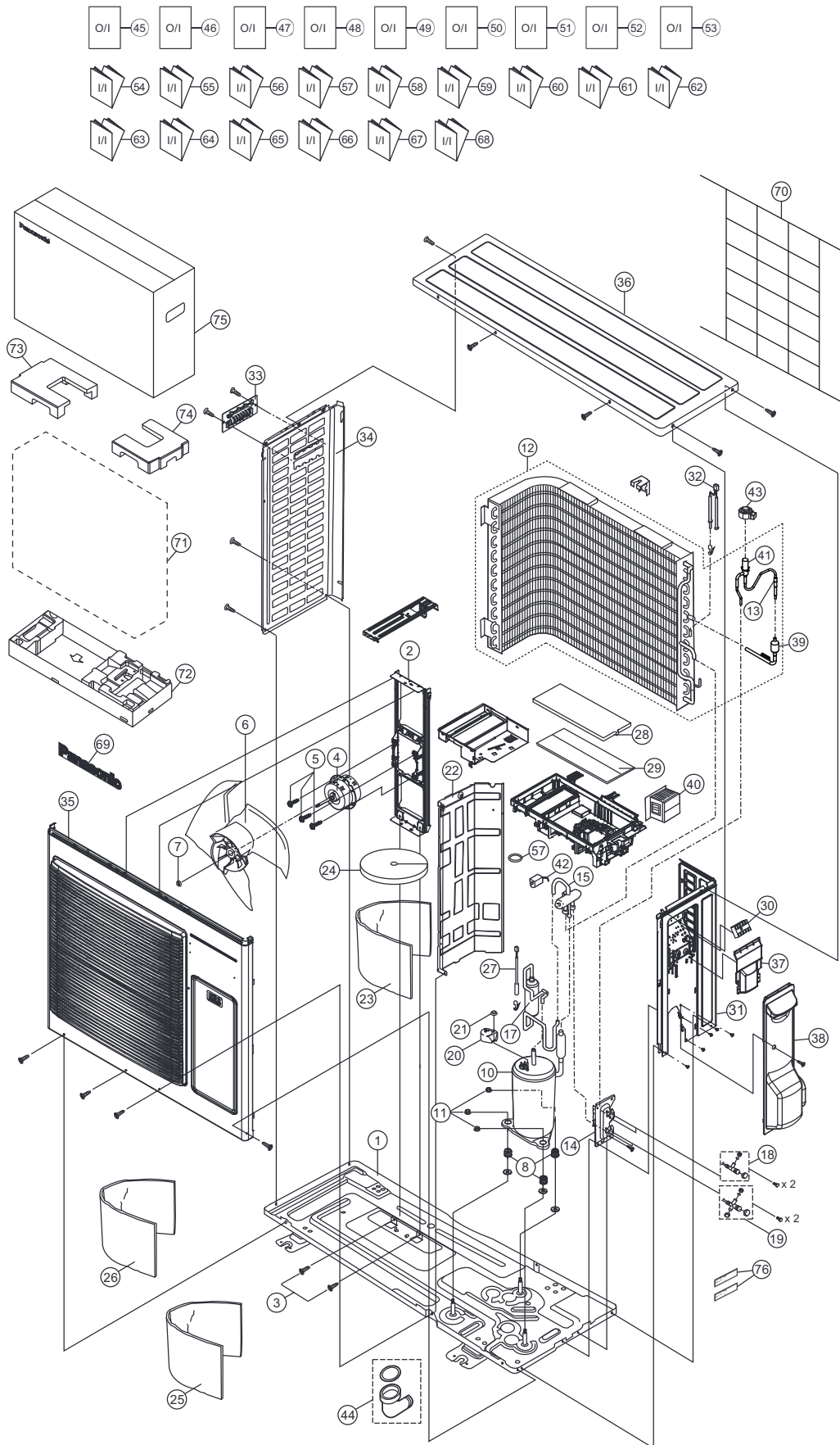

**Note**  
 The above exploded view is for the purpose of parts disassembly and replacement.  
 The non-numbered parts are not kept as standard service parts.

SAFETY	REF. NO.	PART NAME & DESCRIPTION	QTY.	CU-Z50YKEA	REMARK
	1	CHASSIS COMPLETE	1	ACXD52K00320	
	2	FAN MOTOR BRACKET	1	ACXD54-00140	
	3	SCREW - FAN MOTOR BRACKET	2	ACXH55-07140	
⚠	4	FAN MOTOR	1	L6CAYYYL0169	O
	5	SCREW - FAN MOTOR MOUNT	4	CWH551106J	
	6	PROPELLER FAN ASSY	1	ACXH03K00070	
	7	NUT - PROPELLER FAN	1	CWH56053J	
	8	ANTI - VIBRATION BUSHING	3	CWH50077	
⚠	10	COMPRESSOR	1	9RD132XGA21	O
	11	NUT - COMPRESSOR MOUNT	3	CWH561096	
	12	CONDENSER	1	ACXB32C23401	
	13	STRAINER	1	ACXB11-01560	
	14	HOLDER COUPLING	1	ACXH35-00080	
	15	4-WAYS VALVE	1	ACXB00-00140	
	17	DISCHARGE MUFFLER(4 W.VALVE)	1	ACXB12-01060	
	18	2-WAYS VALVE (LIQUID)	1	ACXB02-03430	
	19	3-WAY VALVE (GAS)	1	ACXB01-00580	
	20	TERMINAL COVER	1	CWH171039A	
	21	NUT - TERMINAL COVER	1	CWH7080300J	
	22	SOUND PROOF BOARD	1	ACXH15-00200	
	23	SOUND PROOF MATERIAL - COMP. BODY	1	ACXG30-11560	
	24	SOUND PROOF MATERIAL - COMP. TOP	1	ACXG30-11550	
	25	SOUND PROOF MATERIAL	1	ACXG30-11880	
	26	SOUND PROOF MATERIAL	1	CWG302632	
⚠	27	SENSOR CO-COMP TEMP	1	ACXA50C17400	O
	28	CONTROL BOARD COVER-TOP	1	ACXH13-00490	
⚠	29	ELECTRONIC CONTROLLER - MAIN	1	ACXA73C83710R	O
⚠	30	TERMINAL BOARD ASSY	1	CWA28K1036J	O
	31	CABINET SIDE PLATE CO.	1	ACXE04C00720	
⚠	32	SENSOR CO-AIR TEMP AND PIPE TEMP	1	CWA50C3079	O
	33	HANDLE	1	CWE161010	
	34	CABINET SIDE PLATE	1	ACXE04-00580	
	35	CABINET FRONT PLATE CO.	1	ACXE06K00080	
	36	CABINET TOP PLATE	1	ACXE03-00200	
	37	PLATE - C. B. COVER TERMINAL	1	CWH131470	
	38	CONTROL BOARD COVER CO.	1	ACXH13C00170	
	39	STRAINER	1	CWB11094	
⚠	40	REACTOR	1	G0C392J00027	O
	41	EXPANSION VALVE	1	ACXB05-01080	
⚠	42	V-COIL COMPLETE - 4-WAY VALVE	1	ACXA43C00250	O
⚠	43	V-COIL COMPLETE - EXP.VALVE	1	ACXA43C06110	O
	44	ACCESSORY-COMPLETE	1	ACXH82C21740	
	45	OPERATING INSTRUCTION	1	ACXF55-32680	
	46	OPERATING INSTRUCTION	1	ACXF55-32690	
	47	OPERATING INSTRUCTION	1	ACXF55-33180	
	48	OPERATING INSTRUCTION	1	ACXF55-32700	
	49	OPERATING INSTRUCTION	1	ACXF55-32710	

SAFETY	REF. NO.	PART NAME & DESCRIPTION	QTY.	CU-Z50YKEA	REMARK
	50	OPERATING INSTRUCTION	1	ACXF55-30282	
	51	OPERATING INSTRUCTION	1	ACXF55-30292	
	52	OPERATING INSTRUCTION	1	ACXF55-30302	
	53	OPERATING INSTRUCTION	1	ACXF55-28413	
	54	INSTALLATION INSTRUCTION	1	ACXF60-45640	
	55	INSTALLATION INSTRUCTION	1	ACXF60-45650	
	56	INSTALLATION INSTRUCTION	1	ACXF60-45660	
	57	INSTALLATION INSTRUCTION	1	ACXF60-45670	
	58	INSTALLATION INSTRUCTION	1	ACXF60-45680	
	59	INSTALLATION INSTRUCTION	1	ACXF60-45690	
	60	INSTALLATION INSTRUCTION	1	ACXF60-45700	
	61	INSTALLATION INSTRUCTION	1	ACXF60-45710	
	62	INSTALLATION INSTRUCTION	1	ACXF60-45720	
	63	INSTALLATION INSTRUCTION	1	ACXF60-45730	
	64	INSTALLATION INSTRUCTION	1	ACXF60-45740	
	65	INSTALLATION INSTRUCTION	1	ACXF60-45750	
	66	INSTALLATION INSTRUCTION	1	ACXF60-45760	
	67	INSTALLATION INSTRUCTION	1	ACXF60-45770	
	68	INSTALLATION INSTRUCTION	1	ACXF60-45780	
	69	BADGE	1	CWE373439	
	70	WIRE NET	1	ACXD04-00130A	
	71	BAG	1	ACXG86-05720	
	72	BASE BOARD-COMPLETE	1	ACXG62C02440	
	73	SHOCK ABSORBER - TOP LEFT	1	ACXG70-14460A	
	74	SHOCK ABSORBER - TOP RIGHT	1	ACXG70-14470A	
	75	C.C.CASE	1	ACXG50-48882	
	76	MODEL LABEL	2	ACXF85-85700	

(NOTE)

- All parts are supplied from PAPAMY, Malaysia (Vendor Code: 00029488).
- "O" marked parts are recommended to be kept in stock.

## 21.2.3 CU-Z71YKEA

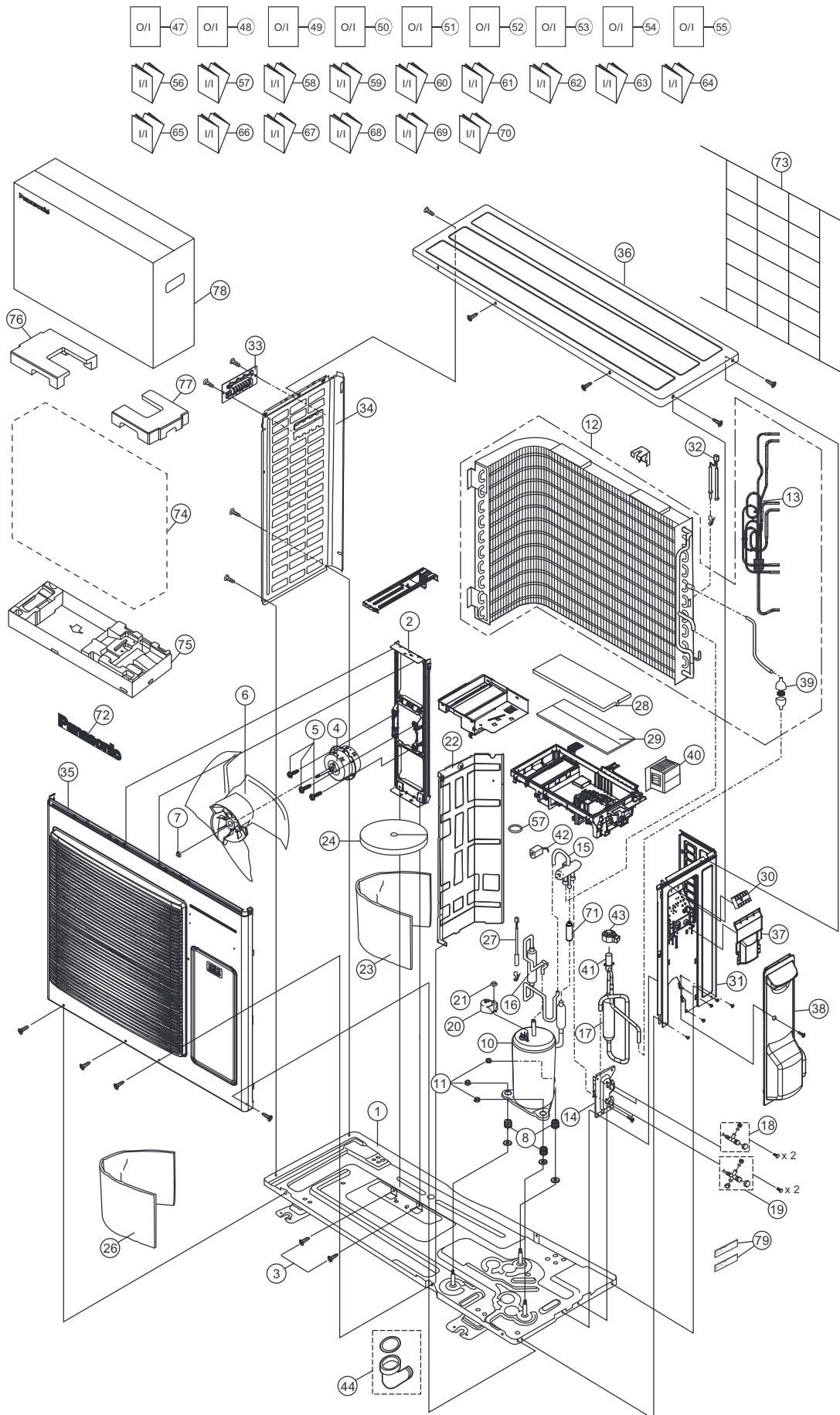

**Note**  
 The above exploded view is for the purpose of parts disassembly and replacement.  
 The non-numbered parts are not kept as standard service parts.

SAFETY	REF. NO.	PART NAME & DESCRIPTION	QTY.	CU-Z71YKEA	REMARK
	1	CHASSIS COMPLETE	1	ACXD52K01770	
	2	FAN MOTOR BRACKET	1	ACXD54-00140	
	3	SCREW - FAN MOTOR BRACKET	2	ACXH55-07140	
⚠	4	FAN MOTOR	1	L6CAYYYL0169	O
	5	SCREW - FAN MOTOR MOUNT	4	CWH551106J	
	6	PROPELLER FAN ASSY	1	ACXH03K00070	
	7	NUT - PROPELLER FAN	1	CWH56053J	
	8	ANTI - VIBRATION BUSHING	3	CWH50077	
⚠	10	COMPRESSOR	1	9RD220XBA21	O
	11	NUT - COMPRESSOR MOUNT	3	CWH561096	
	12	CONDENSER	1	ACXB32C22970	
	13	TUBE ASSY (CAPILLARY TUBE)	1	ACXT00C20450	
	14	HOLDER COUPLING	1	ACXH35-00080	
	15	4-WAYS VALVE	1	ACXB00-00140	
	16	DISCHARGE MUFFLER (4-WAY VALVE)	1	CWB121013	
	17	RECEIVER	1	CWB14030	
	18	2-WAYS VALVE (LIQUID)	1	ACXB02-03230	
	19	3-WAY VALVE (GAS)	1	CWB011363	
	20	TERMINAL COVER	1	CWH171039A	
	21	NUT - TERMINAL COVER	1	CWH7080300J	
	22	SOUND PROOF BOARD	1	ACXH15-00230	
	23	SOUND PROOF MATERIAL - COMP. BODY	1	ACXG30-11560	
	24	SOUND PROOF MATERIAL - COMP. TOP	1	CWG302314	
	26	SOUND PROOF MATERIAL - SOUND PROOF BOARD	1	CWG302985	
⚠	27	SENSOR CO-COMP TEMP	1	ACXA50C17400	O
	28	CONTROL BOARD COVER-TOP	1	ACXH13-00490	
⚠	29	ELECTRONIC CONTROLLER - MAIN	1	ACXA73C83720R	O
⚠	30	TERMINAL BOARD ASSY	1	CWA28K1036J	O
	31	CABINET SIDE PLATE CO.	1	ACXE04C00700	
⚠	32	SENSOR CO-AIR TEMP AND PIPE TEMP	1	CWA50C3079	O
	33	HANDLE	1	CWE161010	
	34	CABINET SIDE PLATE	1	ACXE04-00580	
	35	CABINET FRONT PLATE CO.	1	ACXE06K02020	
	36	CABINET TOP PLATE	1	ACXE03-00200	
	37	PLATE - C. B. COVER TERMINAL	1	CWH131470	
	38	CONTROL BOARD COVER CO.	1	ACXH13C00170	
	39	STRAINER	1	CWB111032	
⚠	40	REACTOR	1	G0C392J00040	O
	41	EXPANSION VALVE	1	ACXB05-01070	
⚠	42	V-COIL COMPLETE - 4-WAY VALVE	1	ACXA43C00250	O
⚠	43	V-COIL COMPLETE - EXP. VALVE	1	ACXA43C06110	O
	44	ACCESSORY-COMPLETE	1	ACXH82C21740	
	47	OPERATING INSTRUCTION	1	ACXF55-32680	
	48	OPERATING INSTRUCTION	1	ACXF55-32690	
	49	OPERATING INSTRUCTION	1	ACXF55-33180	
	50	OPERATING INSTRUCTION	1	ACXF55-32700	
	51	OPERATING INSTRUCTION	1	ACXF55-32710	

SAFETY	REF. NO.	PART NAME & DESCRIPTION	QTY.	CU-Z71YKEA	REMARK
	52	OPERATING INSTRUCTION	1	ACXF55-30282	
	53	OPERATING INSTRUCTION	1	ACXF55-30292	
	54	OPERATING INSTRUCTION	1	ACXF55-30302	
	55	OPERATING INSTRUCTION	1	ACXF55-28413	
	56	INSTALLATION INSTRUCTION	1	ACXF60-45640	
	57	INSTALLATION INSTRUCTION	1	ACXF60-45650	
	58	INSTALLATION INSTRUCTION	1	ACXF60-45660	
	59	INSTALLATION INSTRUCTION	1	ACXF60-45670	
	60	INSTALLATION INSTRUCTION	1	ACXF60-45680	
	61	INSTALLATION INSTRUCTION	1	ACXF60-45690	
	62	INSTALLATION INSTRUCTION	1	ACXF60-45700	
	63	INSTALLATION INSTRUCTION	1	ACXF60-45710	
	64	INSTALLATION INSTRUCTION	1	ACXF60-45720	
	65	INSTALLATION INSTRUCTION	1	ACXF60-45730	
	66	INSTALLATION INSTRUCTION	1	ACXF60-45740	
	67	INSTALLATION INSTRUCTION	1	ACXF60-45750	
	68	INSTALLATION INSTRUCTION	1	ACXF60-45760	
	69	INSTALLATION INSTRUCTION	1	ACXF60-45770	
	70	INSTALLATION INSTRUCTION	1	ACXF60-45780	
	71	ACCUMULATOR	1	ACXB13-00010	
	72	BADGE	1	CWE373439	
	73	WIRE NET	1	ACXD04-00130A	
	74	BAG	1	ACXG86-05720	
	75	BASE BOARD-COMplete	1	ACXG62C02440	
	76	SHOCK ABSORBER - TOP LEFT	1	ACXG70-14460A	
	77	SHOCK ABSORBER - TOP RIGHT	1	ACXG70-14470A	
	78	C.C.CASE	1	ACXG50-48882	
	79	MODEL LABEL	2	ACXF85-85710	

(NOTE)

- All parts are supplied from PAPAMY, Malaysia (Vendor Code: 00029488).
- "O" marked parts are recommended to be kept in stock.